

All electrical wiring to be performed by a licensed electrician in accordance with NEC or the local electrical code

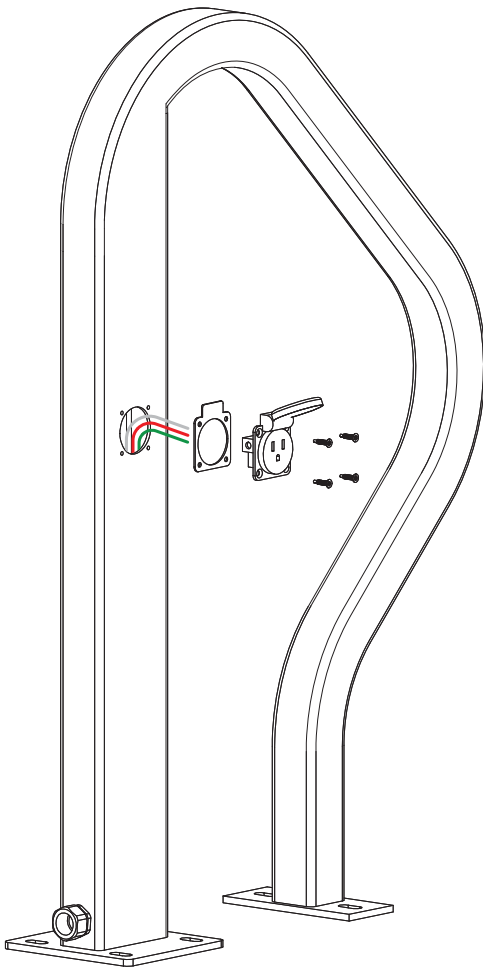

- 1** Route electrical wires through the bike rack and receptacle gasket.
- 2** Connect electrical wires to receptacle
- 3** Fasten the receptacle and gasket to the bike rack with (4) self-drilling screws
- 4** Repeat for second receptacle
- 5** Attach ground wires with #10 ring lug to bike rack ground ground with a #10-24 screw + tooth washer
- 6** Connect power and neutral wires to GCFI circuit breaker 125V/15A max

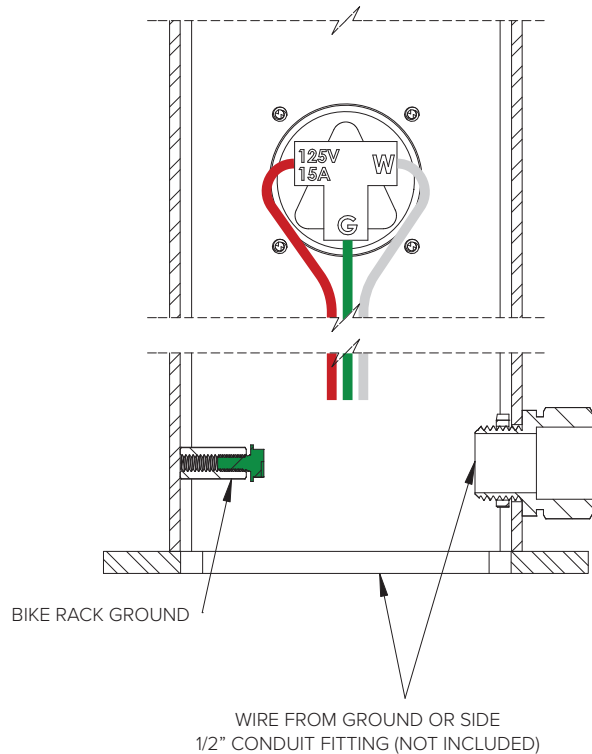



TOOLS NEEDED

- Tape Measure
- Marker or Pencil
- Masonry Drill Bit
- Drill (Hammer drill recommended)
- Hammer
- Wrench 9/16"
- Level
- Washers (for leveling if necessary)

RECOMMENDED BASE MATERIAL

Solid concrete is the best base material for installation. To ensure the proper anchors are shipped with your rack, ask your Dero Rack representative which anchor is appropriate for your application. Be sure nothing is underneath the base material that could be damaged by drilling.

1

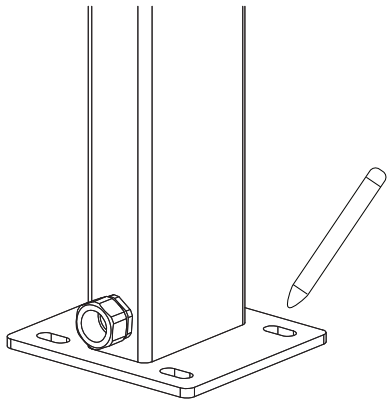

Place the rack in the desired location. Use a marker or pencil to outline the holes of the flange onto the base material.

2

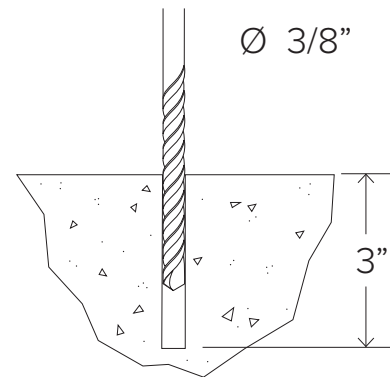

Drill 3/8" diameter holes 3" deep into surface. Make sure the holes are at least 3" away from any cracks in the base material.

3

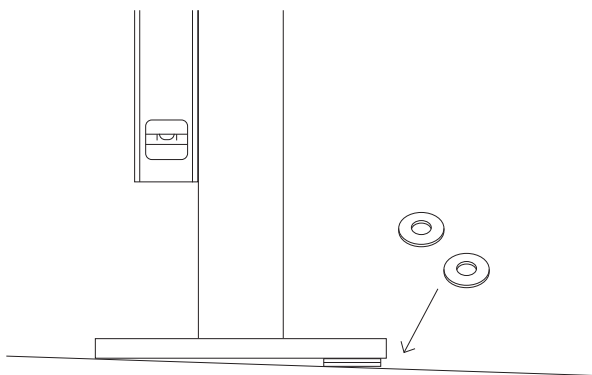

Place rack (and washers to level rack if necessary) over holes.

4

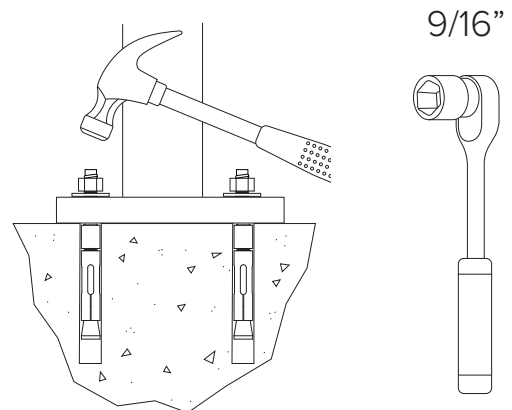

Thread nuts onto anchors, leaving approximately 1/4" of the anchor protruding, and tap into surface. Tighten nuts down to secure rack.