

# INSTALLATION INSTRUCTIONS FOR FOUNTAIN

Prepare wall for mounting drinking fountain. Make certain that mounting bolts are long enough to pass through front and back mounting plates and wall. Obtain longer bolts if necessary.

Note hole pattern shown in illustration. After marking bolt pattern on wall, place front mounting plate in position to ensure that bottom of arm is 27 inches above grade.

Adjust hole pattern as necessary. Drill mounting holes through wall as shown.

Carefully position drinking fountain against wall, aligning hole pattern in front mounting plate with hole pattern in wall. Guide supply and drain lines through corresponding holes in wall.

Support fountain as necessary to complete installation. Insert mounting bolts through front mounting plate and wall. On opposite side of wall, place back mounting plate over bolts and secure with nuts.

Check to be certain that arm is 27 inches above grade. Use bubble level to ensure that bowl is level in both directions. Adjust as necessary and then tighten nuts. Bolt threads may be deformed slightly on rear for security of drinking fountain.

Connect supply and drain lines to drinking fountain as necessary. Turn on water supply and verify that unit operates properly.

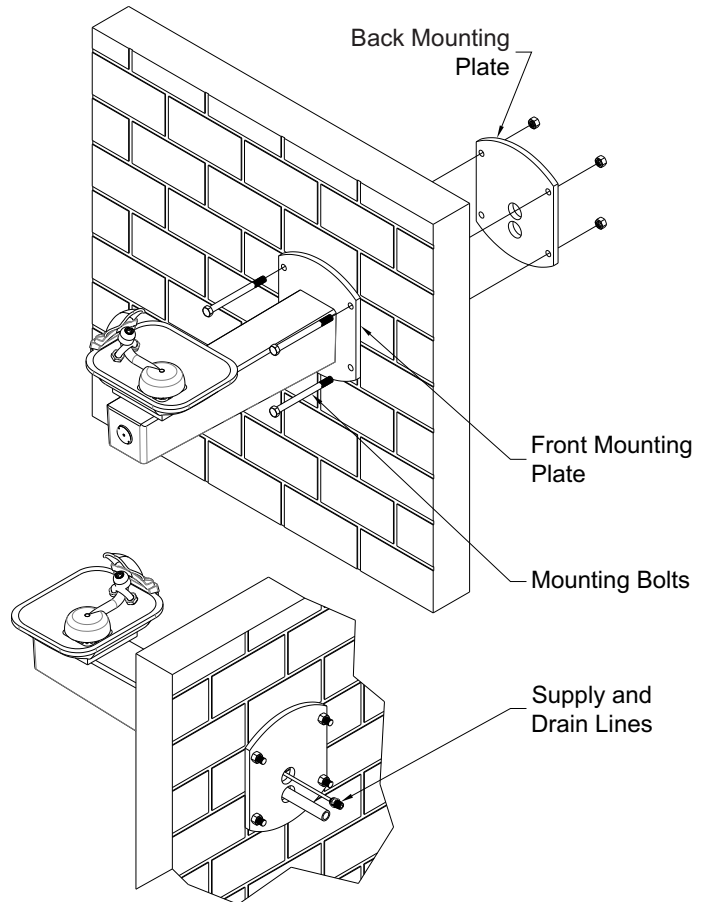

# MAINTENANCE INSTRUCTIONS

To remove pushbutton assembly, shut-off water supply inside arm, remove inlet and outlet lines from quick-disconnect ports of valve body. With provided Allen key wrench, unscrew pushbutton. Back out the retaining nut from flange collar as necessary to allow the brass retaining nut to be removed from the front of the unit.

To replace the cartridge, unscrew retaining nut from valve body by utilizing the spanner key that was provided. Align ports of new cartridge with mating ports in valve body and replace retaining nut.

To re-install pushbutton assembly, insert valve body back into pushbutton slot located on fixture. With flange collar visible, secure Brass Retaining Ring enough to allow pushbutton to be flush with unit. Once Brass Retaining Ring is located properly, tighten retaining ring located inside the unit to keep valve body in place. Secure pushbutton to flange collar enough to prevent removal of pushbutton, but not tight enough to impede pushbutton activation.

