

# BARRIER FREE, WALL MOUNTED, ANGLED, BI-LEVEL DRINKING FOUNTAIN

## STANDARD FEATURES

- Both Child or Adult ADA Compliant (when properly installed)
- Optionally Available with “Hands Free” Controls
- 18 Gauge, 304 Stainless Steel Bowls
- 12 Gauge, Heavy Duty Stainless Steel Arm, Corrosion and Scratch Resistant Finish
- Heavy Duty Stainless Steel, Vandal Resistant Bottom Access Panels
- 1/4” Thick Stainless Steel Mounting Plate
- Pushbutton With Cartridge Valve Assembly
- Polished Stainless Steel, Anti-Rotation, Non-Squirt Bubbler
- Resistant to Sunlight, Heat, Moisture and Wear
- 100-Mesh Inlet Strainer

## SUGGESTED SPECIFICATIONS

Wall Mounted Round Bi-Level Drinking Fountain shall be Murdock model GRE24. Drinking Fountain shall be 18 gauge, type 304 stainless steel bowls with a 12 gage, heavy duty stainless steel support arm. Provide 1/4” thick stainless steel mounting plate to securely anchor unit to wall. Access Panels shall be secured with vandal-resistant stainless steel screws. Unit shall be activated by a front mounted, self-closing Pushbutton with Cartridge Valve Assembly, using less than 5 pounds of force to activate with an adjustable stream regulator controlling the water flow. Bubbler shall be polished stainless steel with a Non-Squirt feature and operate on water pressure range of 20-105 PSIG. P-Trap shall be installer provided behind wall (Optional -PT P-Trap with access below fixture is available). Fountain to be compliant to ANSI A117.1, Public Law 111-380 (NO-LEAD), CHSC 116875 and NSF/ANSI 61, Section 9. Fixture to meet ADA, ADA Standing Person, and ADA Child requirements when mounted appropriately.

Option Notes:

<sup>1</sup>See separate option sheet

Complies with the following standards:



NSF/ANSI 61



Federal Public Law 111-380 (No Lead)



Model: GRE27-R Shown

“FOR INDOOR AND OUTDOOR USE”

## MODEL:

(Must Specify)

- Satin Stainless Finish
- Green Powder-Coated
- Red Powder-Coated
- Blue Powder-Coated (Shown)

Custom color finishes available upon request

## ADA DRINKING FOUNTAIN ORIENTATION

(Must Specify)

- L ADA Drinking Fountain Left Side (Opposite)
- R ADA Drinking Fountain Right Side (Shown)

## OPTIONS

(additional costs may be incurred)

- FRA2 Freeze Resistant Valve, Two Valves<sup>1</sup>
- LOGO Customer specified logo
- PT 1-1/4” OD P-Trap (Access Below Fixture)
- SOC Concealed Sensor Operation Drinking Fountains - Battery Operated Standard (N/A with -FRA2<sup>1</sup>)
- 316 Type 316 Stainless Steel Construction



Member of U.S. Green Building Council



Recyclable Product



Water Conserving Product

⚠ WARNING: Cancer and Reproductive Harm - [www.P65Warnings.ca.gov](http://www.P65Warnings.ca.gov)

\* Valve specifications:  
Minimum/Maximum  
Pressure 30 to 100 psi.

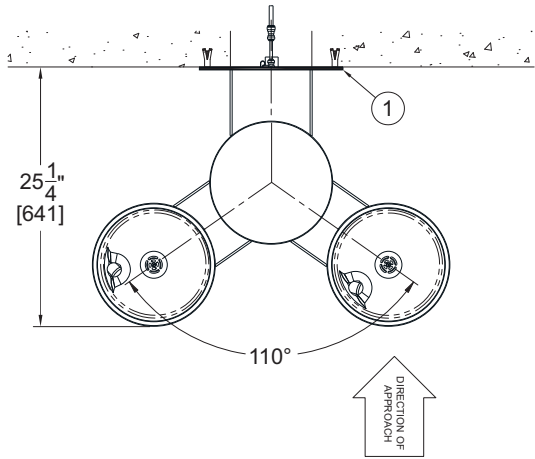

## BARRIER FREE, WALL MOUNTED ANGLED BI-LEVEL DRINKING FOUNTAIN

### NOTES:

1. 1/4" THICK SS MOUNTING PLATE
2. REMOVABLE ACCESS PANELS
3. DRINKING BUBBLER
4. PUSHBUTTON WITH CARTRIDGE VALVE ASSEMBLY
5. 1-1/4" O.D. WASTE OUTLET FOR P-TRAP BEHIND WALL (STANDARD) P-TRAP PROVIDED BY OTHERS
6. 3/8" O.D. SUPPLY CONNECTION
7. INSTALLER PROVIDED WALL ANCHORS AND ANCHORING HARDWARE

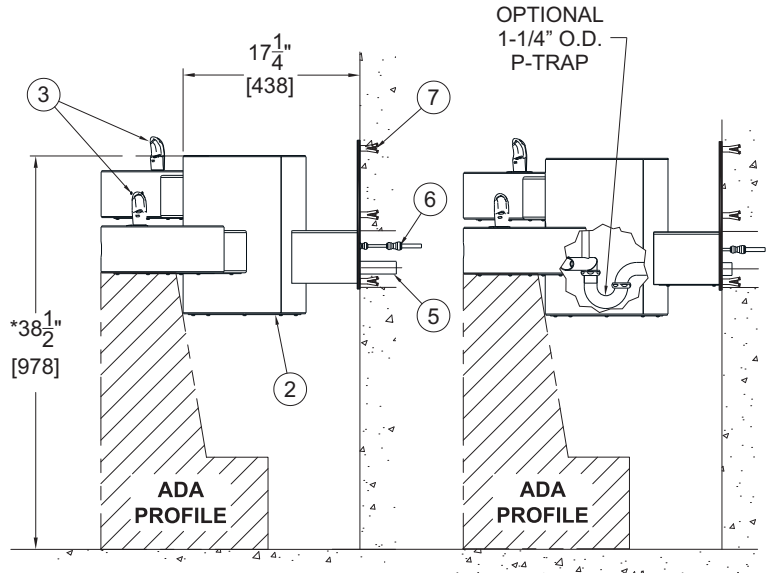
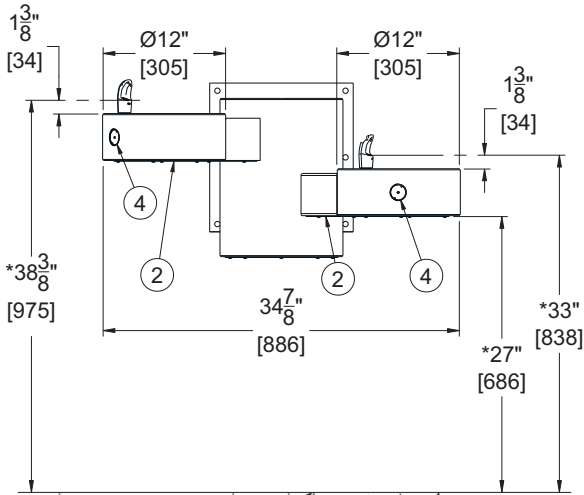

### GRE24-R SHOWN

### GENERAL NOTES:

1. ALL DIMENSIONS ARE IN INCHES [MM].
- \*2. DIMENSIONS SHOWN ARE FOR RECOMMENDED ADULT HEIGHT. ADJUST VERTICAL DIMENSIONS AS NECESSARY TO COMPLY WITH FEDERAL, STATE, & LOCAL CODES.
3. STOP VALVE NOT PROVIDED.

**IMPORTANT:** Refer to installation instructions for complete rough-in and technical data.  
**NOTE:** Some options may change standard roughs.