

NO.	PART NUMBER	DESCRIPTION	MATERIAL	QTY.
1	AFG-SA4	AFG FINAL GRILL ASSEMBLY		1
2	IFP-SAS	ANCHOR SPADE WELD ASSEMBLY		3
3	HBOLT 0.5000-13x1.5x1.25-N	1/2"-13x 1 1/2" HEX BOLT		3
4	Regular LW 0.5	1/2" REGULAR LOCK WASHER		3
5	HNUT 0.5000-13-D-N	1/2"-13 HEX LOCKNUT		3

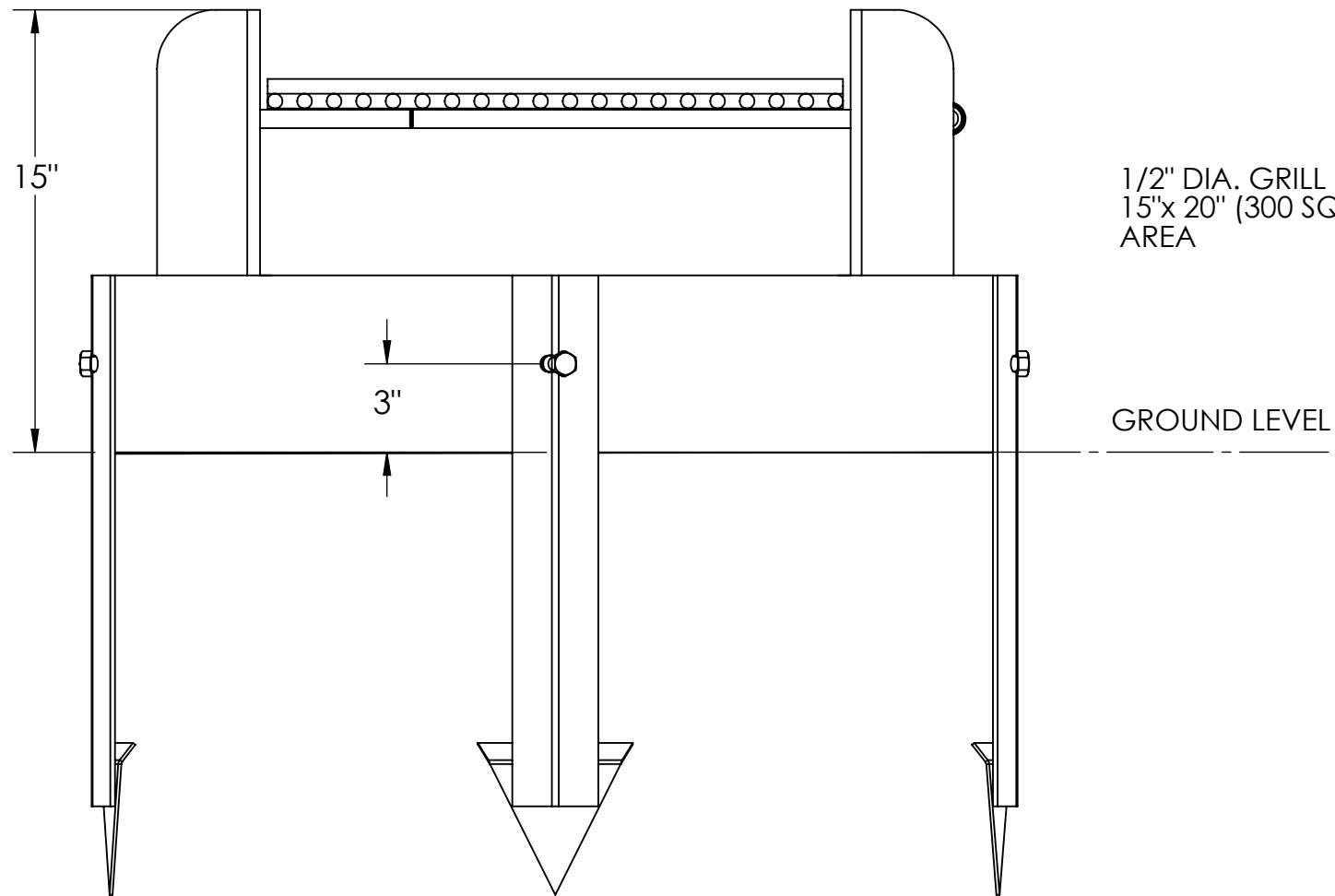

3/16" STEEL GRATE SUPPORT AND HEAT SHIELD PANELS THIS ALLOWS (4) LEVELS OF GRATE ADJUSTMENTS

1/2" DIA. GRILL RODS
15"x 20" (300 SQIN. GRILL AREA)

GROUND LEVEL

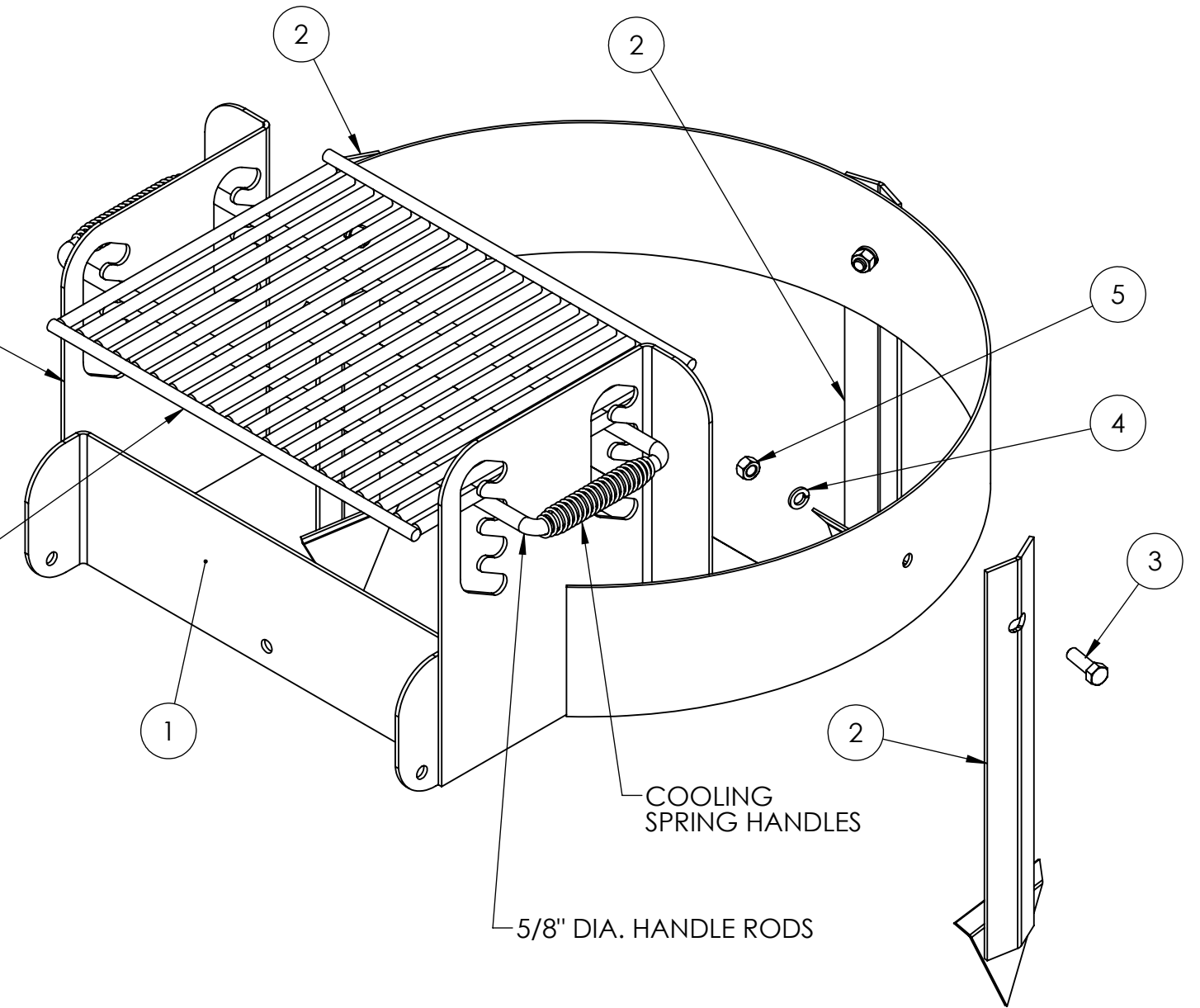

1. Before the assembly mark line on the ground the out side the grill for anchor spade placement and at as same time mark the center line where is bolts mount to grill.
2. Then take a hammer and insert the spade anchor into ground from outside line. Repeat this step with other spade anchors.
3. Place (3) 1/2" x 1 1/2" Hex Bolts into the hole of the Spade anchor and through the hole of base grill and other side use lock washer and nuts.

UNIT WGT: 81.35 Lbs.

GENERAL NOTES	DIMENSIONS ARE IN INCHES TOLERANCES: LINEAR: ± 1/16 ANGULAR: ± 1°	SHEET SIZE B	SCALE 1:6	REV	
	CONFIDENTIAL DRAWING. INFORMATION IS NOT TO BE COPIED OR DISCLOSED TO OTHERS WITHOUT CONSENT OF KAY INDUSTRIES. SPECIFICATIONS SUBJECT TO CHANGE WITHOUT NOTICE.	DRAWN BY	JNB	7/11/2017	DESC: FIRE RING W/ADJUSTABLE GRATE & SPADE ANCHORS
		APPROVED			MATL:
		LAST SAVED	johnb	8/1/2017	PART NO: AFG80SAS