

Square Concrete Pedestal Mount Outdoor Drinking Fountain-Bi Level

STANDARD FEATURES

- Adult ADA Compliant
- Resistant to sunlight, heat, moisture and wear
- 18 gage, 304 stainless steel bowl
- Reinforced concrete with aggregate finish
- Polished stainless steel, anti-rotation non-squirt bubbler
- 100 mesh inlet strainer
- Access door, heavy duty steel, vandal resistant
- Vandal resistant galvanized steel bottom plate

SUGGESTED SPECIFICATIONS

Model GVM49 is a barrier free pedestal mounted, vandal resistant, bi-level square drinking fountain made from 18 gage, 304 stainless steel bowls mounted into a reinforced brown concrete aggregate pedestal. Unit shall be activated by front mounted self-closing buttons, by using less than 5 pounds of force, which activates internally mounted valves with adjustable stream regulators controlling the water flow. Bubblers shall be polished stainless steel with non-squirt features and operate on water pressure range of 20-105 psig. Fountain is certified to ANSI A117.1, Public Law 111-380 (NO-LEAD), CHSC 116875 and NSF/ANSI 61, Section 9. Fixture meets ADA, ADA Standing Person, and ADA Child requirements when mounted appropriately.

Options Notes:

¹ See separate option sheet.

² This option is not available freeze-resistant.



MODEL:

(Must Specify)

Tan Concrete Aggregate

Brown Concrete Aggregate (Shown)

OPTIONS

(additional costs may be incurred)

- CH30 Child height, 30" bubbler height
- FRU2 Freeze resistant, 2 valves ¹
- FRU3 Freeze resistant, 3 valves ¹
- FRU4 Freeze resistant, 4 valves ¹
- FS Foot spray
- HB1 Hose bibb, compression, with hose threaded outlet/VB ^{1 2}
- HB2 Hose bibb, loose key, with hose threaded outlet/VB ^{1 2}
- HB4 Hose bibb, loose key, recessed vandal resistant, with hose threaded outlet/VB ^{1 2}
- IGM In-ground 14" mounting
- JF1 Jug filler, spigot, self-closing valve with plain end ^{1 2}
- JF2 Jug filler, pushbutton, self-closing valve with plain end ¹
- NP2 Non-pollutable, freeze resistant, 2 valves
- NP3 Non-pollutable, freeze resistant, 3 valves
- NP4 Non-pollutable, freeze resistant, 4 valves
- PF Pet fountain
- SCS Square concrete step for pedestal fountain

Complies with the following standards:



Member of
U.S. Green
Building
Council



Recyclable
Product



Water
Conserving
Product

 WARNING: Cancer and Reproductive Harm - www.P65Warnings.ca.gov

IMPORTANT: INSTALLATION AND SITE PREP FOR FREEZE RESISTANT OPTIONS "-FRU, -NP" WILL DIFFER FROM STANDARD. REFER TO DESIGNATED FREEZE RESISTANT INSTALLATION DETAILS.

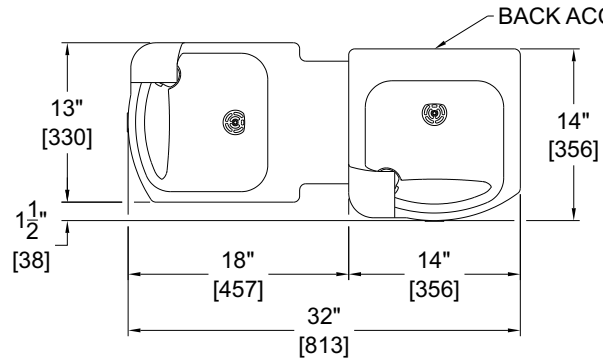

**BARRIER FREE, BI-LEVEL,
PEDESTAL MOUNTED
DRINKING FOUNTAIN**

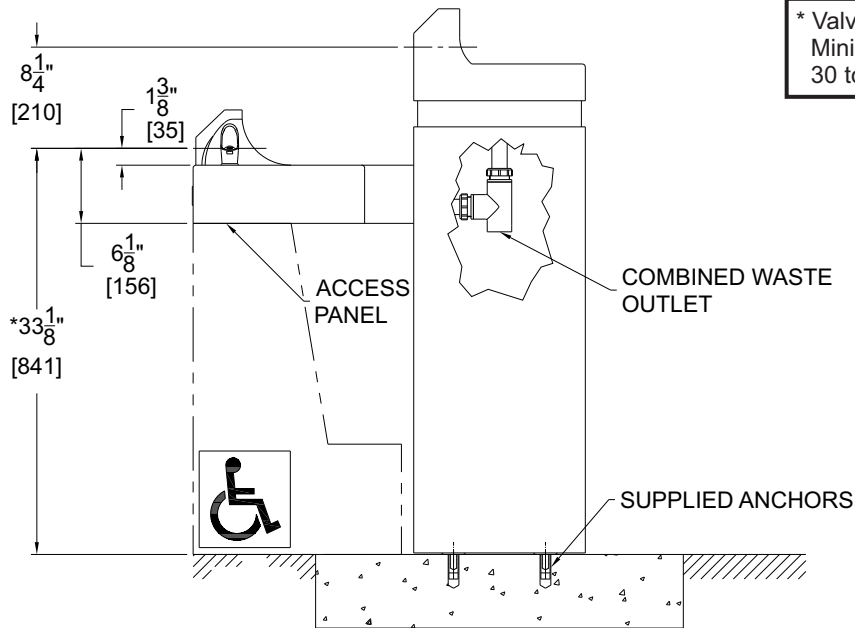

* Valve specifications:
Minimum/Maximum Pressure
30 to 100 psi.

GENERAL NOTES:

1. ALL DIMENSIONS ARE IN INCHES [MM].
- *2. STANDARD ADULT ADA HEIGHT MODEL SHOWN. OPTIONAL -CH30 CHILD ADA HEIGHT MODEL AVAILABLE.
3. STOP VALVE NOT PROVIDED.