

RECESSED OUTDOOR BOTTLE FILLER WITH GRC DRINKING FOUNTAIN

STANDARD FEATURES

- 115v Plug-in transformer
- Pushbutton and hands free sensor operated bottle filler
- 100 mesh inlet strainer
- Laminar Flow Water Supply
- 1.0 GPM Fill Rate
- Lead-free
- Lead and cyst filter for bottle filler
- Bottle filler meets ADA forward side and reach requirements
- Vandal-resistant design
- Gasketed door for weather resistance
- ADA Complaint (when properly installed)
- Resistant to sunlight, heat, moisture and wear
- 18 gage, 304 stainless steel bowl
- 12 gage, heavy duty stainless steel arm, corrosion and scratch resistant
- Polished Stainless steel, anti-rotation non-squirt bubbler

SUGGESTED SPECIFICATIONS

Model M-OBR4-GRC is a recessed outdoor bottle filler. Housing has a slim and trim look that blends into your environment. Unit also has a strong vandal-resistant design for years of trouble-free service. Bottle filler shall be activated by a 9 volt sensor or a pushbutton as standard. Fixture has a self-closing pushbutton, needing less than 5 pounds of force which shall activate the internally mounted valve. When installed properly, the bottle filler complies with ADA forward and side reach requirements. Bottle filler is fabricated of type 304 stainless steel. Unit includes GRC series barrier free drinking fountain. Bottle filler cabinets and drinking fountain shall be either stainless steel with powder coat or satin finish. Unit complies with ANSI A117.1, Public Law 111-380 (NO-LEAD), CHSC 116875 and NSF/ANSI 61, Section 9. Fixture meets ADA requirements when mounted appropriately.



MODEL:

(Must Specify)

Satin stainless finish (Shown)

Green powder-coated

Red powder-coated

Blue powder-coated

Custom color finishes available upon request

OPTIONS

(additional costs may be incurred)

- BAT Battery operated (N/A with bottle counter)
- BCD Bottle counter display
- FRA2 Freeze-resistant valve system, 2 valves (Less filter and sensor)
- LOGO Customer specified logo
- MO Bottle filler operated by pushbutton only (Standard with freeze-resistant valve)
- A9100080-A 8 GPH remote water chiller (Located on interior wall, not exposed to weather)

Complies with the following standards:



Member of
U.S. Green
Building
Council



Recyclable
Product



Water
Conserving
Product

⚠ WARNING: Cancer and Reproductive Harm - www.P65Warnings.ca.gov

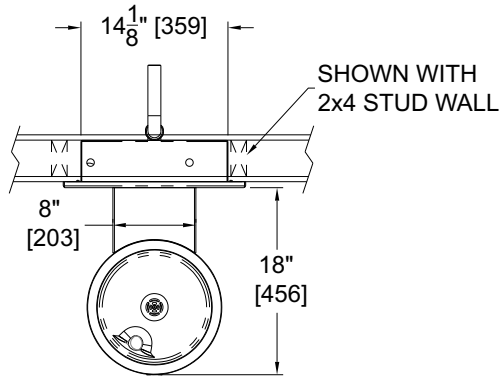

RECESSED OUTDOOR BOTTLE FILLER WITH GRC DRINKING FOUNTAIN

GENERAL NOTES:

1. ALL DIMENSIONS ARE IN INCHES [MM]
- *2. DIMENSIONS SHOWN ARE FOR RECOMMENDED ADULT HEIGHT. ADJUST VERTICAL DIMENSIONS AS NECESSARY TO COMPLY WITH FEDERAL, STATE & LOCAL CODES
3. STOP VALVE NOT PROVIDED

