

PEDESTAL MOUNTED BOTTLE FILLER WITH DRINKING FOUNTAIN

STANDARD FEATURES

- Adult ADA compliant for wheelchair users
- Pushbutton and hands free sensor operated Bottle filler
- Battery pack 6-AA
- Laminar flow water supply to bottle filler
- Resistant to sunlight, heat, moisture and wear
- 18 Gage, 304 stainless steel drinking Fountain bowls
- 12 Gage, heavy duty stainless steel construction with corrosion and scratch resistant finish
- Stainless steel, anti-rotation non-squirt bubbler
- Lead and cyst filter (Not available with FRU option)
- 100 mesh inlet strainer
- Access cover, heavy duty stainless steel, vandal resistant

SUGGESTED SPECIFICATIONS

Pedestal bottle filler with drinking fountain shall be Murdock model GYM74. Construction shall be 12 gage, all stainless steel with 18 gage stainless steel fountain bowl. Pedestal base shall have four mounting holes. Access covers shall be secured with vandal-resistant stainless steel screws. Bottle filler shall be activated by a 9 volt sensor or a pushbutton as standard and provide 1.0 GPM flow. Unit shall contain a 100 mesh inlet strainer, lead and cyst filter, 6-AA battery pack and laminar flow spout. Self-closing pushbutton, needing less than 5 pounds force, shall activate internally mounted valve with adjustable stream regulator. Bubbler shall be stainless steel with non-squirt feature and operate on water pressure range of 20-105 psig. Fountain is certified to ANSI A117.1, Public Law 111-380 (NO-LEAD), CHSC 116875 and NSF/ANSI 61, Section 9. Fixture meets ADA requirements when mounted appropriately.

Options Notes:

¹ See separate option sheet.

² This option is not available freeze-resistant.



Model GYM75-PF Shown

MODEL:

(Must Specify)

- Satin Stainless Finish
- Green Powder-Coated (Shown)
- Red Powder-Coated
- Blue Powder-Coated

OPTIONS

(additional costs may be incurred)

- CH30 Child height, 30" bubbler height
- CV Cartridge valve on fountain ^{1 2}
- FRU2 Freeze resistant, 2 valves ¹ (Less Filter and sensor)
- FRU3 Freeze resistant, 3 valves ¹ (Less Filter and sensor)
- FRU4 Freeze resistant, 4 valves ¹ (Less Filter and sensor)
- FS Foot shower
- HB1 Hose bibb, compression, with hose threaded outlet/VB ^{1 2}
- HB3 Hose bibb, loose key, vandal resistant, locked door with hose threaded outlet/VB ^{1 2}
- IAP In-ground anchor plate
- IGM In-ground 14" mounting adapter
- JF1 Jug filler, spigot, self-closing valve with plain end ^{1 2}
- JF2 Jug filler, pushbutton, self-closing valve w/ plain end ¹
- JFFR1 Jug filler, pushbutton, freeze resistant, self closing valve ¹
- MO Bottle filler operated by pushbutton only (Standard with freeze-resistant valves)
- NP2 Non-pollutable, freeze resistant, 2 valves
- NP3 Non-pollutable, freeze resistant, 3 valves
- PF Pet fountain receptor ¹

Complies with the following standards:



Member of U.S. Green Building Council



Recyclable Product



Water Conserving Product

⚠ WARNING: Cancer and Reproductive Harm - www.P65Warnings.ca.gov

IMPORTANT: INSTALLATION AND SITE PREP FOR FREEZE RESISTANT OPTIONS "-FRU, -NP" WILL DIFFER FROM STANDARD. REFER TO DESIGNATED FREEZE RESISTANT INSTALLATION DETAILS.

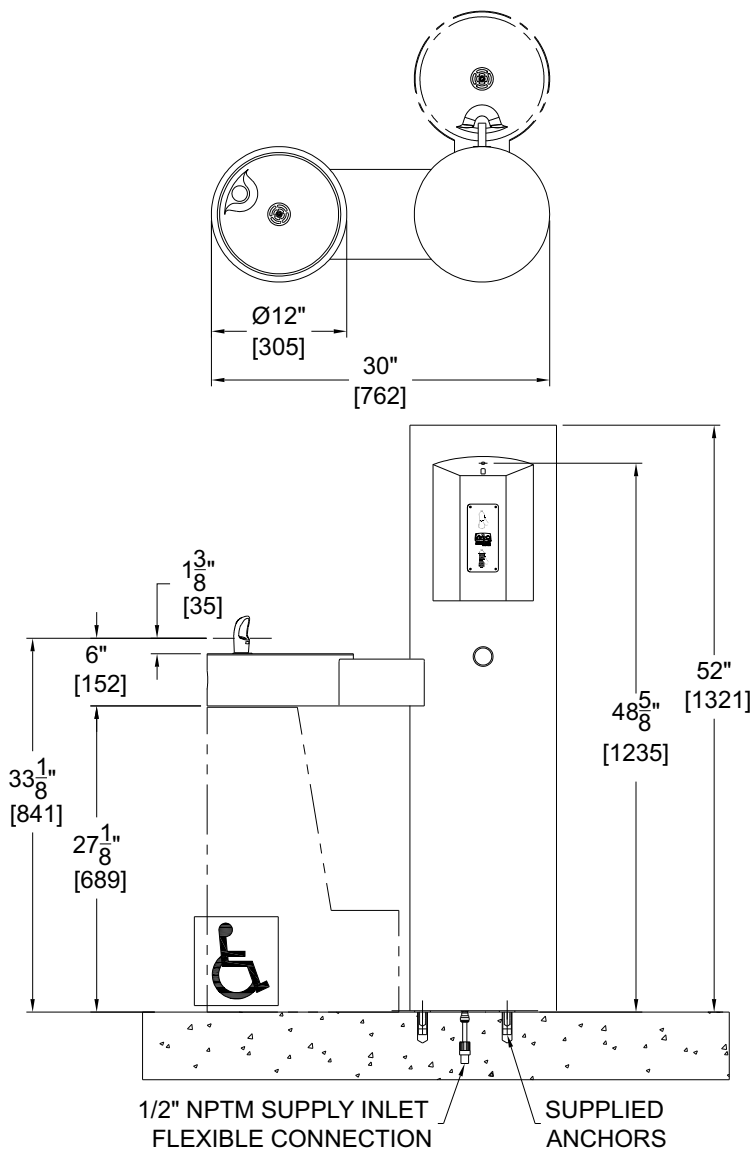

**PEDESTAL MOUNTED
BOTTLE FILLER
WITH DRINKING FOUNTAIN**

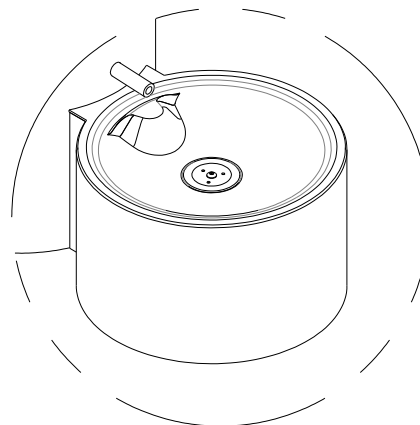

**OPTIONAL -PF
PET FOUNTAIN
DETAIL**

- GENERAL NOTES:
1. ALL DIMENSIONS ARE IN INCHES [MM]
 2. STOP VALVE NOT PROVIDED

* Valve specifications:
Minimum/Maximum Pressure
30 to 100 psi.