

Economy Pedestal Drinking Fountain

PEDESTAL MOUNTED DRINKING FOUNTAIN

STANDARD FEATURES

- Resistant to sunlight, heat, moisture and wear
- 18 gage, 304 stainless steel bowl
- Heavy 1-1/4" IPS steel pipe, powder coated
- Polished stainless steel, anti-rotation non-squirt bubbler with valve and lever handle



SUGGESTED SPECIFICATIONS

Model GWF55 is a pedestal mounted, round drinking fountain made from 18 gage, 304 stainless steel. Basin shall be mounted onto a green powder coated heavy duty steel pipe pedestal. Unit shall be activated by a self-closing lever operated valve unless a pushbutton bubbler option is selected. Bubbler shall be polished stainless steel with a non-squirt feature and operate on a water pressure range of 20-105 psig. Unit is certified to ANSI A117.1, NSF/ANSI 61, Section 9, Public Law 111-380 (No-Lead) and CHSC 116875.

MODEL:

(Must Specify)

LEAD-FREE STAINLESS STEEL w/ VALVE & LEVER HANDLE

- Green powder-coated (Shown)
- Red powder-coated
- Blue powder-coated

LEAD-FREE STAINLESS STEEL PUSHBUTTON BUBBLER

- GWF65 Green powder-coated
- GWF66 Red powder-coated
- GWF67 Blue powder-coated

Custom color finishes available upon request

OPTIONS

(additional costs may be incurred)

- CH30 Child height, 30" Bubbler height

Complies with the following standards:



Member of U.S. Green Building Council



Recyclable Product



Water Conserving Product

WARNING: Cancer and Reproductive Harm - www.P65Warnings.ca.gov

PEDESTAL MOUNTED DRINKING FOUNTAIN

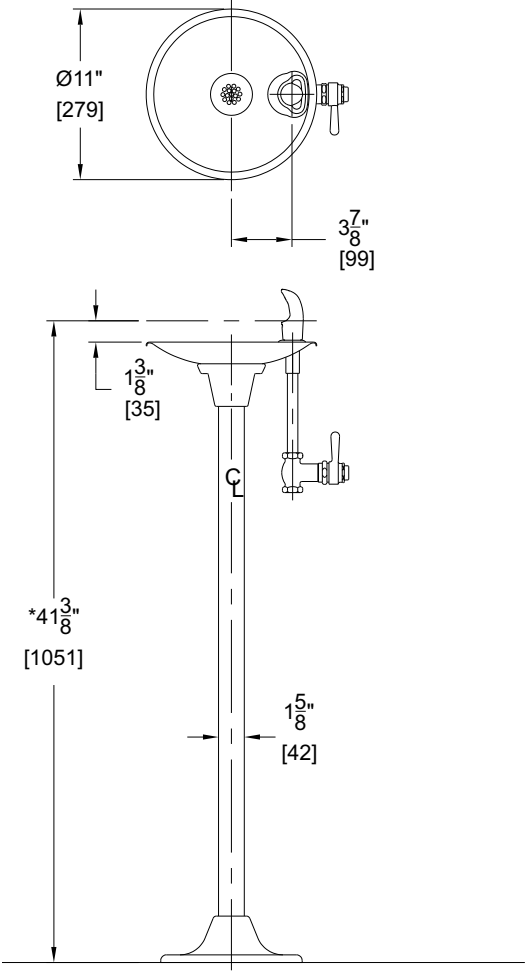

GENERAL NOTES:

- 1. ALL DIMENSIONS ARE IN INCHES [MM].
- *2. STANDARD ADULT HEIGHT MODEL SHOWN. OPTIONAL -CH30 CHILD HEIGHT MODEL AVAILABLE.
- 3. STOP VALVE AND UNION NOT PROVIDED.