

Architectural Series

DRINKING FOUNTAIN WITH BOWL ON PEDESTAL

STANDARD FEATURES

Architectural Style Pedestal Mount Outdoor Drinking Fountain features design simplicity. This single fountain unit includes a pedestal mounted bowl and stainless steel bubbler operated by separate pushbutton control. Standard model is seasonal, not freeze resistant. Heavy duty construction ensures durability. Field serviceable components are easily accessible. Solid brass casting for bowl is *Penny Vein* powder coated and base/arm is finished in *Chestnut Brown*.

SUGGESTED SPECIFICATIONS

Drinking fountain shall be Murdock model M-43C. Unit shall be furnished with a pedestal mounted bowl.

Pedestal shall be heavy duty iron casting and base of pedestal shall have four mounting holes. Pedestal shall be furnished with a heavy grade of oil based enamel.

Bowl shall be octagonal, powder coated, solid brass casting. Pet Fountain options provide a cast aluminum bowl with matte finish.

Valve shall be self-closing, pushbutton operated, incorporating a replaceable cartridge and requiring less than 5 pounds of force to operate. Valve shall include an adjustable stream regulator controlling the water.

Bubbler shall be stainless steel and operate on a water pressure range of 30 - 105 psig.

All solid brass castings shall conform to ASTM standards B61 and B62. Unit is certified to Public Law 111-380 (NO-LEAD), CHSC 116875 and NSF/ANSI 61, Section 9.



OPTIONS

(additional costs may be incurred)

- Added arm and bowl with bubbler at 30" disabled child height ¹
- Underground freeze-resistant valve for one bowl ¹
- Underground freeze-resistant valve for two bowls
- Hose bibb with vacuum breaker ^{1 2}
- Jug filler with self-closing spigot valve ^{1 2}
- Jug filler with pushbutton valve ¹
- Pet fountain with pushbutton valve ¹
- Pet fountain with self-closing spigot valve ^{1 2}
- Chrome plated cast brass drinking fountain bowl
- **Black** Pedestal color black
- **Green** Pedestal color green

Options Notes:

¹ See separate option sheet.

² This option is not available freeze-resistant.

Custom color finishes available upon request.

Complies with the following standards:



Member of
U.S. Green
Building
Council



Recyclable
Product



Water
Conserving
Product

 WARNING: Cancer and Reproductive Harm - www.P65Warnings.ca.gov

Architectural Series

DRINKING FOUNTAIN WITH BOWL ON PEDESTAL

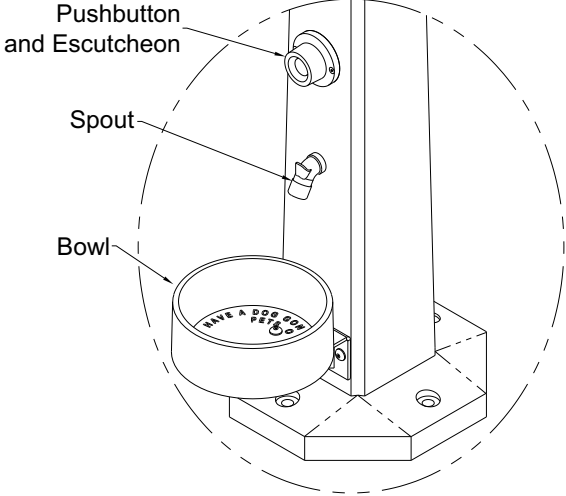
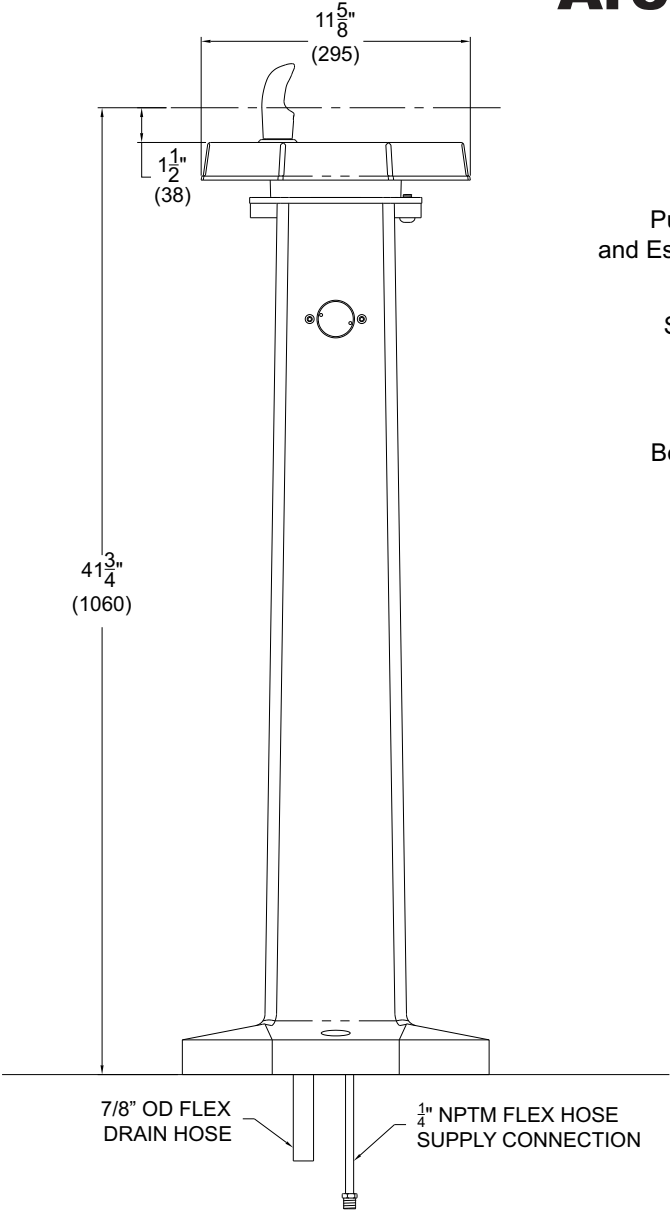

OPTIONAL -PF PET FOUNTAIN

* Valve specifications:
Minimum/Maximum Pressure
30 to 100 psi.