

Round Pedestal Mount Outdoor Drinking Fountain-Tri-Level Model

Standard Features

- Both Child and Adult ADA Compliant (when properly installed)
- Resistant to sunlight, heat, moisture and wear
- 18 gage, 304 stainless steel bowl
- 12 gage, heavy duty stainless steel, corrosion and scratch resistant finish
- Polished stainless steel, anti-rotation non-squirt bubbler
- 100 mesh inlet strainer
- Access door, heavy duty stainless steel, vandal resistant
- Vandal resistant stainless steel bottom plate

SUGGESTED SPECIFICATIONS

Round Pedestal Mount Outdoor Drinking Fountain Tri-Level model is a barrier free pedestal mounted, vandal resistant, tri-level round drinking fountain made from 18 gage, 304 stainless steel bowls mounted into a green powder coated 12 gage, heavy duty stainless steel pedestal. Unit shall be activated by front mounted self-closing buttons, by using less than 5 pounds of force, which activates internally mounted valves with adjustable stream regulators controlling the water flow. Bubblers shall be polished stainless steel with non-squirt features and operate on water pressure range of 20-105 psig. Fountain is certified to ANSI A117.1, Public Law 111-380 (NO-LEAD), CHSC 116875 and NSF/ANSI 61, Section 9. Fixture meets ADA, ADA Standing Person, and ADA Child requirements when mounted appropriately.



MODEL:

(Must Specify)

Satin stainless finish

Green powder-coated (Shown)

Red powder-coated

Blue powder-coated

Custom color finishes available upon request

OPTIONS

(additional costs may be incurred)

- FRU3 Freeze resistant, 3 valves ¹
- FRU4 Freeze resistant, 4 valves ¹
- FS Foot spray
- HB1 Hose bibb, compression, with hose threaded outlet/VB ^{1 2}
- HB2 Hose bibb, loose key, with hose threaded outlet/VB ^{1 2}
- HB3 Hose bibb, loose key, vandal resistant, with hose threaded outlet/VB ^{1 2}
- IGM In-ground 14" mounting
- JF1 Jug filler, spigot, self-closing valve with plain end ^{1 2}
- JF2 Jug filler, pushbutton, self-closing valve with plain end ¹
- NP3 Non-pollutable, freeze resistant, 3 valves
- NP4 Non-pollutable, freeze resistant, 4 valves
- PF Pet fountain receptor ¹

Options Notes:

¹ See separate option sheet.

² This option is not available freeze-resistant.

Complies with the following standards:



Member of
U.S. Green
Building
Council



Recyclable
Product



Water
Conserving
Product

WARNING: Cancer and Reproductive Harm - www.P65Warnings.ca.gov

BARRIER FREE, TRI-LEVEL, PEDESTAL MOUNTED DRINKING FOUNTAIN

IMPORTANT: INSTALLATION AND SITE PREP FOR FREEZE RESISTANT OPTIONS "-FRU, -NP" WILL DIFFER FROM STANDARD. REFER TO DESIGNATED FREEZE RESISTANT INSTALLATION DETAILS.

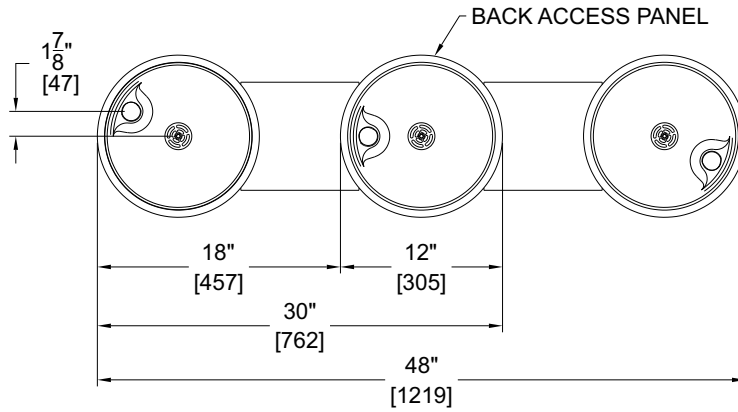

* Valve specifications:
Minimum/Maximum Pressure
30 to 100 psi.

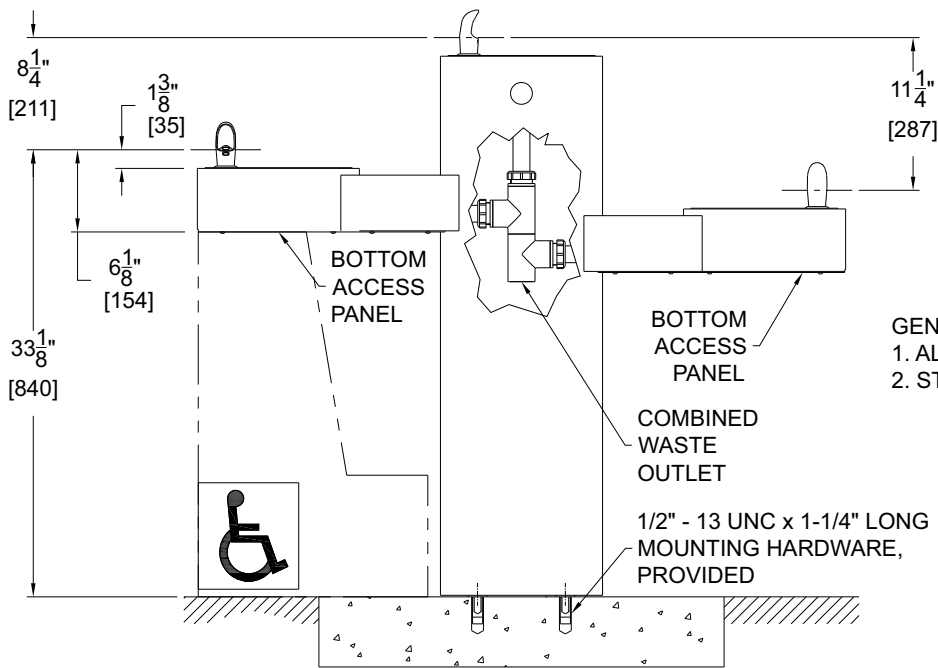

GENERAL NOTES:
1. ALL DIMENSIONS ARE IN INCHES [MM].
2. STOP VALVE NOT PROVIDED.