

# Foot Pedal-Operated Vintage Style Drinking Fountain

## STANDARD FEATURES

Foot Pedal-Operated Vintage Style Drinking Fountain is a drinking fountain of Victorian-era design. The control valve is located below the frost line to provide freeze resistant functionality. Activating the pedal raises or lowers the internal supply and waste column, controlling the valve. Constructed of cast iron with cast brass bowl, all brass parts and a stainless steel mainspring, this drinking fountain is equipped with an automatic stream control. Model M-1776 is designed for year-round use, trouble-free reliability and easy maintenance.

## SUGGESTED SPECIFICATIONS

Unit shall be capable of year-round use in freezing weather. Pedestal shall be heavy, one-piece iron casting extending from grade level to bowl. Pedestal shall be embossed with a decorative filigree and finished with a heavy grade of oil-based black enamel. Bowl shall be a round, polished solid brass casting. Drain opening in bowl shall adequately protected from stoppage or vandalism. Bubbler shall be polished solid brass casting with angle stream outlet at center of bowl and above bowl rim. Mouth guard shall be polished solid brass casting to meet sanitary requirements. All solid brass castings shall conform to ASTM standards B61 and B62. Valve and bubbler conform with lead-free requirements of Public Law 111-380 (NO-LEAD), CHSC 116875 and NSF/ANSI 61, Section 9. Valve shall be foot-pedal operated, spring-loaded to close. Pedal shall be aluminum bronze, finished with a heavy grade of oil-based black enamel. Mainspring shall be stainless steel wire with a minimum diameter of 0.225 inch (0.57 cm).

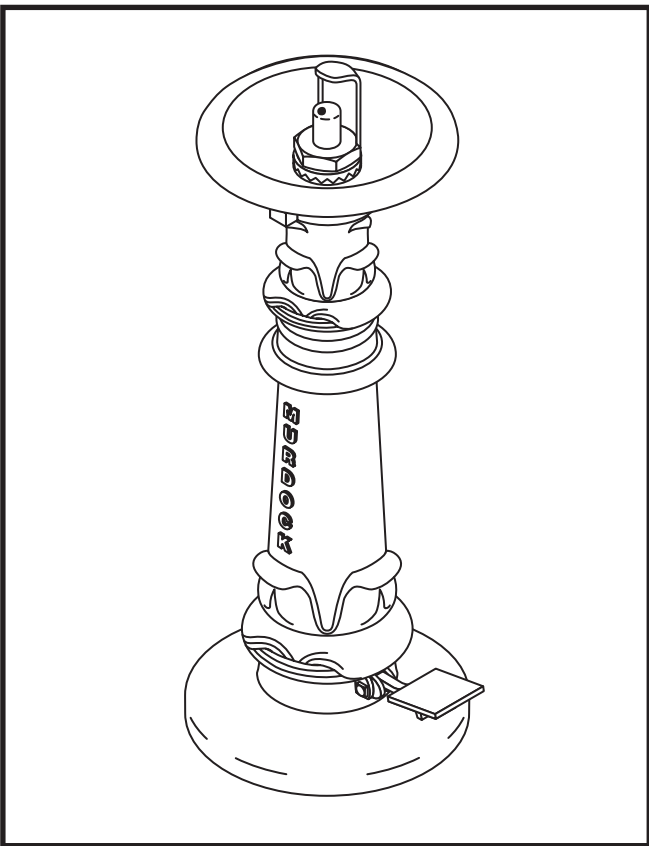

## DEPTH OF BURY

(additional costs may be incurred)

- 2 ft. (61 cm)
- 3 ft. (91.4 cm)
- 4 ft. (121.9 cm)
- Other \_\_\_\_\_
- 5 ft. (152.4 cm)
- 6 ft. (182.9 cm)

## OPTIONS

(additional costs may be incurred)

- BFH Double ball check valve\*
- **Black** Pedestal color black (standard)
- **Brown** Pedestal color brown
- **Green** Pedestal color green

Options Notes:

\* See separate option sheet.

Complies with the following standards:



Member of U.S. Green Building Council



Recyclable Product



Water Conserving Product

**WARNING:** Cancer and Reproductive Harm - [www.P65Warnings.ca.gov](http://www.P65Warnings.ca.gov)

# Foot Pedal-Operated Vintage Style Drinking Fountain

## FREEZE RESISTANT PEDESTAL DRINKING FOUNTAIN

