

Installer's Reference

UC-12-396-R0-012621

Tug Around

Know What's Below

As with all projects involving digging, start by knowing what is in the ground below. Underground utilities may include cable, electric, sprinklers, sewer, water, telecommunications, drainage pipes and sprinklers. You can usually accomplish this with one phone call (Dial 811) to your state's underground utility service.

Conduct an Inventory

Begin installation with of hardware and parts, assuring everything you need is onsite when you begin.

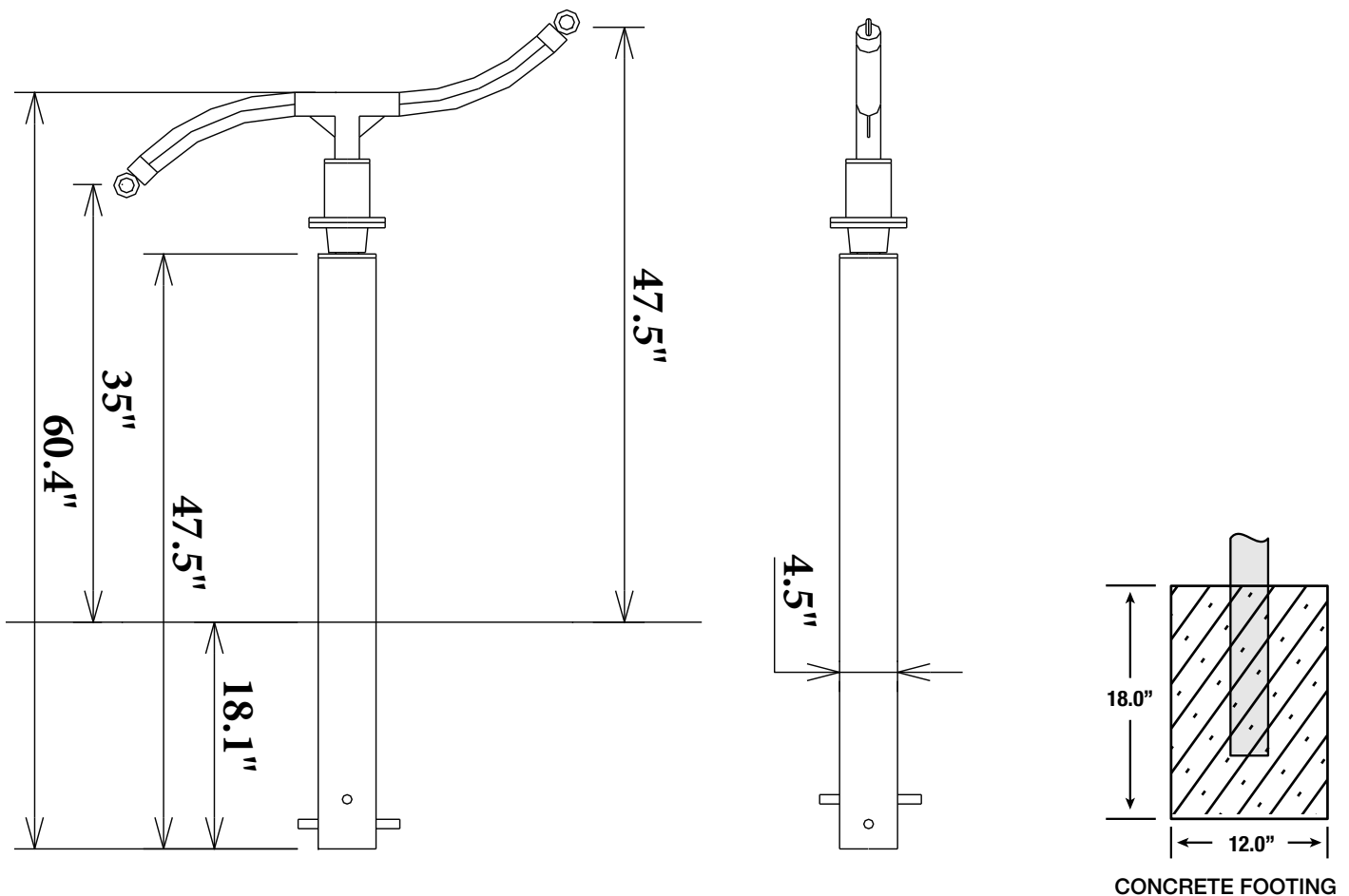

CONCRETE FOOTING