

TERRA BOUND

SOLUTIONS

MOON CRATER CLIMBER

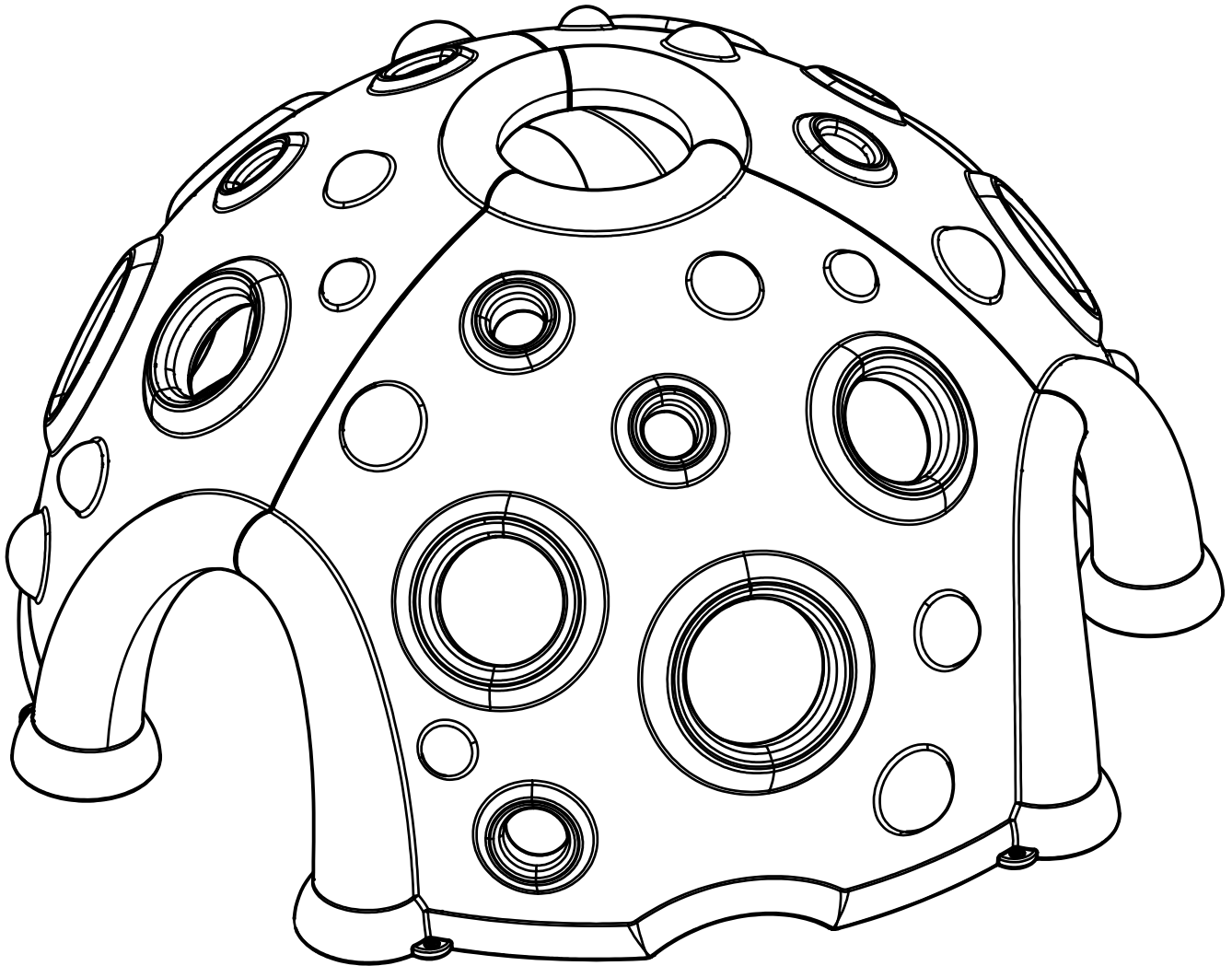

TERRA BOUND SOLUTIONS

MOON CRATER CLIMBER

Dear Terrabound Customer,

Thank you for choosing to purchase and install a Terrabound commercial playsystem. We appreciate the confidence you have placed in our company, and we will strive to earn your trust.

This is your Owner's Manual & Assembly Instructions booklet. We have designed this manual specifically for the products that you have purchased. Included in this manual you will find the following:

- Maintenance schedule & record
- Safety guidelines
- Warranty information
- Product installation instructions
- 2D top view drawings
- Ground plan

Please save this booklet for future reference.

The first several pages of this booklet contain important and valuable information regarding the general placement, installation and safety practices common to commercial play equipment. Please read this information carefully and use your best judgment as to how these guidelines apply to your specific situation.

If you have any questions concerning your new equipment, you can contact Terrabound Customer Service Representative at 1-877-857-2915

For more information on Terrabound and more products, please do not hesitate to give us a call or visit terraboundsolutions.com

Thank you for your business; we look forward to working with you on all of your future playground equipment projects!

Sincerely,

Terrabound Solutions

TERRA BOUND

SOLUTIONS

MOON CRATER CLIMBER

Parts List		
DESCRIPTION	QTY	PART NUMBER
MOON CRATER CLIMBER SIDE	3	02-07-0260
HARDWARE COMPLETE	1	33-12-0173
M10 x 65mm (2 9/16") BHCS BOLT	15	33-11-0018
M10 FLATWASHER	30	33-11-0200
M10 LOCK NUT	15	33-11-0400

Unless Otherwise Specified, All Units of Measure are Each

Items listed below Hardware Complete line are included with Hardware Complete Number

Warning: During Installation, Hardware And Small Parts Are Choking Hazards For Young Children. Store Unused Parts Appropriately Until Assembly Is Completed. Once Assembly Is Completed, Remove Any Unused Parts From The Play Environment And Dispose/Save Them In A Secure Location. Any bolt end protruding more than two full threads beyond the face of the nut causes risk of clothing entanglement.

Promptly cut-off flush, file smooth, and treat to prevent corrosion.

Note: Peen Tee-Nuts and Flatwashers to match radius of pipe after assembly is complete.

Note: Loctite (supplied by others) should be used on any non-patch hardware.

SPECIFICATIONS:

CLIMBER PANEL:

Shall be 3/8" wall thickness double wall construction, color impregnated linear low density polyethylene and shall conform to the rotationally molded specifications outlined herein. All polyethylene shall be linear low-density material with UV-stabilized color and an anti-static compound additive. All rotationally molded products shall meet or exceed the following specifications: ASTM D-1248, type 2, class A and Federal specification LP-390C, type 1, class M, grade 2, category 3; Density (ASTM D- 1505); Brittleness Temperature (ASTM D-746); Tensile Values (ASTM D-638); Flexural Modulus (ASTM D-790); Heat Distortion (ASTM-648); Low Temperature Impact (ARM-STD). Handholds shall be fabricated from a hybrid resin mixture with custom formulated UV inhibitor.

Powder Coat Finish:

Shall be an electrostatically applied custom formula of TGIC polyester powder. All components will be free of sharp edges and excess weld spatter and shall be cleaned in a four stage solvent/zirconium based bath system (free of iron phosphate), as a rust inhibitor, and a zirconium conversion coating to prevent flash rusting before coating. In addition, all welds shall be protectively coated with ZRP, a zinc rich primer that forms a rust-resistant barrier layer over each weld prior to application of the powder coating. The powder coating shall have a super tough finish with maximum exterior durability and will have superior adhesion characteristics. Typical characteristics are: Two coat process to achieve 3.0 - 5.0 mil thickness and oven cured between 375 to 425 degrees Fahrenheit. Pencil Hardness H (ASTM D-3363), Impact (ASTM D-2794-69), Wedge Bend (ASTM D-522-68), Adhesion (Cross Hatch ASTM D-3359 & Knife Scratch ASTM D-2197), Environmental (Stain Resistance ASTM D-1308, Humidity ASTM D-2247-87, Salt Spray ASTM B-117 & Fadometer 300 hrs with no loss of gloss), Over-bake Stability 200% at 350 degrees Fahrenheit for 10 minutes.

Hardware:

All nuts, bolts, screws, inserts, and lock washers used in the assembly of all play equipment shall be stainless steel, yellow dichromate plated steel, blue-coat plated steel, mechanically galvanized or powder coated/yellow dichromate plated steel. All primary fasteners shall be 304 alloy stainless steel. Fasteners with yellow dichromate treatment have an electro-deposited, 99.9% pure zinc substrate applied from a specially formulated solution sealed with a yellow dichromate top coat designed to work in conjunction with the zinc plating. Yellow dichromate has a 320% longer life to white corrosion and 275% longer to red corrosion than does hot-dip galvanizing. Stainless steel fasteners shall be button pin-in head, hex socket cap screws with a two-part epoxy locking patch added to the threads. The two-part locking patch shall consist of one part resin and one part catalyst which are activated during installation. After curing, the material shall require a minimum of five times the installation torque to remove the fastener. Manufacturer shall provide special installation tools for pinned fasteners.

TERRA BOUND

SOLUTIONS

INSTALLATION INSTRUCTIONS

INSTALLATION INSTRUCTIONS:

1. Determine the location of the Moon Crater Climber and dig the footing hole as shown in Top View. Refer to the Elevation View for footing depth.
2. Attach Moon Crater Climber Side to Moon Crater Climber Side using M10 x 65mm (2 9/16") BHCS Bolt, M10 Flatwasher, and M10 Lock Nut. See Detail 070.
3. Plumb and level the entire assembly and tighten all fasteners.
4. After entire unit is assembled, pour concrete footings within 4" to the top and taper away from post for water drainage. Allow to cure at least 48 hours before use. Temporary bracing may be required until concrete cures.
5. Check that all hardware connections are securely tightened. Smooth away any sharp edges that may have been created during handling and assembly. Install resilient surfacing within the use zone of play structure in accordance with ASTM specifications F1292, and appropriate for the fall height of each structure. Refer to all applicable safety guidelines.

MAINTENANCE PROCEDURE:

Periodically check hardware for tightness, and tighten as necessary. Always check all parts for breakage or wear, and immediately put equipment out of service until any faulty parts found are repaired or replaced. Also Check all metal parts for rust, paint loss and touch-up if necessary with paint. Check for welded areas and verify integrity. Check periodically resilient surfacing for appropriate depth and remove extraneous materials that could cause injury, infection, or disease. Maintain detailed installation, inspection, maintenance, and repair records for each public-use playground equipment.

TERRA BOUND

SOLUTIONS

TOOLS REQUIRED

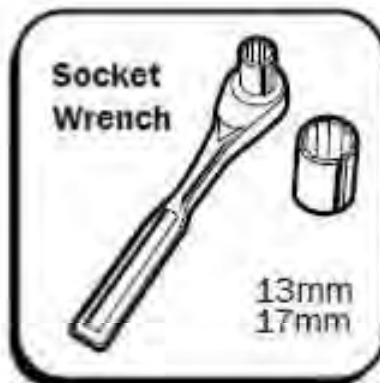
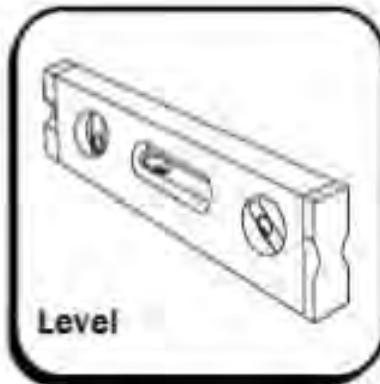

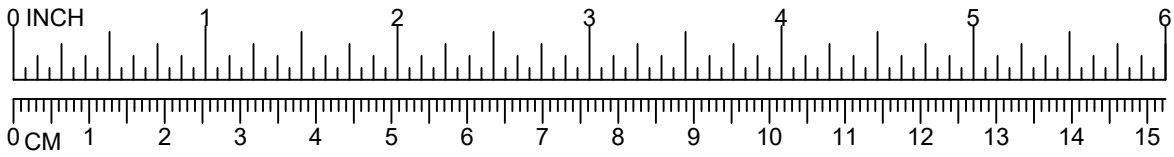

HARDWARE REFERENCE

M8 B.H.C.S. Bolts

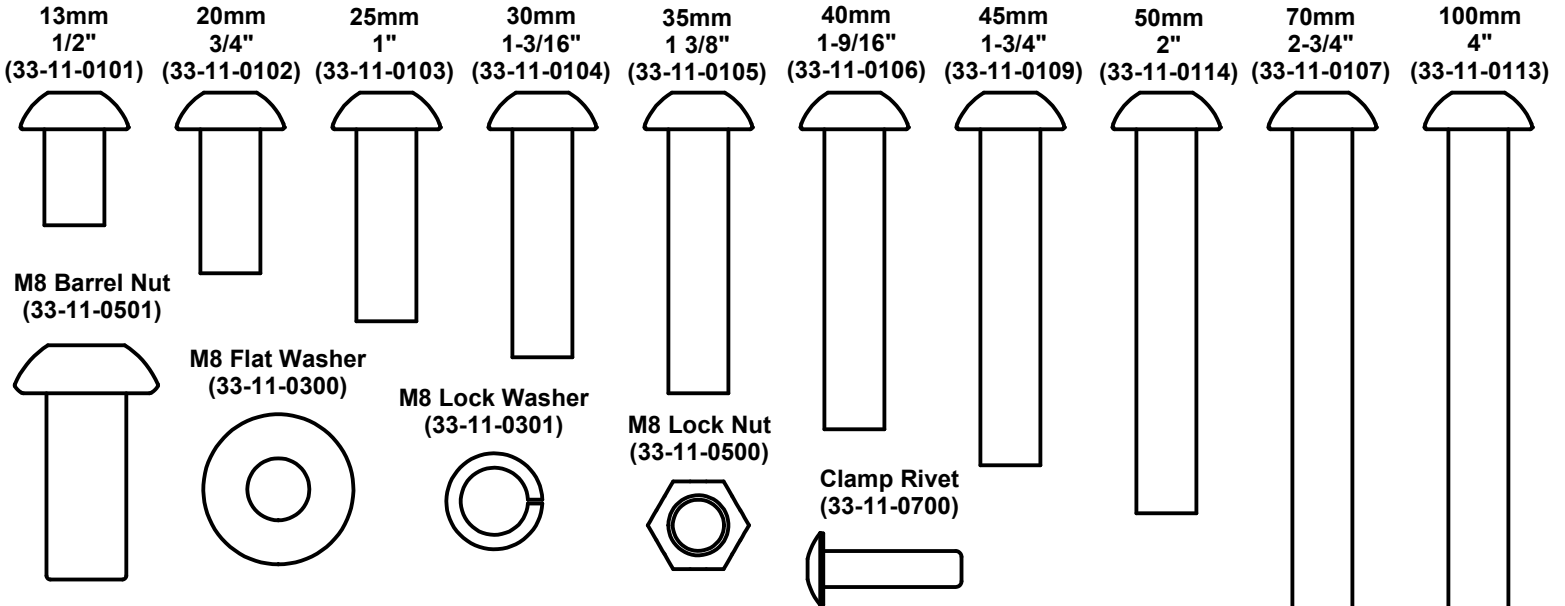

18" Ground Spike (Not to Scale)
(02-07-0048)

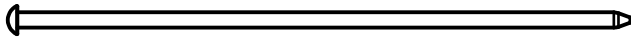

M5 x 76mm (3") Self-Tapping Screw
(33-11-0600)

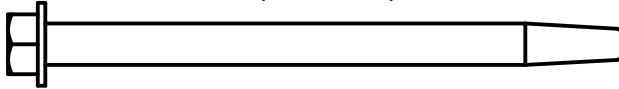

M10 Lock Washer
(33-11-0201)

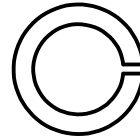

M10 Flat Washer
(33-11-0200)

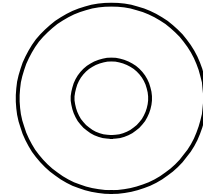

M10 Lock Nut
(33-11-0400)

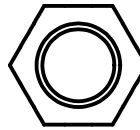

M10 T-Nut
(33-11-0402)



13mm
1/2"
(33-11-0001)

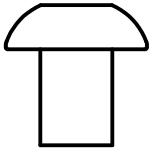

80mm
3-1/8"
(33-11-0011)

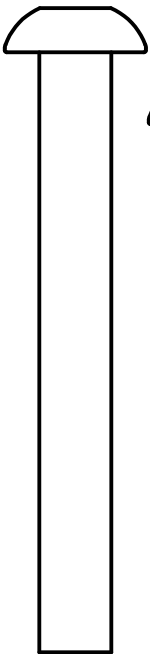

70mm
2-3/4"
(33-11-0008)

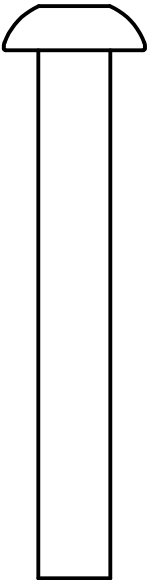

60mm
2-3/8"
(33-11-0007)

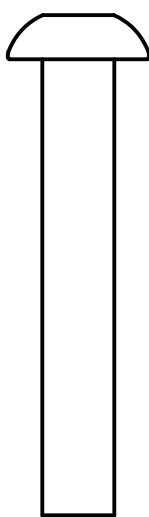

50mm
2"
(33-11-0010)

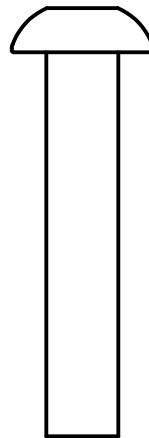

45mm
1-3/4"
(33-11-0013)

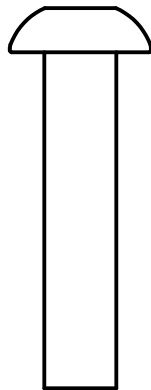

40mm
1-9/16"
(33-11-0006)

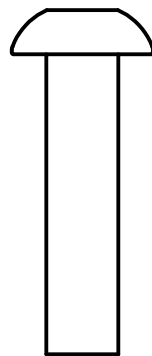

35mm
1-3/8"
(33-11-0005)

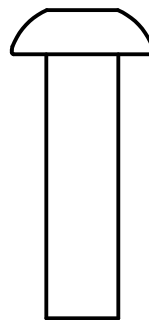

30mm
1-3/16"
(33-11-0004)

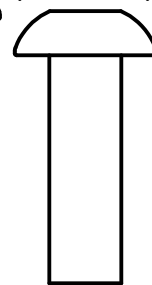

25mm
1"
(33-11-0003)

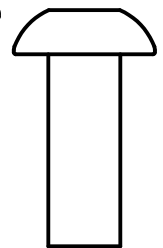

20mm
3/4"
(33-11-0002)

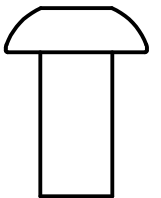

TERRA BOUND SOLUTIONS

USE ZONE

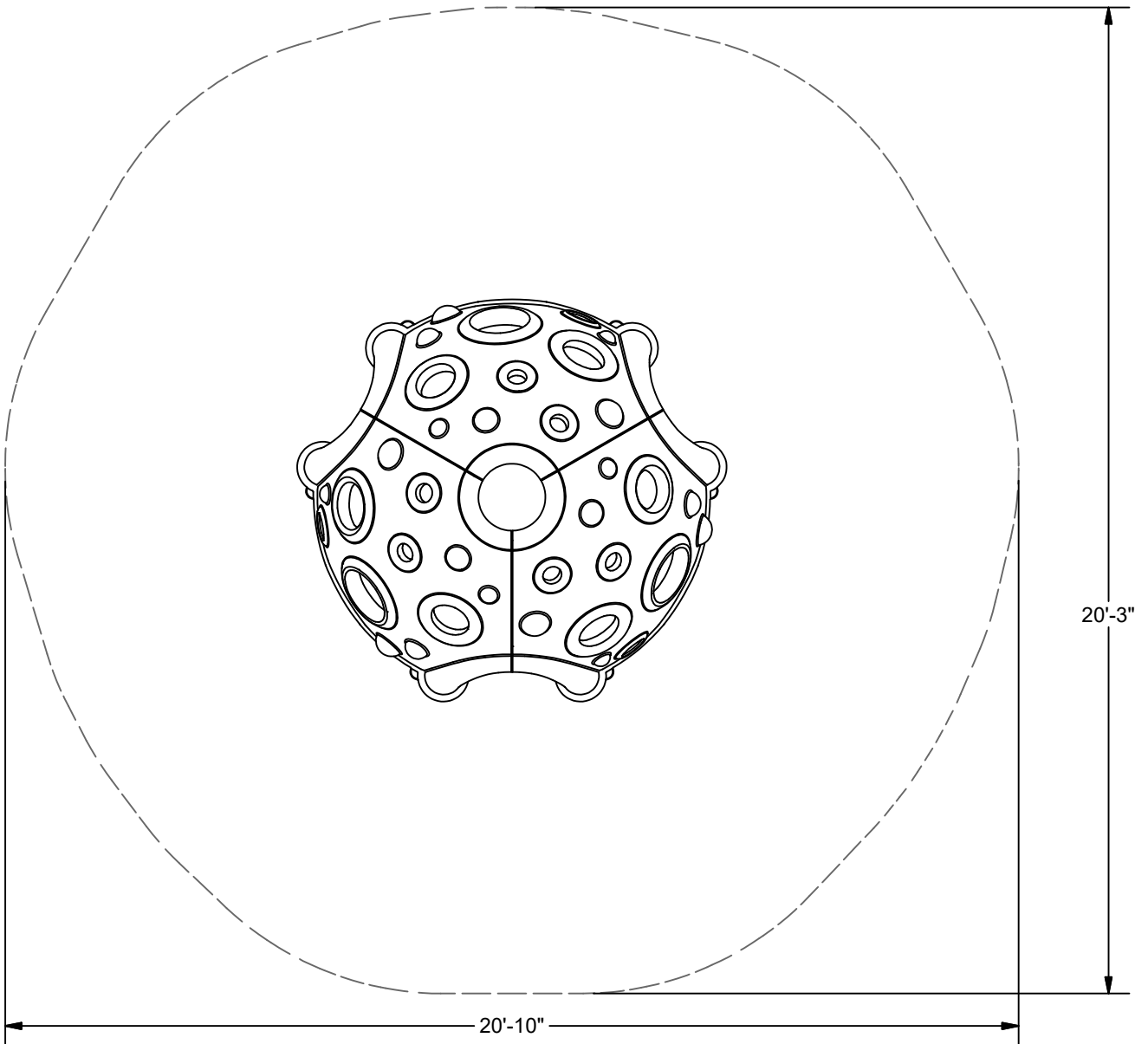

MINIMUM USE ZONE* REQUIRED

**The USE ZONE is the area beneath and immediately adjacent to a play structure or equipment that is designed for unrestricted circulation around the equipment and on whose surface it is predicted that a user would land when falling from or exiting the equipment.*

NOTE:

Equipment shall be positioned to eliminate conflicting traffic patterns. As a general rule, allow at least 3' of freespace around the entire structure.

IMPORTANT: Never install play equipment over hard, unresilient surfaces such as asphalt, concrete, or compacted earth. It is the owner's responsibility to ensure the "minimum area required" contains an appropriate amount of resilient material to cushion accidental falls.

TERRA BOUND

SOLUTIONS

ELEVATION VIEW

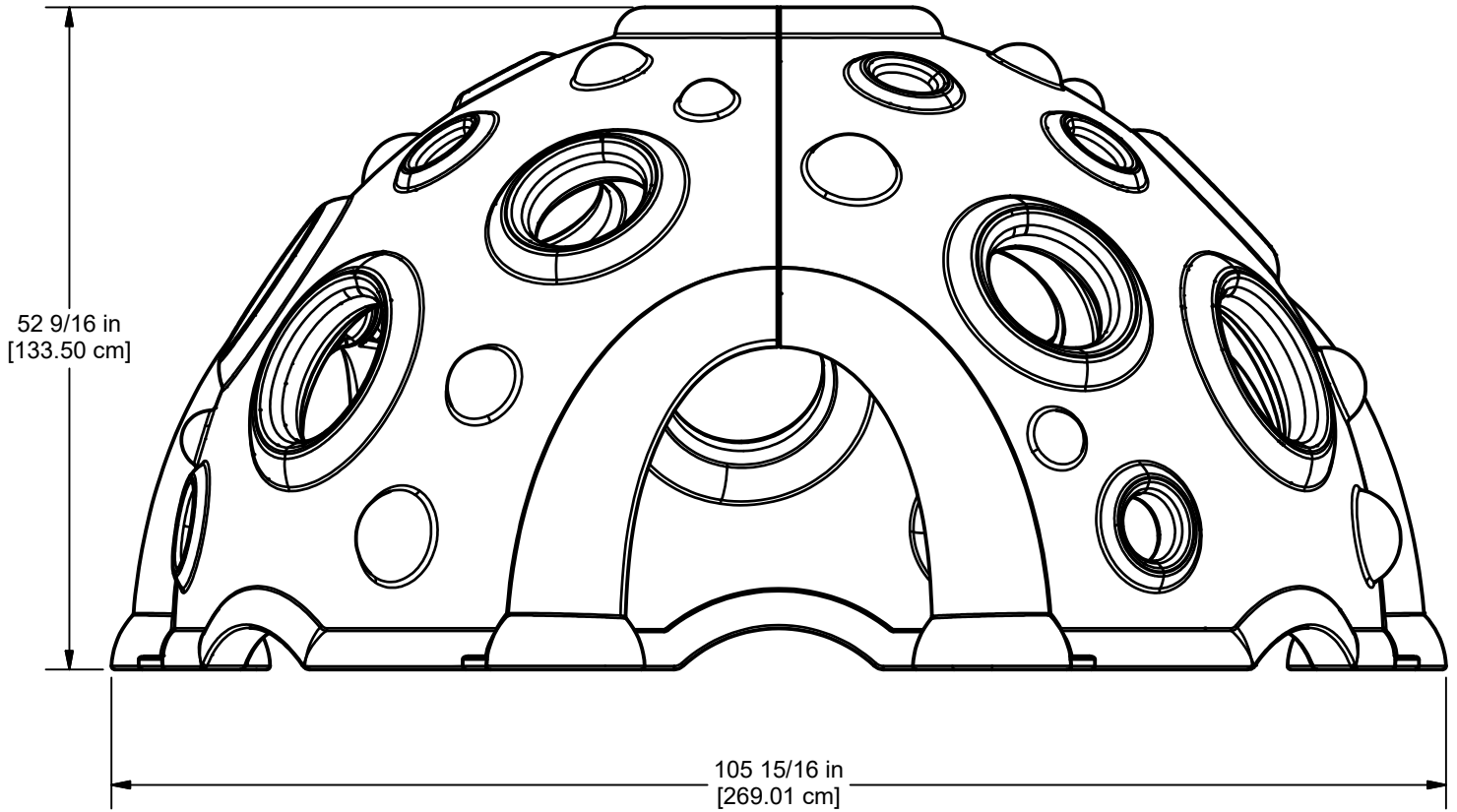

ELEVATION VIEW

TERRA BOUND SOLUTIONS

UPRIGHT PLACEMENT

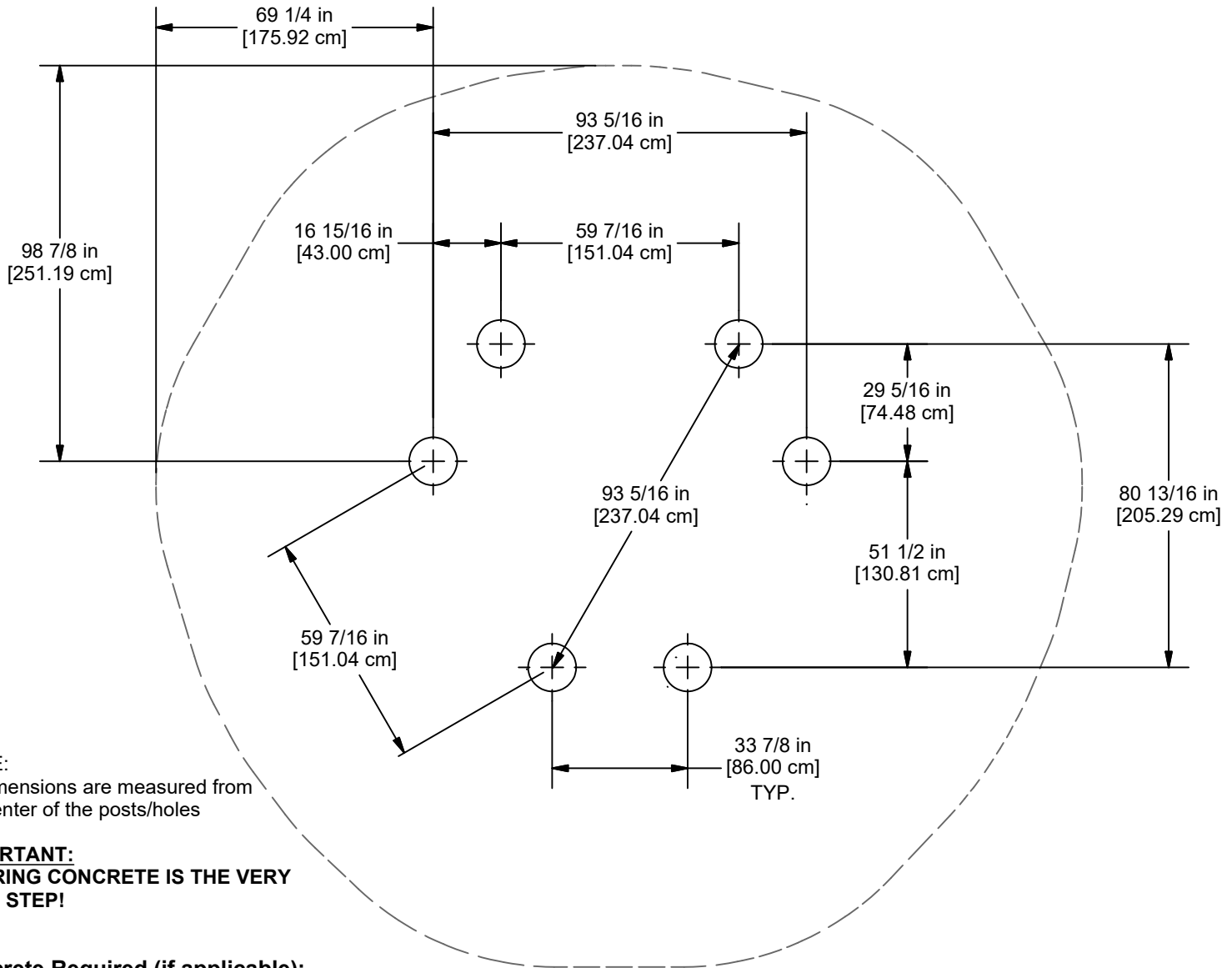

NOTE:
All dimensions are measured from the center of the posts/holes

IMPORTANT:
POURING CONCRETE IS THE VERY LAST STEP!

Concrete Required (if applicable):
Approx: .145 Cubic Yards (.111 Cubic Meters)
NOTE: Suggested Min. concrete rating: 3000PSI

IMPORTANT: Never install play equipment over hard, unresilient surfaces such as asphalt, concrete, or compacted earth. It is the owner's responsibility to ensure the "minimum area required" contains an appropriate amount of resilient material to cushion accidental falls.

○ Placement for 12" Diameter x 20" Deep Holes for In-ground installation

1. Review Use Zone. Mark the placement of one Inground Footer. Any of the (6) may be used.

NOTE: Survey flags may be used to mark the placement of each hole.

2. Measure from first Inground Footer to mark the position of the remaining (5) Footers.

NOTE: All remaining dimensions are based off of the Inground Footer placement.

TERRA BOUND SOLUTIONS

FOOTING DETAIL - SURFACE MOUNT (02-07-0262)

Parts List		
DESCRIPTION	QTY	PART NUMBER
CONCRETE ANCHOR	6	33-11-0702

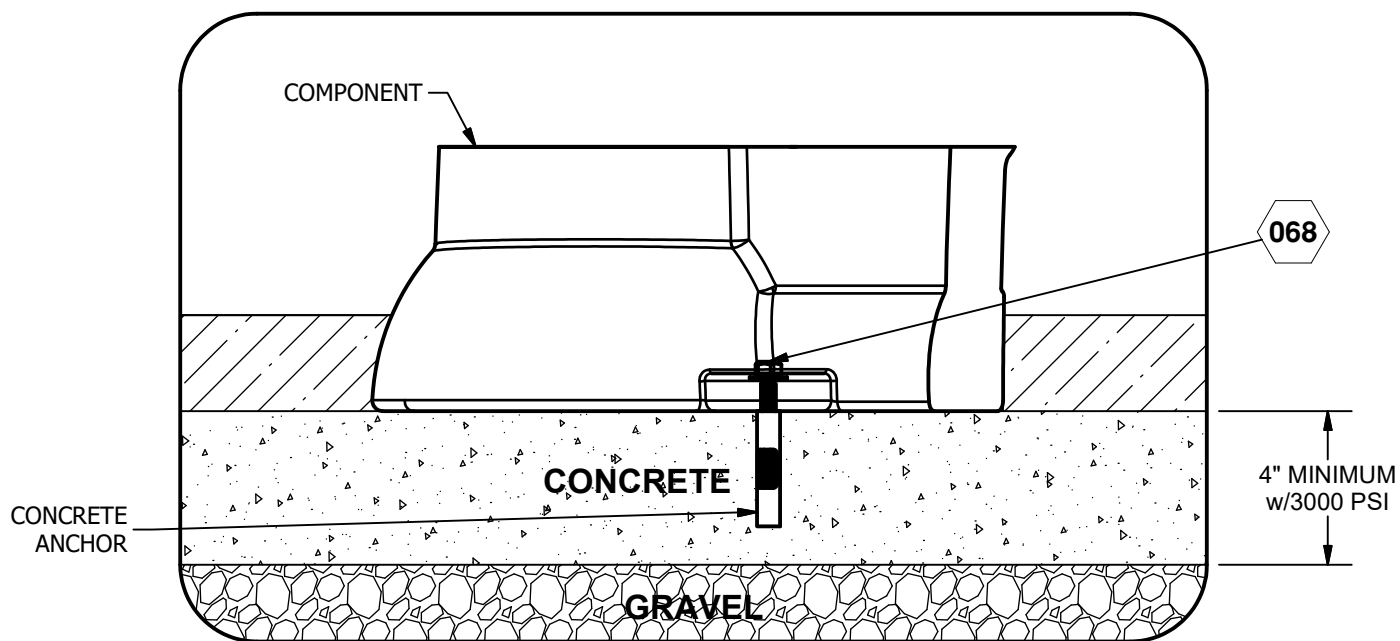

IMPORTANT: Never install play equipment over hard, unresilient surfaces such as asphalt, concrete, or compacted earth. It is the owner's responsibility to ensure the "minimum area required" contains an appropriate amount of resilient material to cushion accidental falls.

SITE PREPARATION

Clear area of any debris and level surface. Equipment is designed to be installed on a level surface.

TERRA BOUND

SOLUTIONS

FOOTING DETAIL - SURFACE MOUNT

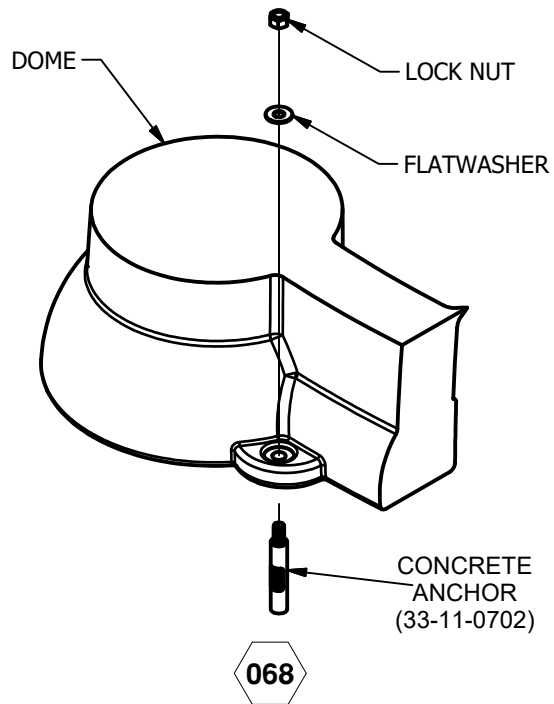

TERRA BOUND SOLUTIONS

FOOTING DETAIL - IN GROUND (OPTIONAL) (02-07-0261)

Parts List		
DESCRIPTION	QTY	PART NUMBER
INGROUND FOOTER	6	02-07-0237
M10 x 35mm (1 3/8") BHCS BOLT	6	33-11-0005
M10 FLATWASHER	12	33-11-0200
M10 LOCK NUT	6	33-11-0400

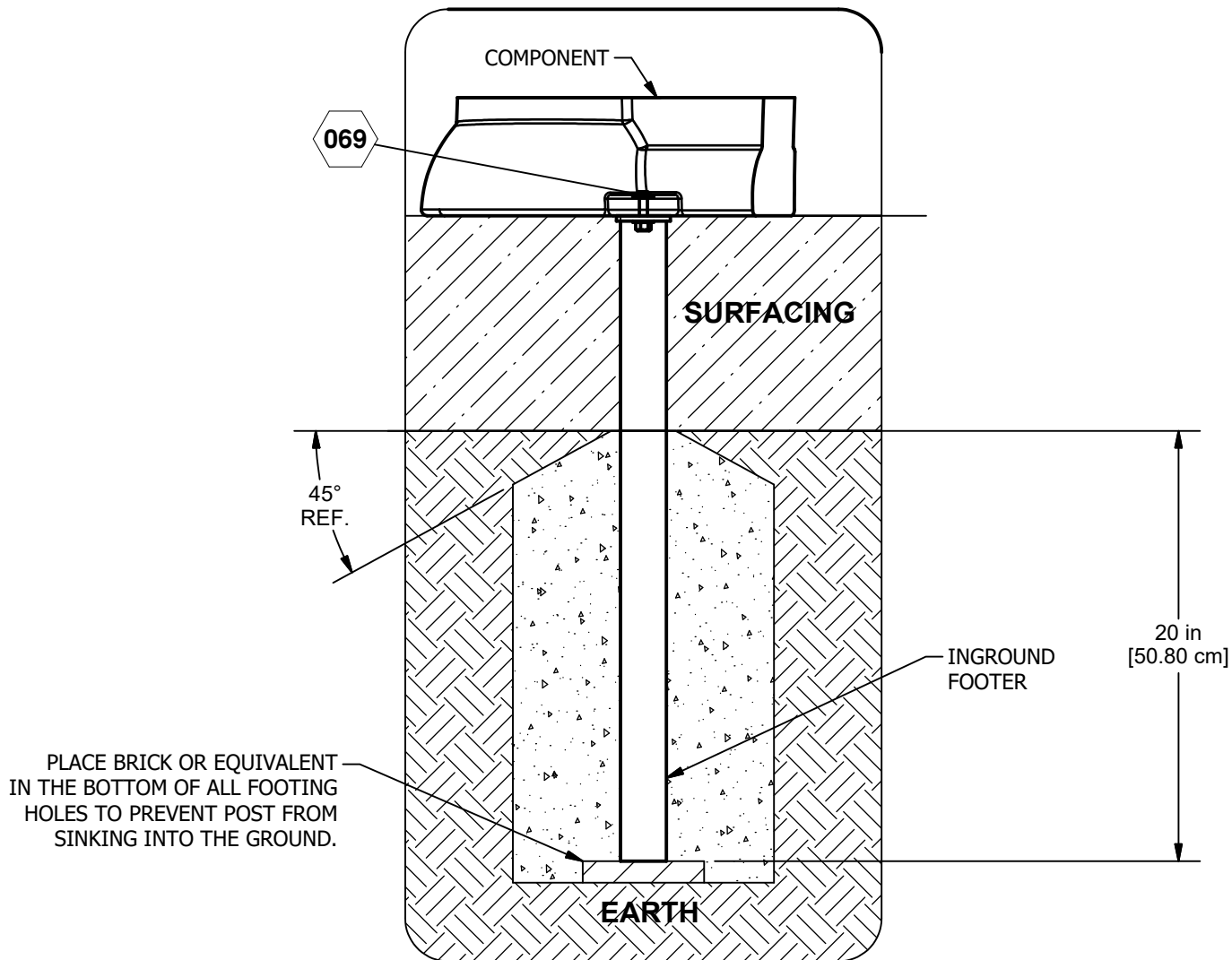

IMPORTANT: Never install play equipment over hard, unresilient surfaces such as asphalt, concrete, or compacted earth. It is the owner's responsibility to ensure the "minimum area required" contains an appropriate amount of resilient material to cushion accidental falls.

SITE PREPARATION

Clear area of any debris and level surface. Equipment is designed to be installed on a level surface.

TERRA BOUND SOLUTIONS

FOOTING DETAIL - IN GROUND (OPTIONAL)

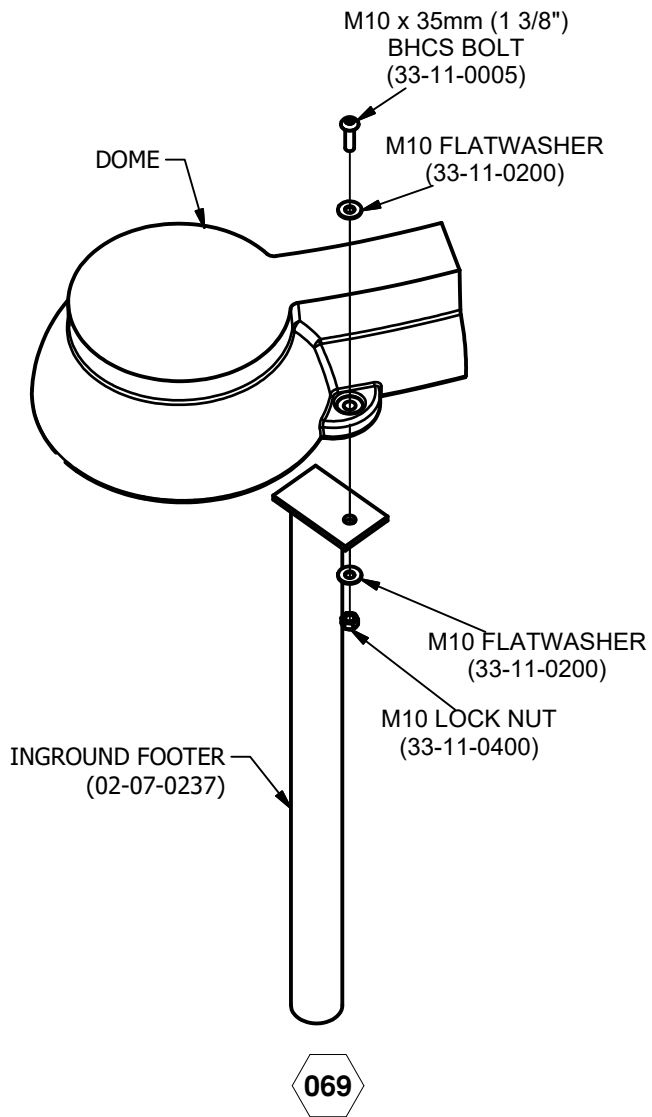

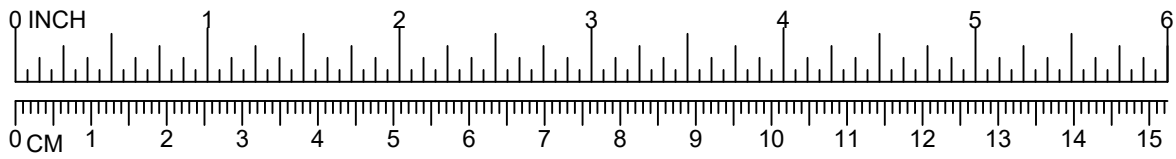

MOON CRATER CLIMBER

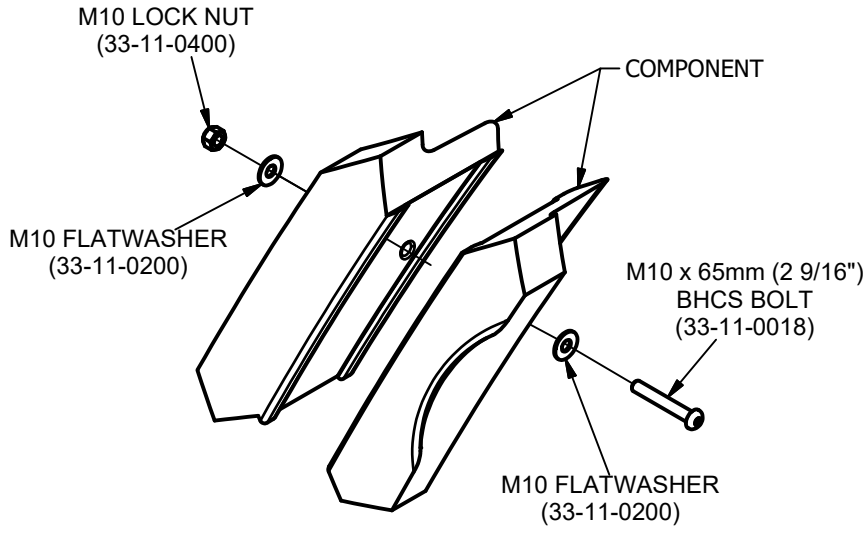

070

TERRA BOUND

SOLUTIONS

MOON CRATER CLIMBER

MOON CRATER CLIMBER SIDE
(02-07-0260)

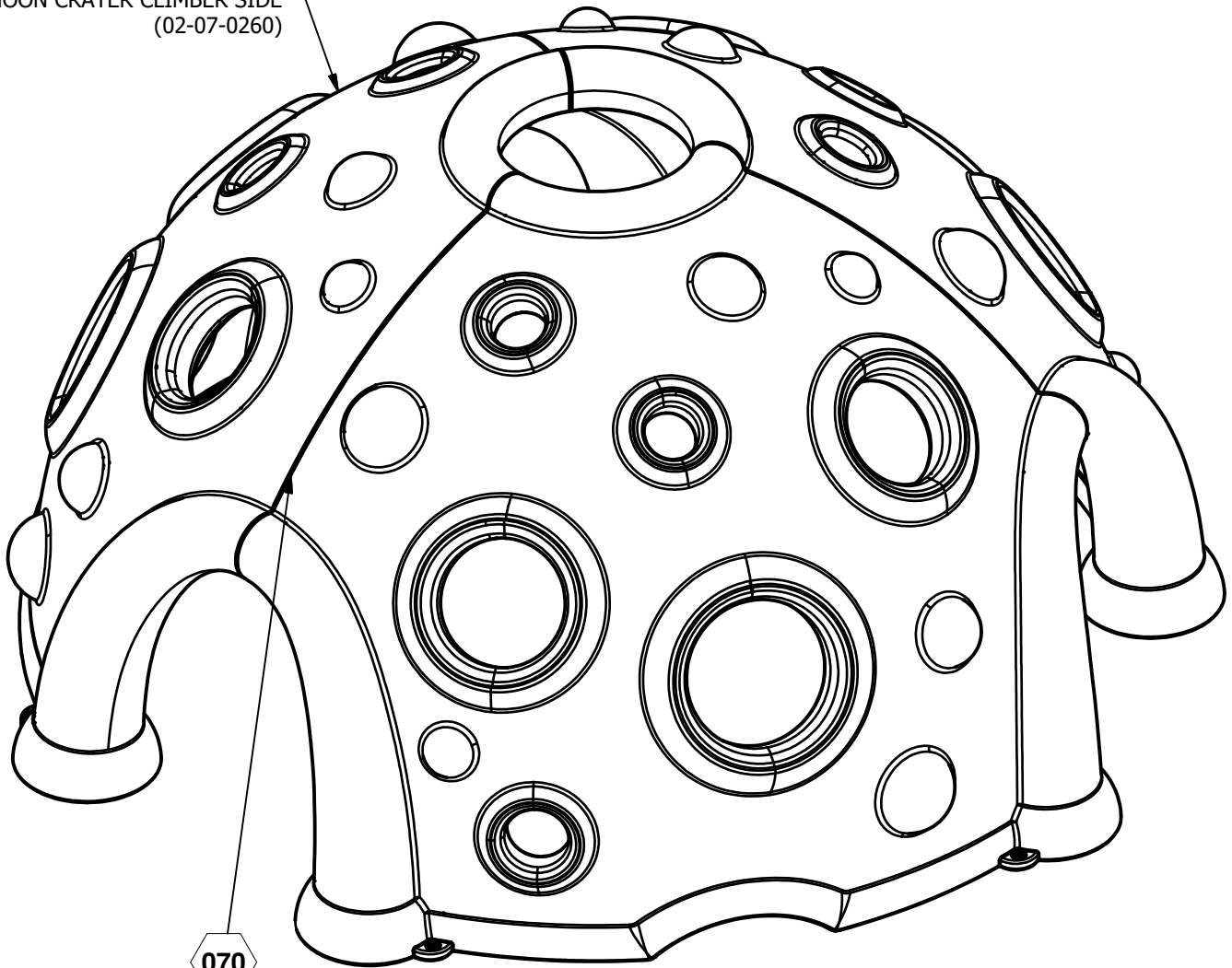

070
UNDERNEATH

FINISHED ASSEMBLY

 = INSTALLATION DETAIL