

# MANTA RAY INSTALLATION GUIDE

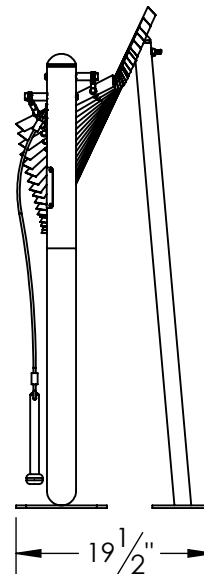
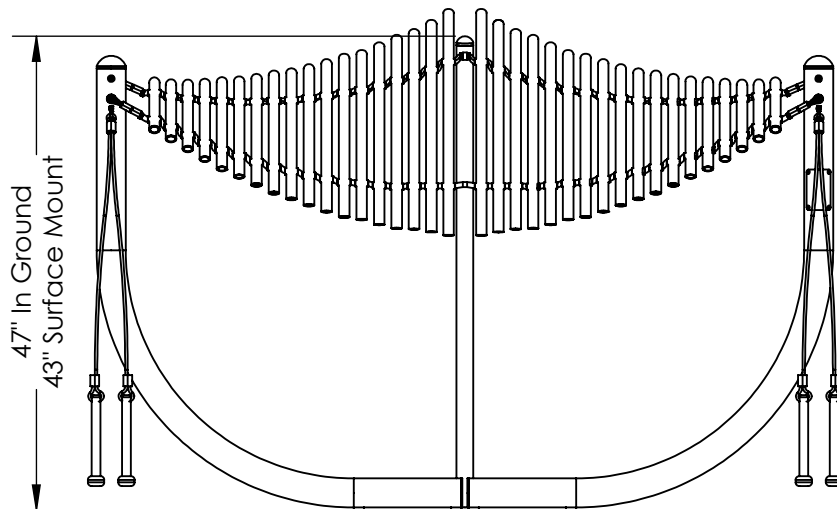
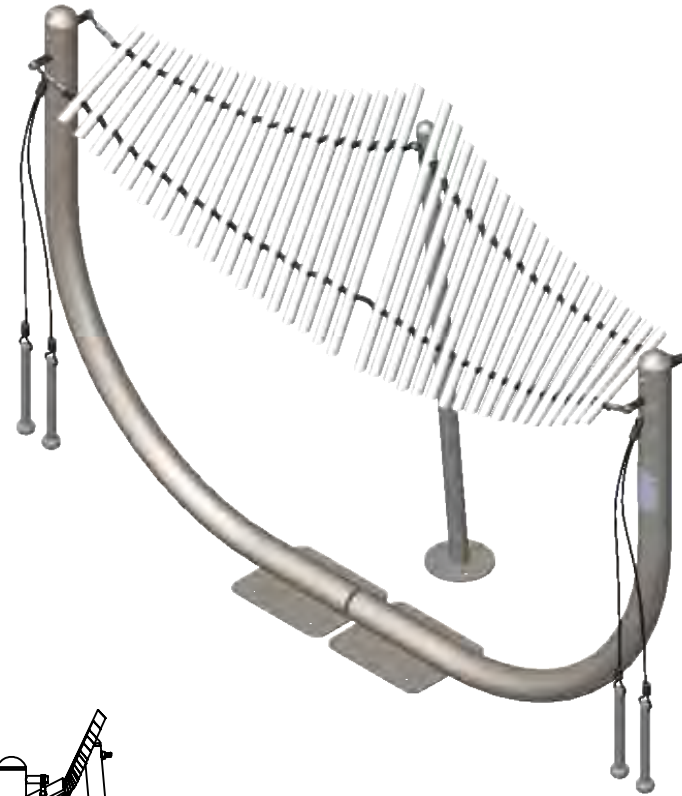
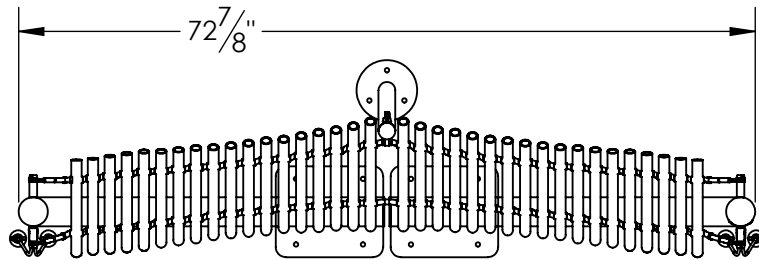

## Main Features:

- C Major Diatonic
- Powder Coated Steel Frame
- Anodized Aluminum Chimes
- Stainless Steel Hardware

## Contents:

- SHEET 2 - In Ground and Surface Mount Installation w/ Parts List
- SHEET 3 - Chime Installation

## Weights:

- Instrument Weight, 116lbs.
- Boxed Instrument Weight, 140lbs.

**Step 1:** Determine installation location. Verify concrete footing is a minimum of 36" long x 24" wide x 6" thick. If the concrete pad is at an angle, steel washers are required to act as shims (Shims not provided). If there is not already an existing pad, approximately (5) 80lb. bags will be needed. Allow concrete to cure per concrete manufacturers guidelines.

(If a In-Ground appearance is desired recess the concrete pad 4" below finished grade)

**Step 2:** With two people place the Uprights individually onto the concrete pad and mark the center of the holes on the surface mount plates. Use the diagram below as a guide for Upright placements. After you have made your marks, set aside the Uprights in order to drill for anchor holes. With a hammer or rotary drill, drill through concrete at marked locations. Drill to a minimum depth of 4". A 3/8" masonry drill bit will be needed.

**Step 3:** Place the Uprights back over the drilled out holes. Insert provided anchor bolts into aligned holes. Position anchor nut so that it is flush with the top of the bolt. Pound anchor bolts into the hole until the anchor washer is flush with the Upright Bases. Tighten anchor bolts until they are snug. Cover remaining bolt sections with provided nut caps.

**Step 4:** Verify the correct placement, levelness, and finished height of the instrument. Also check for sufficient clearance around the instrument. A 36" perimeter around the instrument is recommended for wheelchair accessibility.

**Step 5:** If installing onto wet concrete, use the wet set anchor manufacturers guidelines for installation procedures.

**Parts List:**

ITEM NO.	PART DESCRIPTION	QTY.
1	Steel Outer Upright	2
2	Steel Inner Upright	1
3	3/8"-16 Wedge Expansion Anchor, 3.75"lg. SS	11
4	35/64" Hex Nut Cap	11
5	Manta Ray Chime Assembly	1
6	3/8"-16 Button Head Screw, 5"lg. SS, Hex Drive	4
7	3/8"-16 Tri-Groove Nut, Zn	5
8	ø13/32" ID x ø7/8" OD, Washer SS	8
9	ø.385" ID x ø3/4" OD Spacer, 1.5"lg. LDPE	4
10	Blue Locktite	1
11	#30 Square-Drive Socket	1

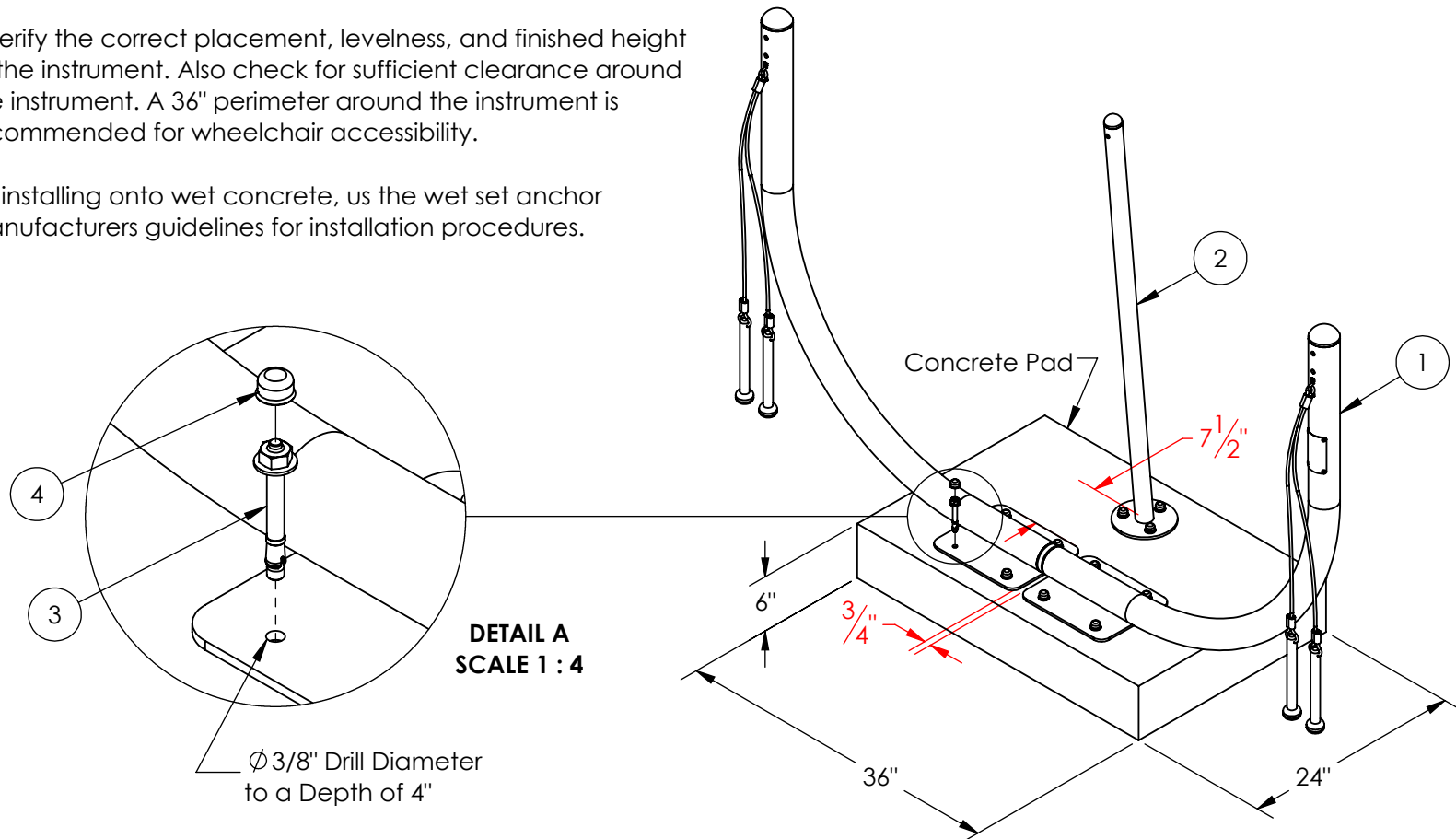

**Step 1:** After the Inner and Outer Uprights have been properly installed attach the Chime Assembly to the Uprights.

**Step 2:** Follow the diagrams below for installation of the Chime Assembly. Before installing the tamper-resistant nuts, apply the provided blue locktite to the threads of the 5 bolts on the Chime Assembly. After the blue locktite is applied, fasten down nuts with the provided #30 Square-Drive Socket.

