

Model # BARK-527SM

SAFETY WARNINGS & EQUIPMENT INSPECTION

- Owners and installers please note these safety warnings and make use of this checklist on a regular basis.
- Follow installation instructions when erecting equipment.
- Ground surfaces around equipment should be restored as needed. Concrete footings should never be exposed. Surface depth should comply with ASTM and CPSC specifications.
- Check for and repair damage caused by wear or vandalism, a major factor in injury causing situations.
- All protruding bolts should be covered or cut off and finished smooth. Sharp edges on pipes should be capped or removed. Check for bent, broken, or severely worn pipe, and replace.
- All equipment should be free of rust and repainted whenever necessary to deter rusting.
- We provide our customers with layout sheets and installation instructions. Please keep on file the specifications sheet that contains the listing of every part used.
- Never add components not intended for use with this product.
- Regular maintenance is necessary in this and all park and recreational equipment to insure the safety of the user.
- Note: Proper maintenance of equipment requires regular tightening of all bolts, nuts, and setscrews.
- Note: Regular checking of all parts, castings, etc. should be made. If a part is broken or worn, it should be replaced immediately.
- Check to be sure all fittings are tight and that bars and pipes do not move.
- Replace all worn S-hooks. S-hooks must be completely closed. Failure to close S-hooks can result in serious injury to the user. NEVER reuse S-hooks.
- Test for free movement of swing hanger and other moving attached parts.
- Check for worn chains and replace them.
- A soft resilient surface should be placed under all swings extending at least twice the height of the top rail both front and back.

HARDWARE



5/16" x 3-1/2"
Carriage Bolt (SS)



5/16" Washer (SS)



5/16" Kep Nut (SS)

TOOLS REQUIRED

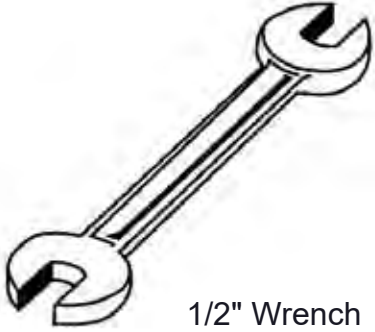

1/2" Wrench



1/2" Socket Wrench



Tape Measure

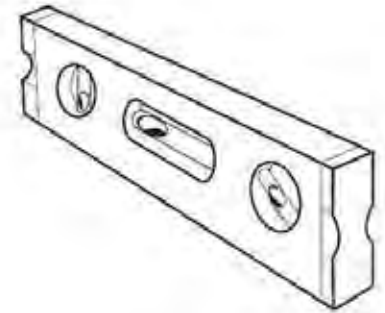

Level

BARK PARK PRODUCT SPECIFICATIONS

BARK-527SM

Aluminum Sign: 12 gauge aluminum precision cut with a graphic applied.

Frame: Posts are 3" square tubing with steel caps. Leash hangers are made of .625" OD round stock. 8" sq x 1/4" thick surface mount plate.

Frame Coating: Electrostatic powder coated application oven cured.

Hardware: All stainless steel hardware.

Dimensions: Leash Post Assembly is 50-1/4" tall x 14" x 14".

COMPONENTS

Attach the Leash Post Aluminum Sign to the Posts as shown using the specified hardware.

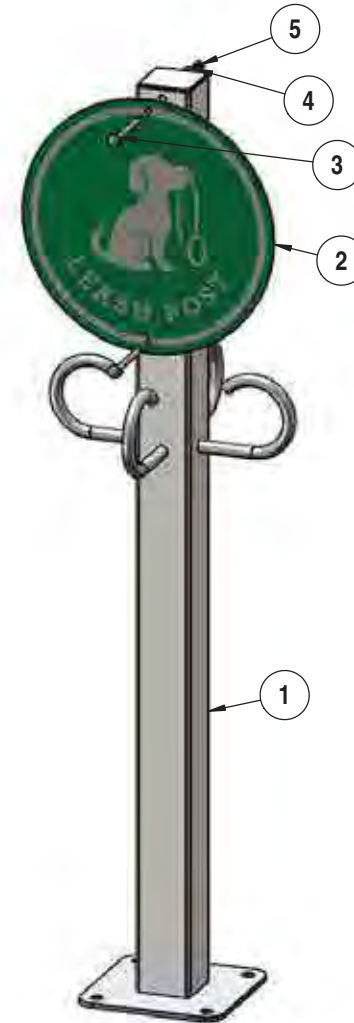

ITEM NO.	PartNo	DESCRIPTION	QTY
1	01-08-0368	BARK-526/527 Post Assembly SM	1
2	01-08-0374	Bark-527 Aluminum Sign	1
3	33-06-0121	5/16" x 3-1/2" Carriage Bolt (SS)	2
4	33-02-0007	5/16" SS Washer	2
5	33-03-0012	5/16" Kep Nut (SS)	2

Recommended Surface Mount Hardware:
3/8" x 3-1/2" Concrete Expansion Anchor Bolts
(Not Included)

OVERALL DIMENSIONS

