

Installation Instructions MBBP-6 (Bolt-on Edge Padding)

Carton Contents (Bill of Material):

<u>Qty</u>	<u>Description</u>
2	Molded Backboard Padding
8	1/4-20 x 3" Pan Head Machine Screw
8	1/4-20 x 1" Pan Head Machine Screw
8	1/4-20 Serrated Flange Nut
2	1/4" OD Edge Pad Assembly Alignment Rod
1	Installation Instruction Sheet

Tools Required:

- Phillips screwdriver with #2 or #3 bit
- (Following are only required for other backboard brands)
- Portable drill with 5/16" drill bit
 - Masking tape
 - Utility knife
 - Tape measure
 - Center punch

2. Using a tape measure, mark the centerline of the backboard. Place one of the pads in position on the backboard. Use masking tape to hold it in position for locating the mounting holes. For best fit, line up the first pad with the centerline and then place the second pad next to the first in step 5.
3. Using a center punch, mark the hole locations for the drilled holes.

IMPORTANT: Always use the hole location toward the rear of the backboard to avoid drilling into the backboard glass!

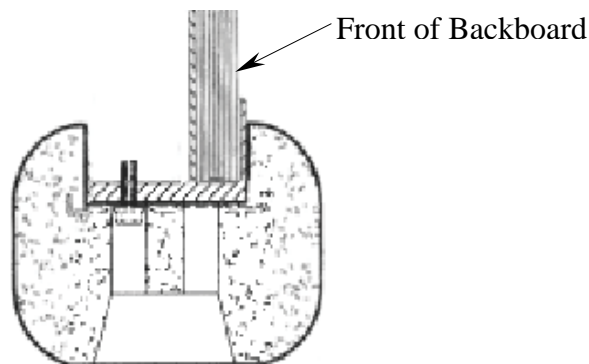

Figure 1: Holes Drilled Through Frame - Towards Rear of Board

4. At the marked locations, use a 5/16" drill bit to drill through the backboard frame.
5. Select either the 1" or 3" bolts, and bolt the first edge pad into place. Fit the second edge pad in place and repeat steps 2 through 5.

NOTE: The 1" bolt is sufficient for all glass backboards, and for all others with thin metal frame (nuts required only for the latter). 3" bolts are required for boards with reinforced frame or tube steel bottom frame.

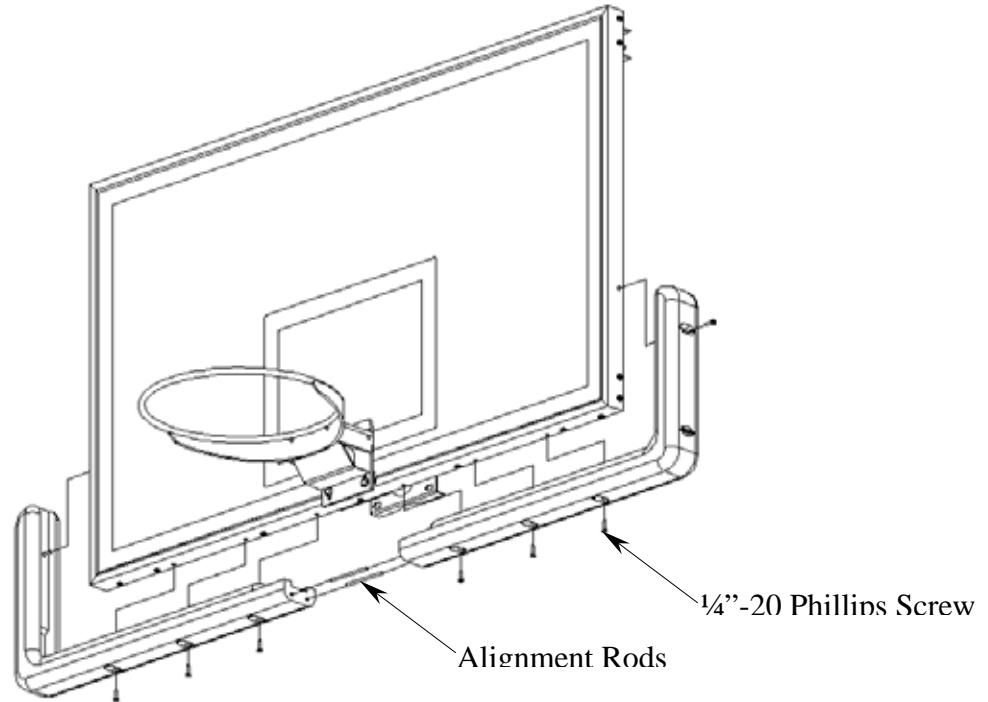

Figure 2: Assembly of Edge Pad Onto Backboard

TIP: Leave all bolts loose until both edge pads are in place, then stretch both pads towards the center and tighten bolts. This will minimize any gap between the pads, as well as insure the best quality installation and reduce any chance of pads separating when players hang on them.

