

Installer's Reference



Me and My Pal Bench

Models BAR70080 and BAR70080S

Know What's Below

As with all projects involving digging, start by knowing what is in the ground below. Underground utilities may include cable, electric, sprinklers, sewer, water, telecommunications, drainage pipes and sprinklers. You can usually accomplish this with one phone call (Dial 811) to your state's underground utility service.

Conduct an Inventory

Begin installation with of hardware and parts, assuring everything you need is onsite when you begin.

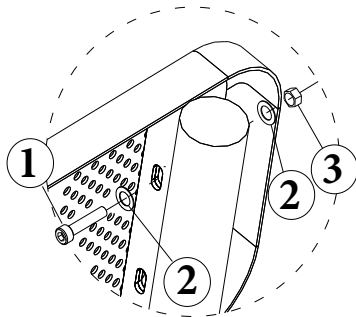
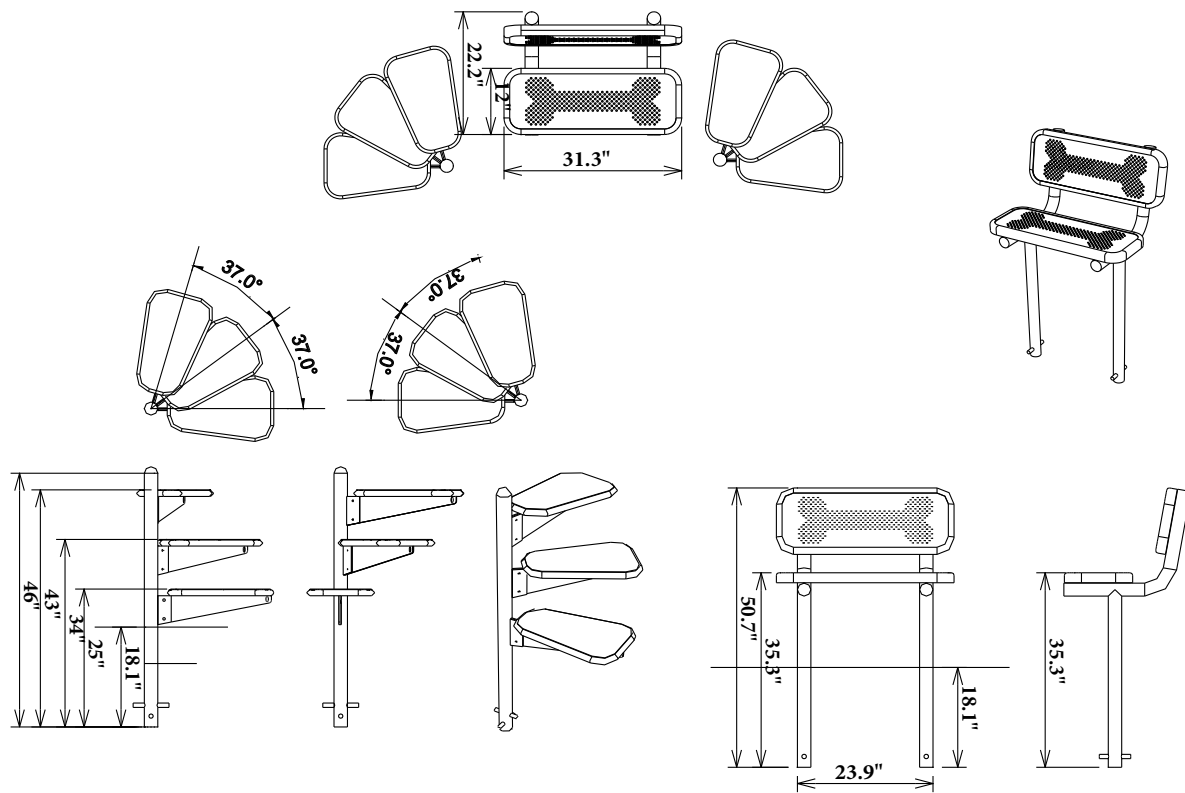

1. TAMPER RESISTANT TORX-BOLT, M10x30 (8)
2. FLAT WASHER, M10 (16)
3. LOCK NUT, M10 (8)

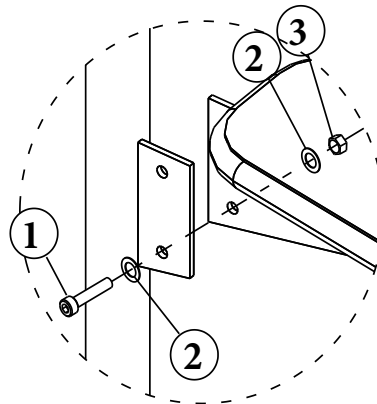
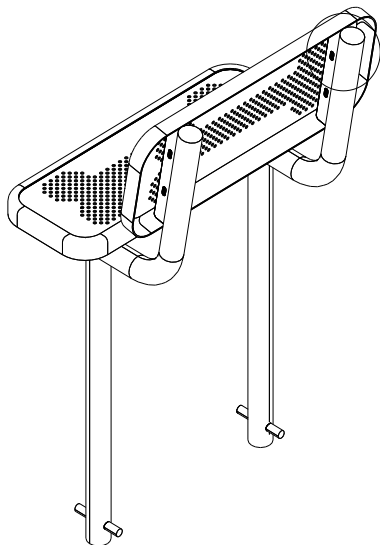

1. TAMPER RESISTANT TORX-BOLT, M10x30 (6)
2. FLAT WASHER, M10 (12)
3. LOCK NUT, M10 (6)

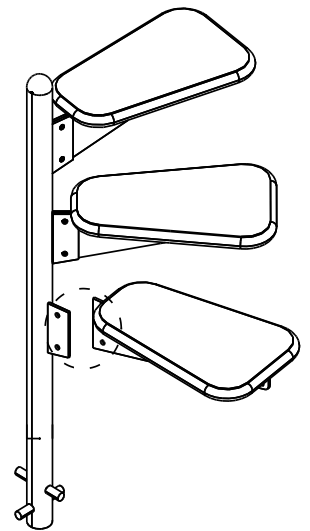

Installer's Reference



Me and My Pal Bench

Models BAR70080 and BAR70080S

Know What's Below

As with all projects involving digging, start by knowing what is in the ground below. Underground utilities may include cable, electric, sprinklers, sewer, water, telecommunications, drainage pipes and sprinklers. You can usually accomplish this with one phone call (Dial 811) to your state's underground utility service.

Conduct an Inventory

Begin installation with of hardware and parts, assuring everything you need is onsite when you begin.