

SEE DETAILS 3 & 4 FOR ANCHORING OPTIONS

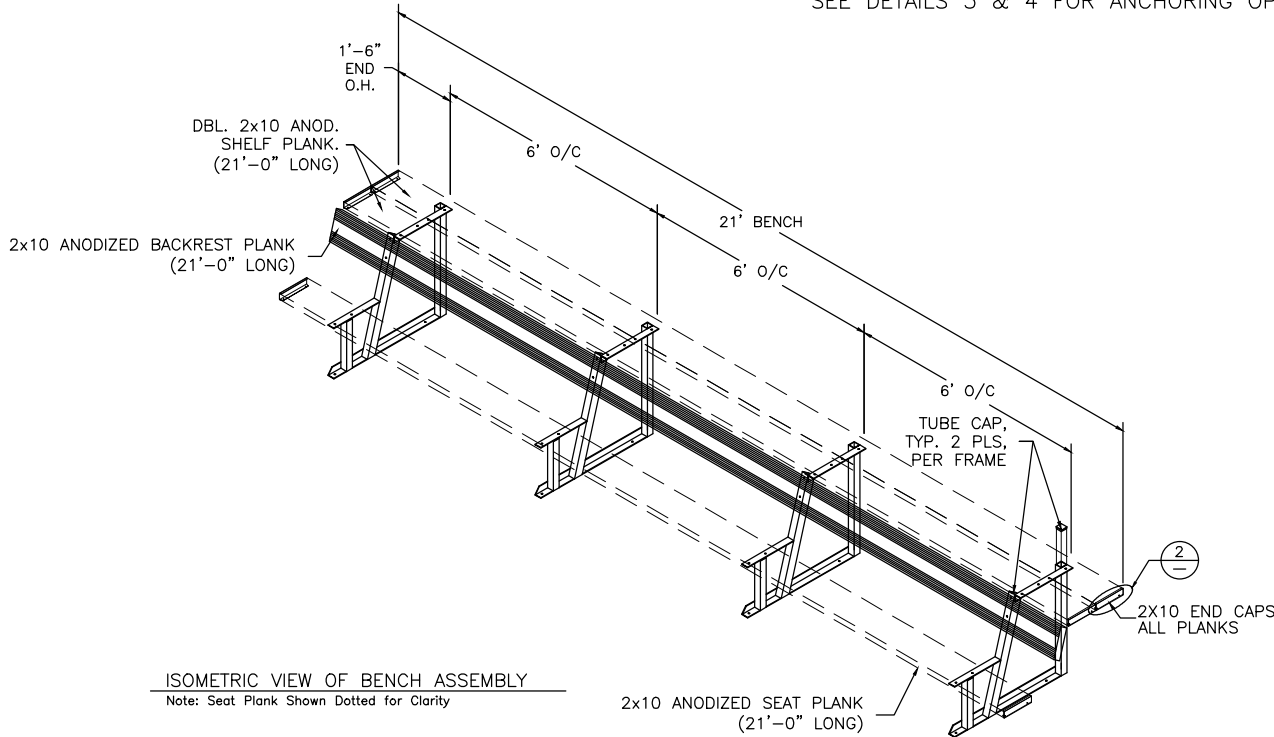

ISOMETRIC VIEW OF BENCH ASSEMBLY
 Note: Seat Plank Shown Dotted for Clarity

③ TYP 2x10 PLANK ATTACHMENT

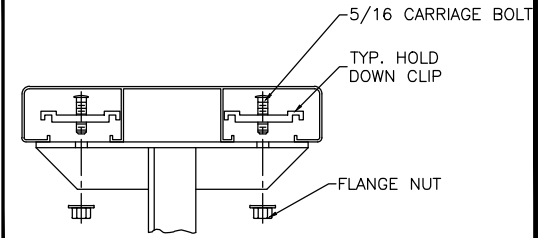

NOT TO SCALE

③ TYP 2x10 ENDCAP ATTACHMENT

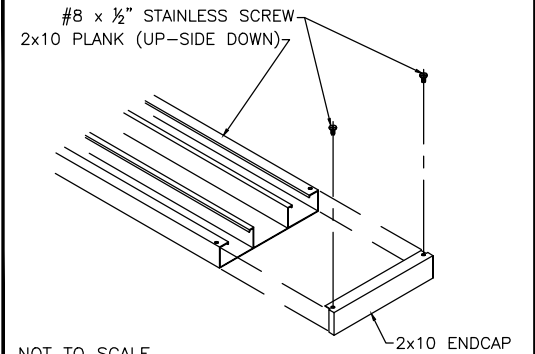

NOT TO SCALE

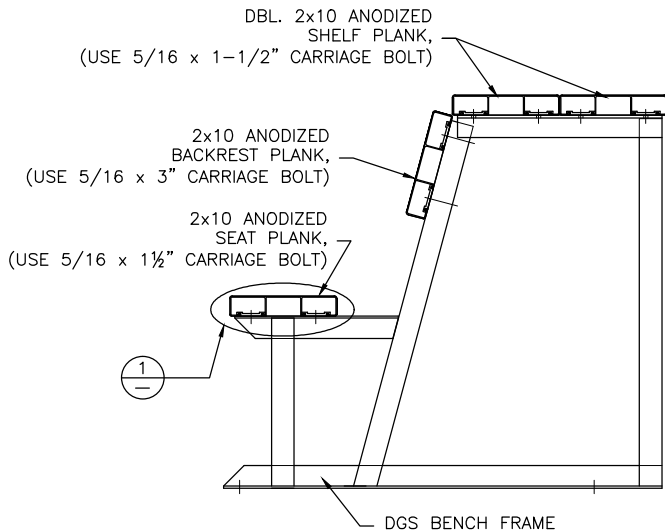

SIDE VIEW OF BENCH ASSEMBLY

④ TYP ANCHORING DETAIL

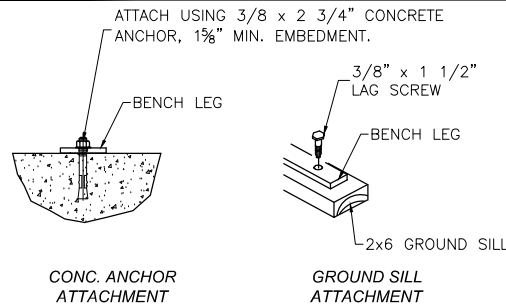

NOT TO SCALE

④ RUBBER FOOT PAD ATTACH. DETAIL

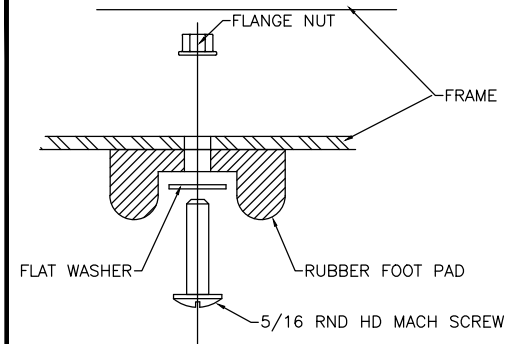

SCALE:	APPROVED BY:	DRAWN BY:
DATE:		
TITLE:		
CUSTOMER:	DRAWING NUMBER:	