

# WallGuard High Impact Corner Wall Padding

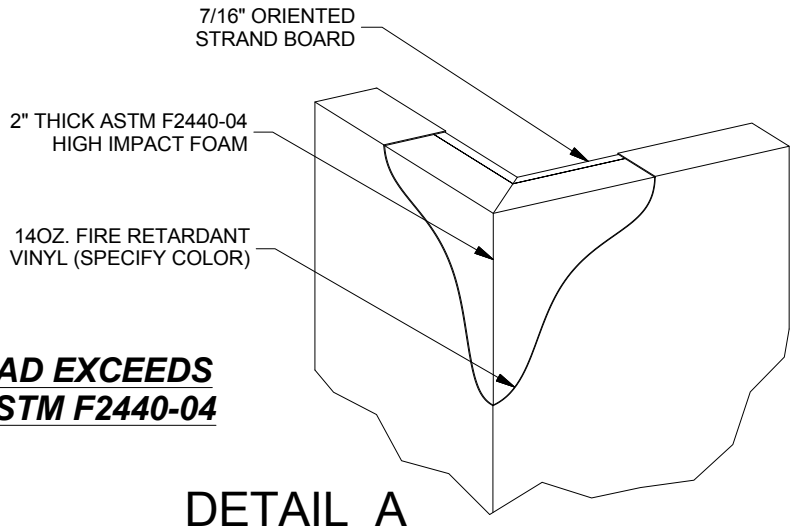
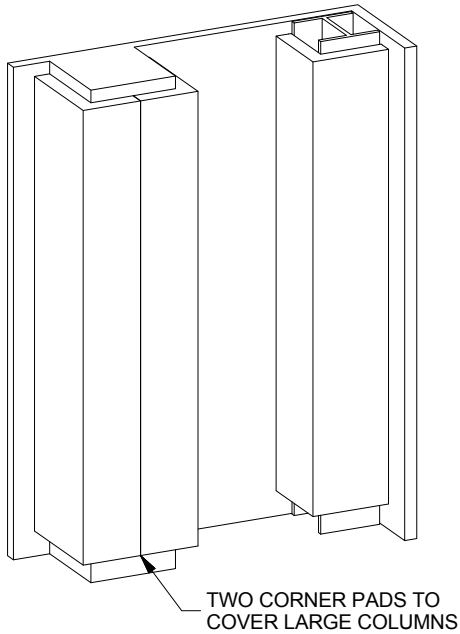

## **SPECIFICATIONS - HIGH IMPACT CORNER PADS**

WallGuard High Impact Corner Pads are for indoor use only. Vinyl meets or exceeds the requirements of NFPA 101 Life Safety Code for Class A rating (Flame Spread 0-25, Smoke Development 0-450) and California State (CSFM) test requirements. **Pad meets or exceeds impact standards as defined in ASTM F2440-04.**

Construction: Pad shall have 2" thick ASTM F2440-04 high impact foam with 7/16" oriented strand board (OSB) backing. Vinyl shall be wrapped around backside of backer board and secured with steel staples. Vinyl shall be 14 oz per square yard with grab tensile strength 365lbs x 348lbs and tongue tear strength 92lbs x 83lbs. Vinyl shall be washable and resistant to fade, rot, mildew, and fungus.

Attachment: Corner pads available with z-clip top and bottom, z-clip top and 1" margin bottom, or 1" margin top and bottom. Corner pads can be mounted to wood, drywall, concrete, brick, etc using the appropriate fasteners supplied by others.

Custom corner pad sizes are available. See additional specification for flat wall pads, straight column pads, and tapered column pads. Vinyl available in 14 standard colors.

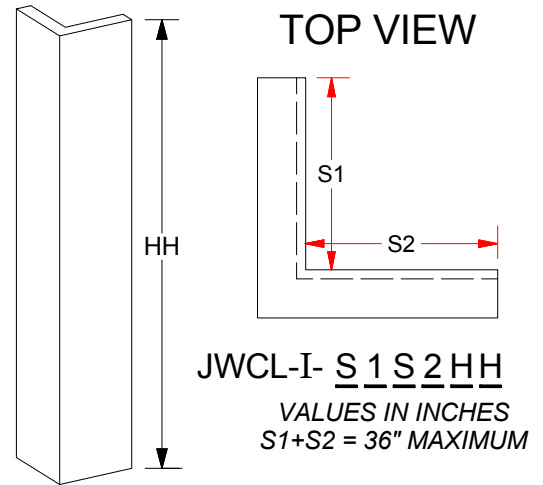

QUANTITY	P/N	DESCRIPTION
_____	JWCL-I- _____ ZZ	Z-CLIP TOP & BOTTOM
_____	JWCL-I- _____ Z	Z-CLIP TOP, 1" LIP BOTTOM
_____	JWCL-I- _____	1" LIP TOP & BOTTOM

### **SPECIFY COLOR**

- |                                       |                                 |
|---------------------------------------|---------------------------------|
| <input type="checkbox"/> ROYAL BLUE   | <input type="checkbox"/> PURPLE |
| <input type="checkbox"/> NAVY BLUE    | <input type="checkbox"/> RED    |
| <input type="checkbox"/> LIGHT BLUE   | <input type="checkbox"/> MAROON |
| <input type="checkbox"/> FOREST GREEN | <input type="checkbox"/> ORANGE |
| <input type="checkbox"/> KELLY GREEN  | <input type="checkbox"/> YELLOW |
| <input type="checkbox"/> BLACK        | <input type="checkbox"/> TAN    |
| <input type="checkbox"/> WHITE        | <input type="checkbox"/> GRAY   |

PROJECT NAME \_\_\_\_\_

PROJECT NUMBER \_\_\_\_\_

ARCHITECT \_\_\_\_\_

CONTRACTOR \_\_\_\_\_

NOTES \_\_\_\_\_

**TERRA BOUND**  
SOLUTIONS™

**WallGuard**  
Impact Wall Padding

www.terraboundsolutions.com  
1-877-857-2915  
20020 Hickory Twig Way  
Spring, TX 77388