

TERRA BOUND
SOLUTIONS™



4" Speed Bump

Without the need to bolt down these speed bumps, one of the most aggressive traffic calming products on the market today can be temporarily deployed and easily recovered whenever and wherever you need them. The unique design of these speed bumps means that they will stay in place without the use of spikes, lag bolts, and/or adhesives. Simply put them down and link them together! The 4" Speed Bump provides you with 4" of solid, 100% recycled, masticated rubber which is manufactured to withstand extreme temperatures, constant UV light, extreme weather conditions, and of course, high traffic volume. Not recommended for pedestrian use, normal vehicle use not recommended.



Designed to slow traffic to a crawl of 3-5 mph, the 4" Speed Bump has been repeatedly field-tested to take the abuse and compression of extremely high-weight vehicles, including fully-loaded, 74,000 lb tractor-trailers. The 4" Speed Bump comes with a high visibility, yellow reflective stripe for use during low-light or night-time conditions.

Three units are easily deployed to cover a 9 foot wide traffic lane. More units give you unlimited length and coverage. Designed for extremely height weight vehicles.

Features:

- 100% Recycled Whole Tire Rubber
- Portable or Permanent - unlimited connectivity
- Slow-down traffic during fire and auto accident emergencies
- Multitude of configurations
- 3ft long per bump
- Galvanized lag bolt and anchors for permanent installation
- High visibility safety yellow paint
- Target slow down speed from 3 to 5 mph
- Patented
- Made in U.S.A.



**100% Recycled
Material**



UV Resistant



**Made in the
USA**



**LEED
Certified**

4" Speed Bump Specifications

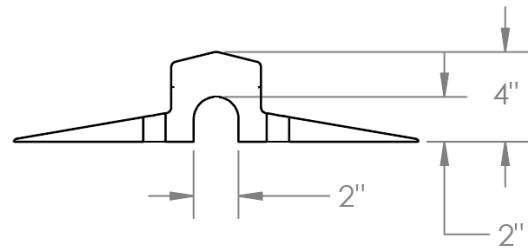
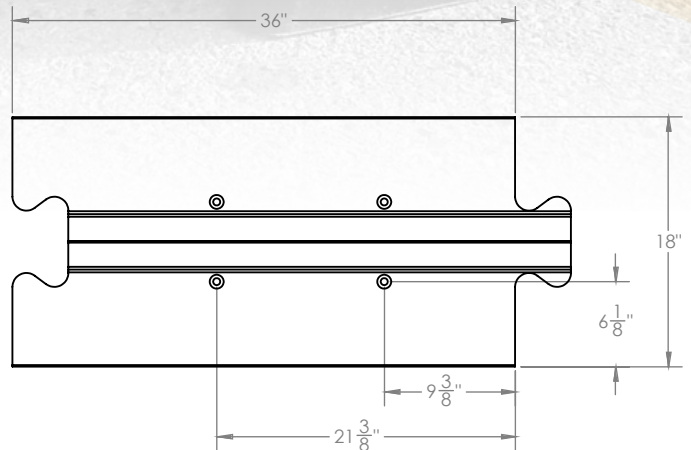

Specifications:

- 43 lbs
- 4"H x 18"W x 36"L
- Masticated recycled whole tire rubber
- Yellow reflective strip on both sides
- Available with or without cable hole

Models:

RF-MLSB4

- RubberForm 4"High Speed Bump

Hardware:

RF - MLSBHW

- 4 Bolts
- 4 Anchor Sleeves
- 4 Washers (1/2"W x 5"L)
- Adhesive

