

Attach Rover Jump  
Over Panel and Rover  
Jump Over Support  
Panel to Rover  
Support Post using  
specified hardware.

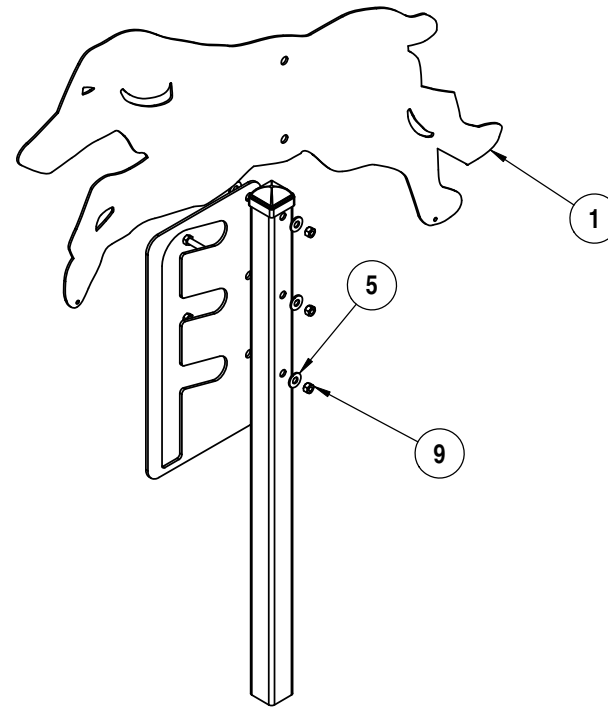

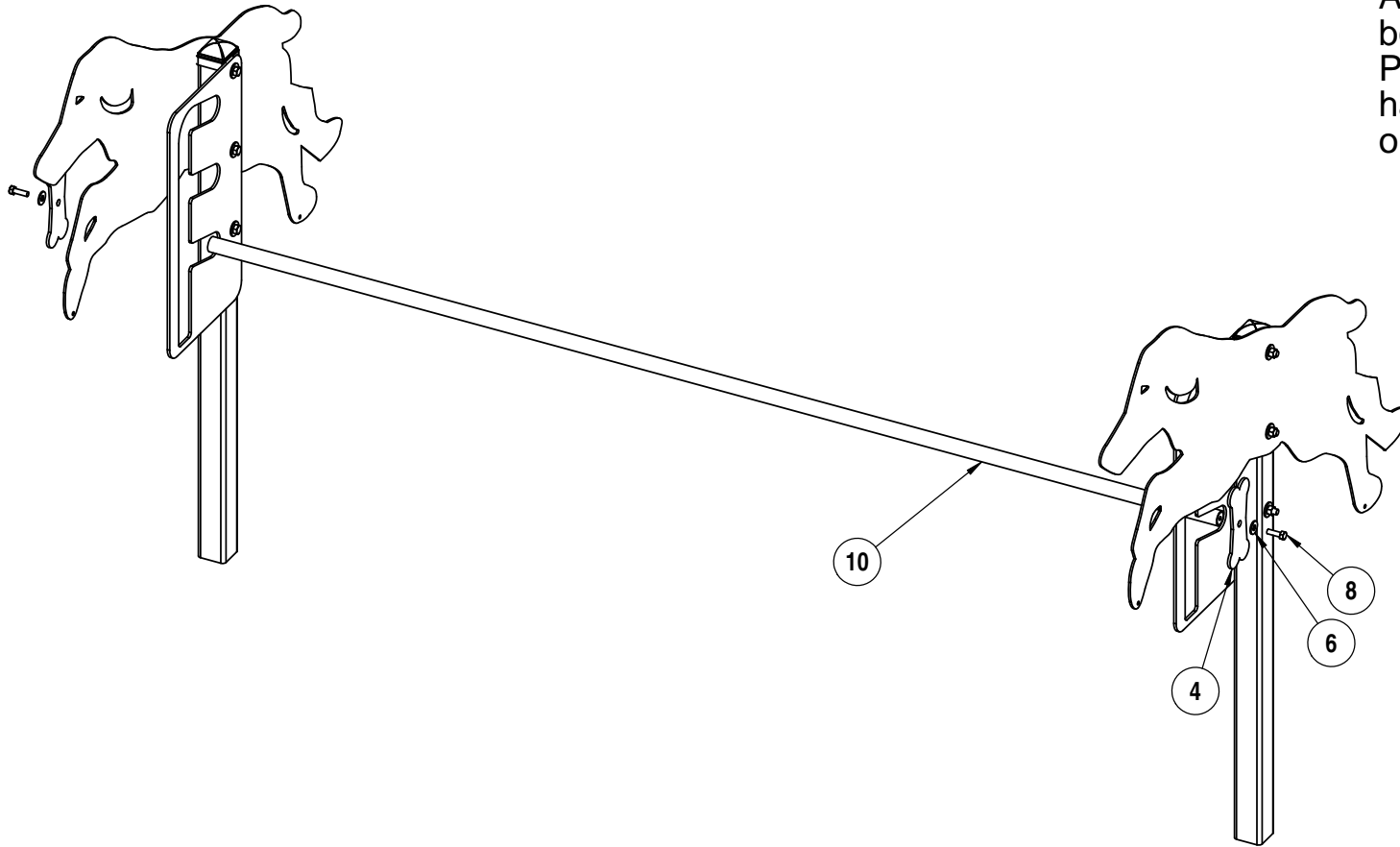

Pull Jump Pipe through corresponding slots in the Rover Jump Over Support Panel, then attach Bone Attachment Plates to both ends of the Jump Pipe using specified hardware. Use Loctite on these bolts.

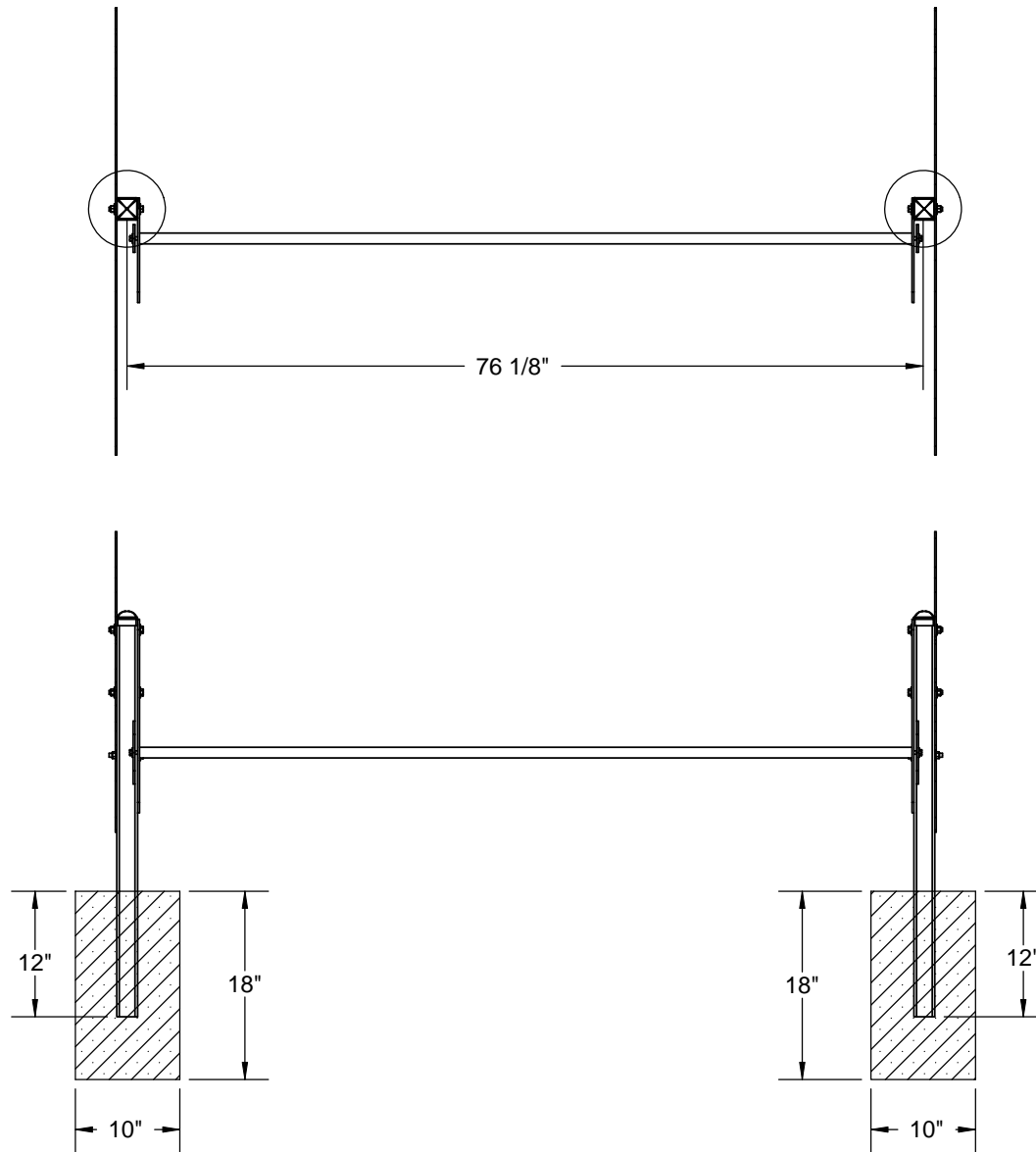

Estimated Required Concrete:  
5 - 50 lb. bags of concrete mix

OVERALL DIMENTIONS

