

8 Foot Landmark Park Bench w/Arms

For Fastener Pack
(FP-LB8BA-CU-02)

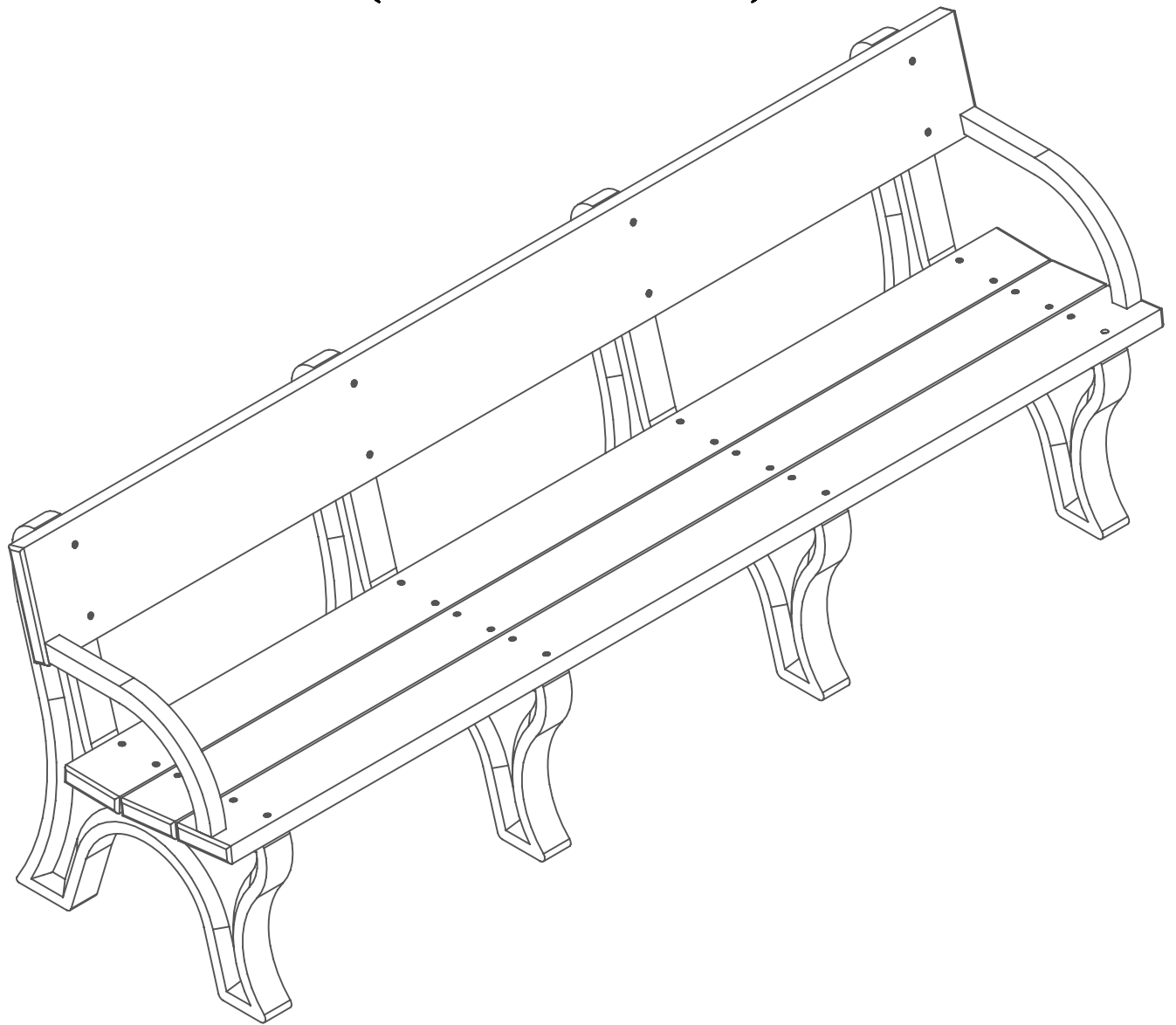

Congratulations !!

You have just purchased the finest recycled plastic
park bench available. Enjoy !!!

Before assembly, please make sure all components are included.



FP - Fastener Pack

(1) - One Fastener Pack
FP-LB8BA-CU-02

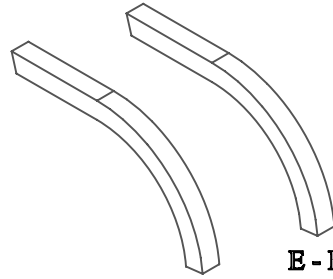

(2) - Two Bench Arms
BP-BA-A-01

E - Bench Arm
E - Bench Arm

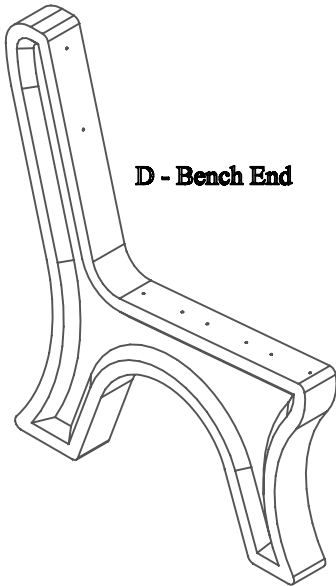

D - Bench End

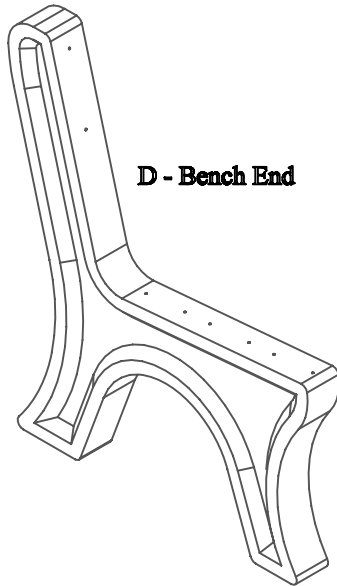

D - Bench End

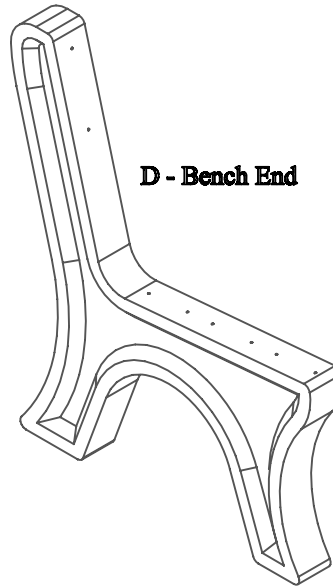

D - Bench End

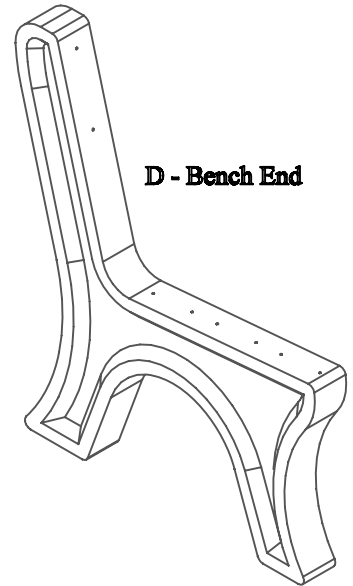

D - Bench End

(4) - Four Bench Ends
PS-SBBE-L-02



A - Back Bench Board w/ Arm holes

(1) - One Back Bench Board w/ Arm holes
BP-LB8BA-A-01

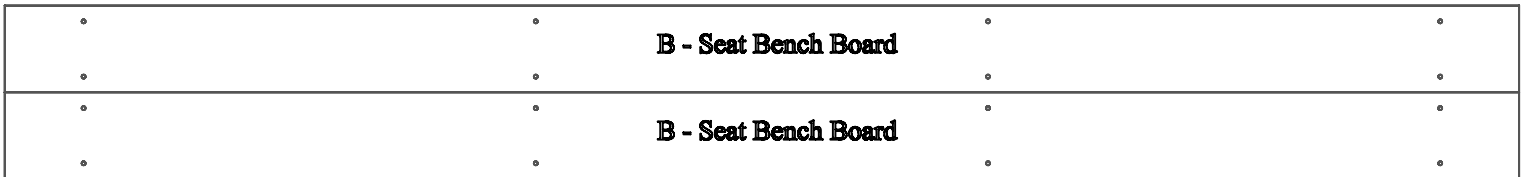

B - Seat Bench Board

B - Seat Bench Board

(2) - Two Seat Bench Boards
BP-TB8B-A-02



C - Seat Bench Board w/ Arm holes

(1) - One Seat Bench Boards w/ Arm holes
BP-TB8BA-A-02

Before assembly, please make sure all fasteners are included.

36 #12 x 3" Flat Head Phillips Screw



Also needed for this assembly will be the following materials:

1 - #3 Phillips Drive Bit

Fig #1:

In order to make the assembly of this Landmark Bench easier while going through the assembly process the board positions are numbered and will be referenced in later steps.

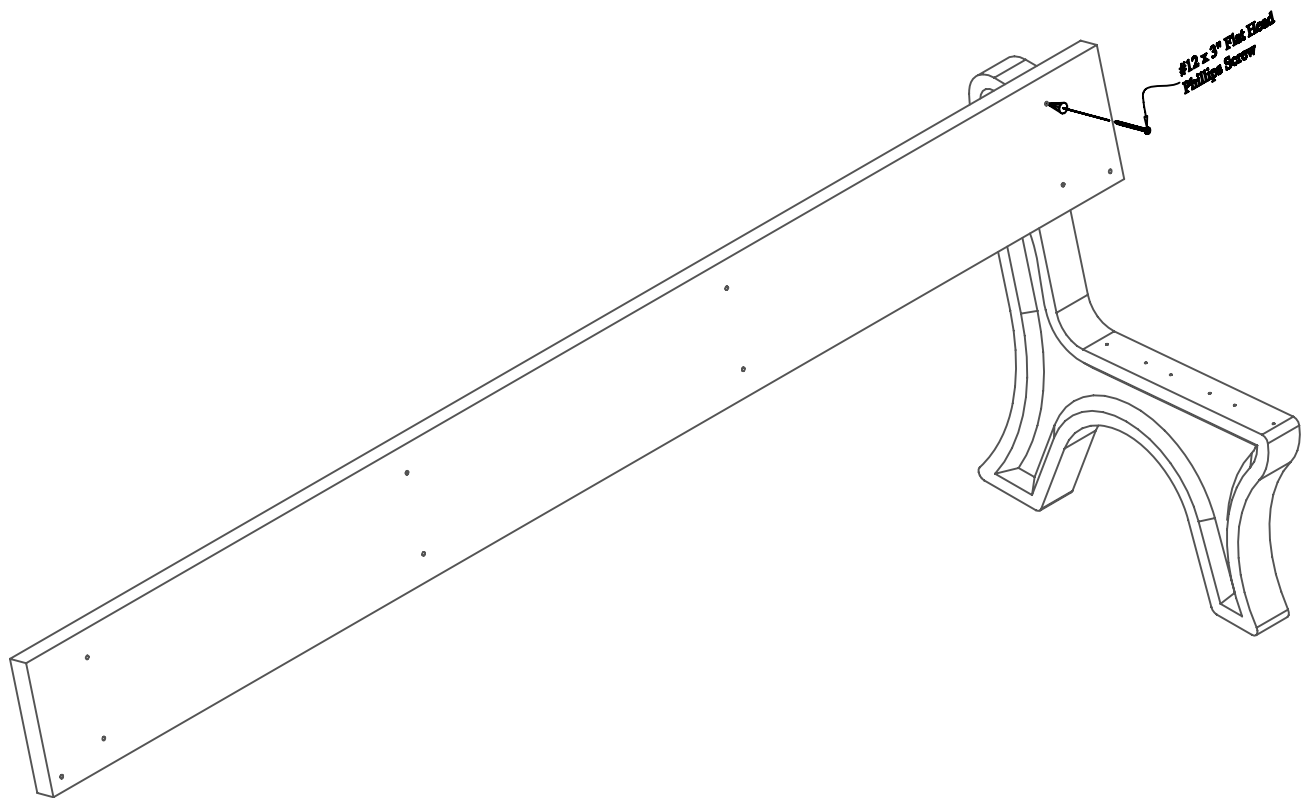
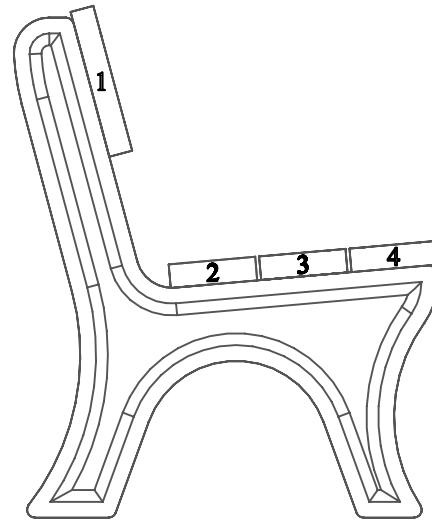

Step #1:

Stand (1) One bench end upright and place (1) One back bench board w/ Arm holes on position 1 being sure to align the pre-drilled holes to the pilot holes in the bench end. After the holes are properly aligned, fasten with (1) One #12 x 3" Flat Head Phillips Screw in the top pre-drilled hole of the back bench board.

Note: Do not tighten screw completely. This will be done in a later step.

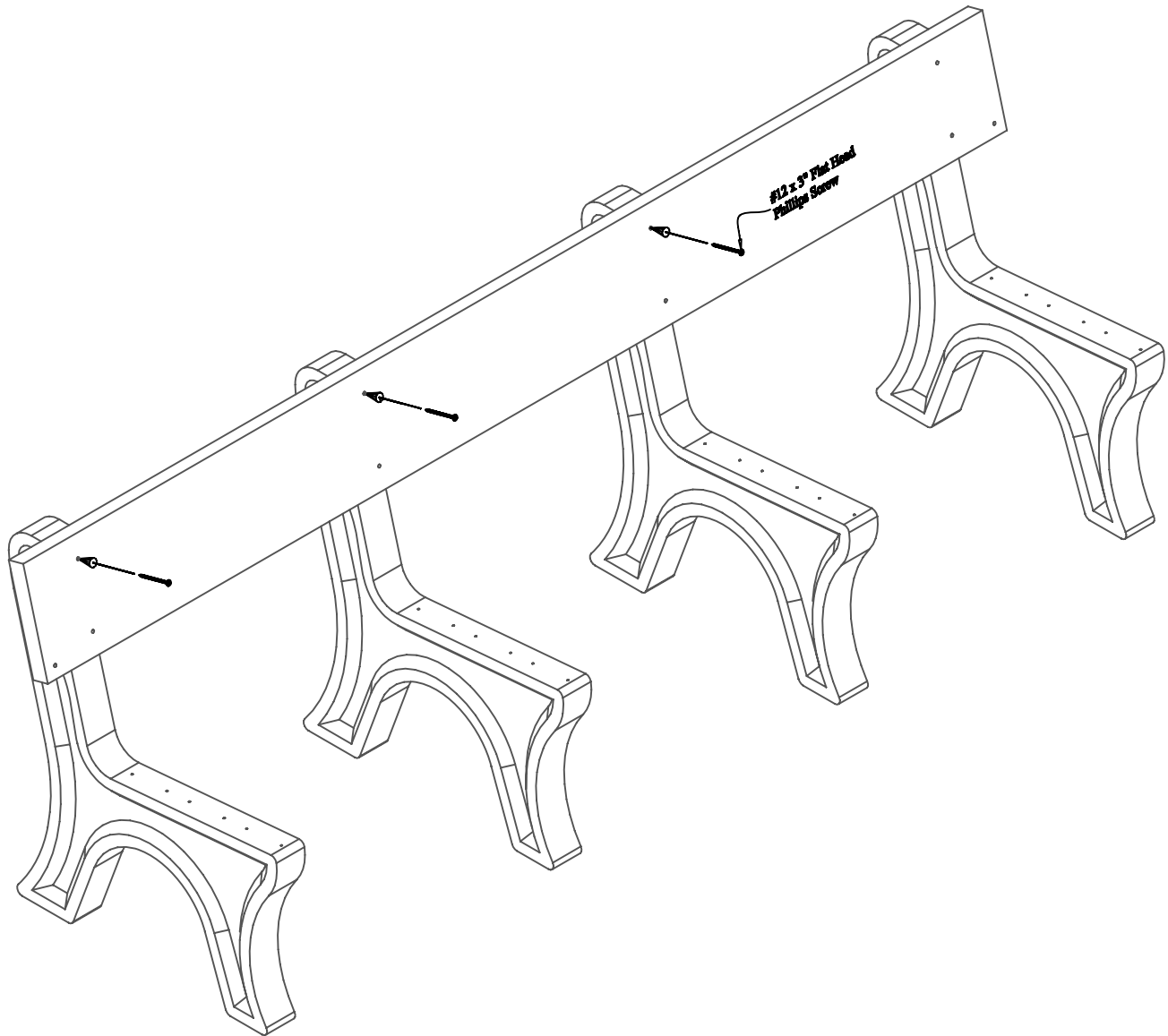

Step #2:

Stand the other (3) Three bench ends upright, one at a time, and place the back bench board w/ Arm holes already attached to the first bench end, on position 1 being sure to align the pre-drilled holes with the pilot holes in the bench end. After the holes are properly aligned, fasten with (1) One #12 x 3" Flat Head Phillips Screw in the top pre-drilled hole of the back bench board.

Note: Do not tighten screws completely. This will be done in a later step.

Step #3:

Align the bottom pre-drilled holes on the back bench board w/ Arm holes to the pilot holes on the bench end. After the holes are properly aligned, fasten with (1) One #12 x 3" Flat Head Phillips Screw per hole.

Note: Be sure to tighten screws completely after this step.

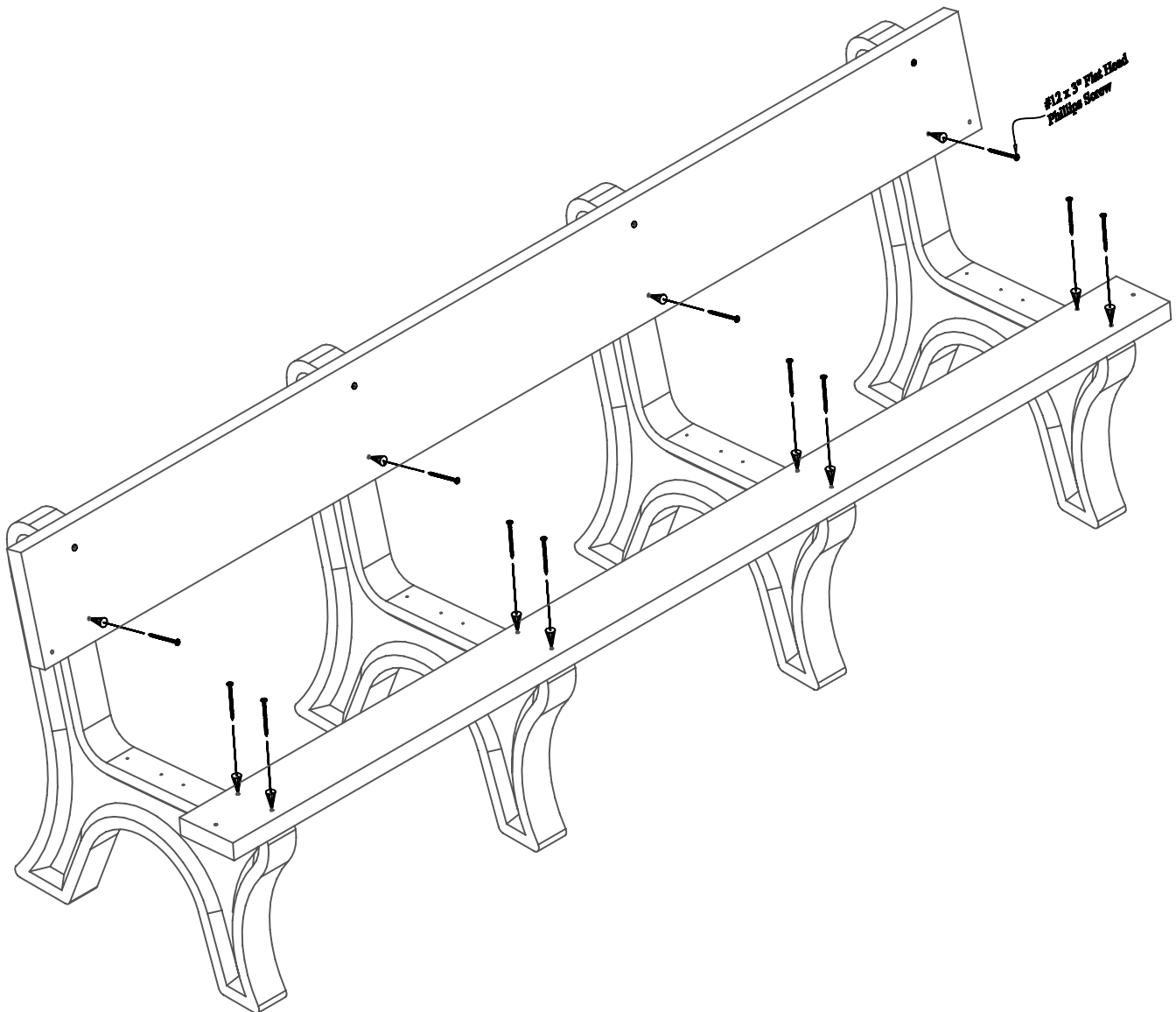

Step #4:

Place (1) One seat bench board w/ Arm holes on position 4. Repeat Steps 1 - 3 to attach. Use (1) One #12 x 3" Flat Head Phillips Screw per hole to fasten.

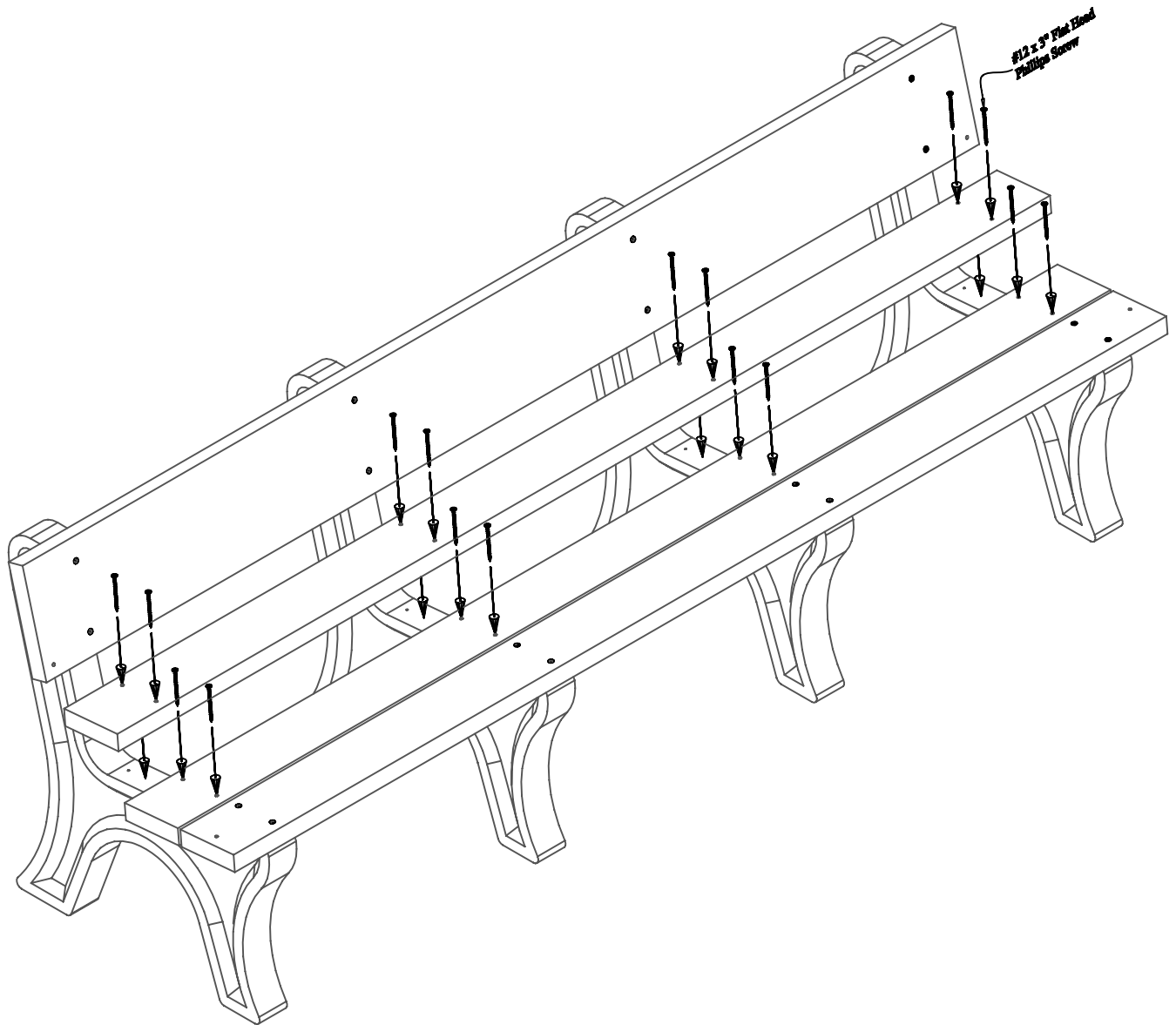

Step #5:

Repeat Steps 1 - 3 to attach seat bench boards on positions 2 & 3. Use (1) One #12 x 3" Flat Head Phillips Screw per hole to fasten.

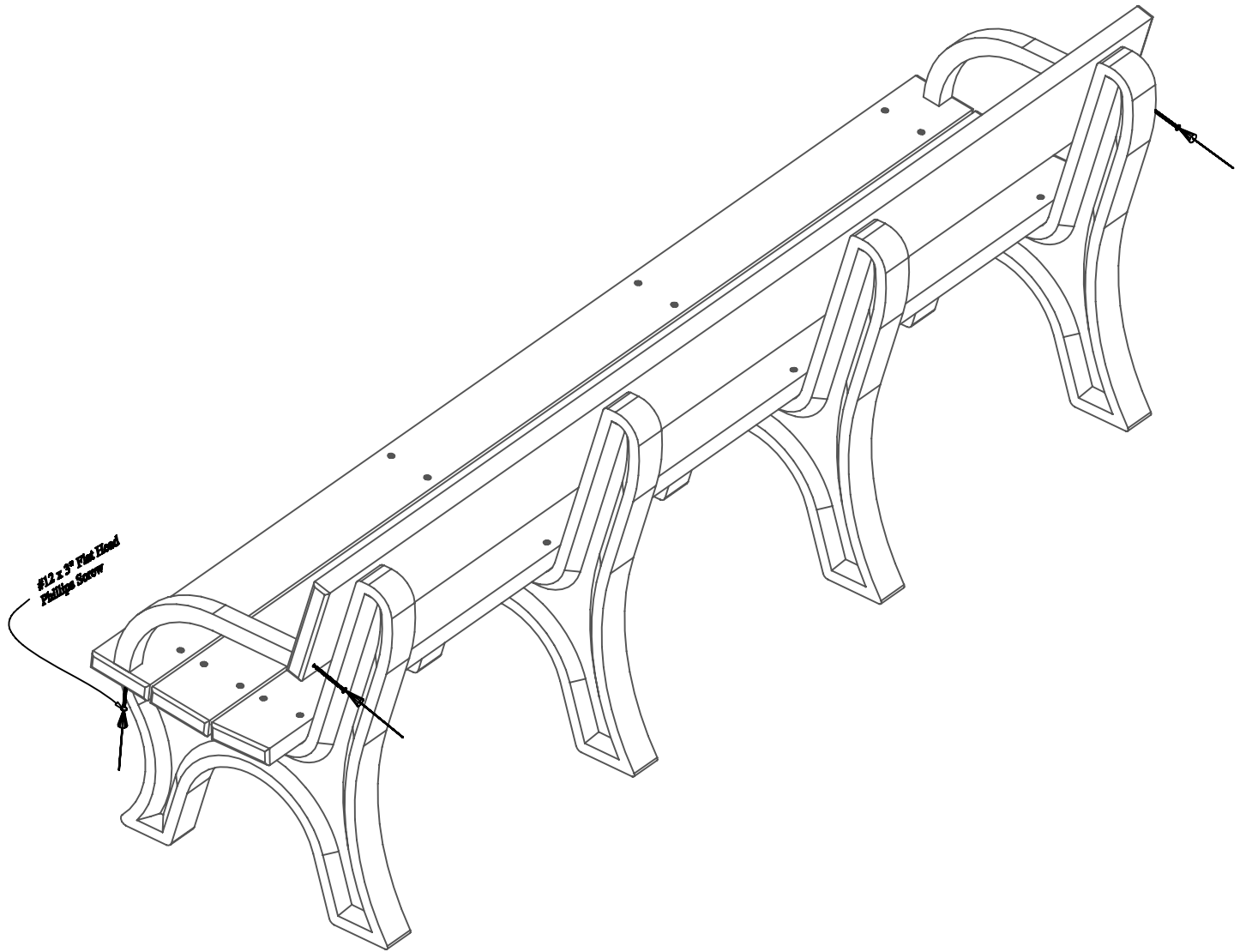

Step #6:

Align the pilot holes on the Arm to the pre-drilled holes on the bench boards w/ arm holes. After the holes are properly aligned, fasten with (1) One #12 x 3" Phillips head screw per hole to fasten.