

8 Foot Econo-mizer Park Bench w/ Arms

For Fastener Pack
(FP-EM8BA-CU-02)

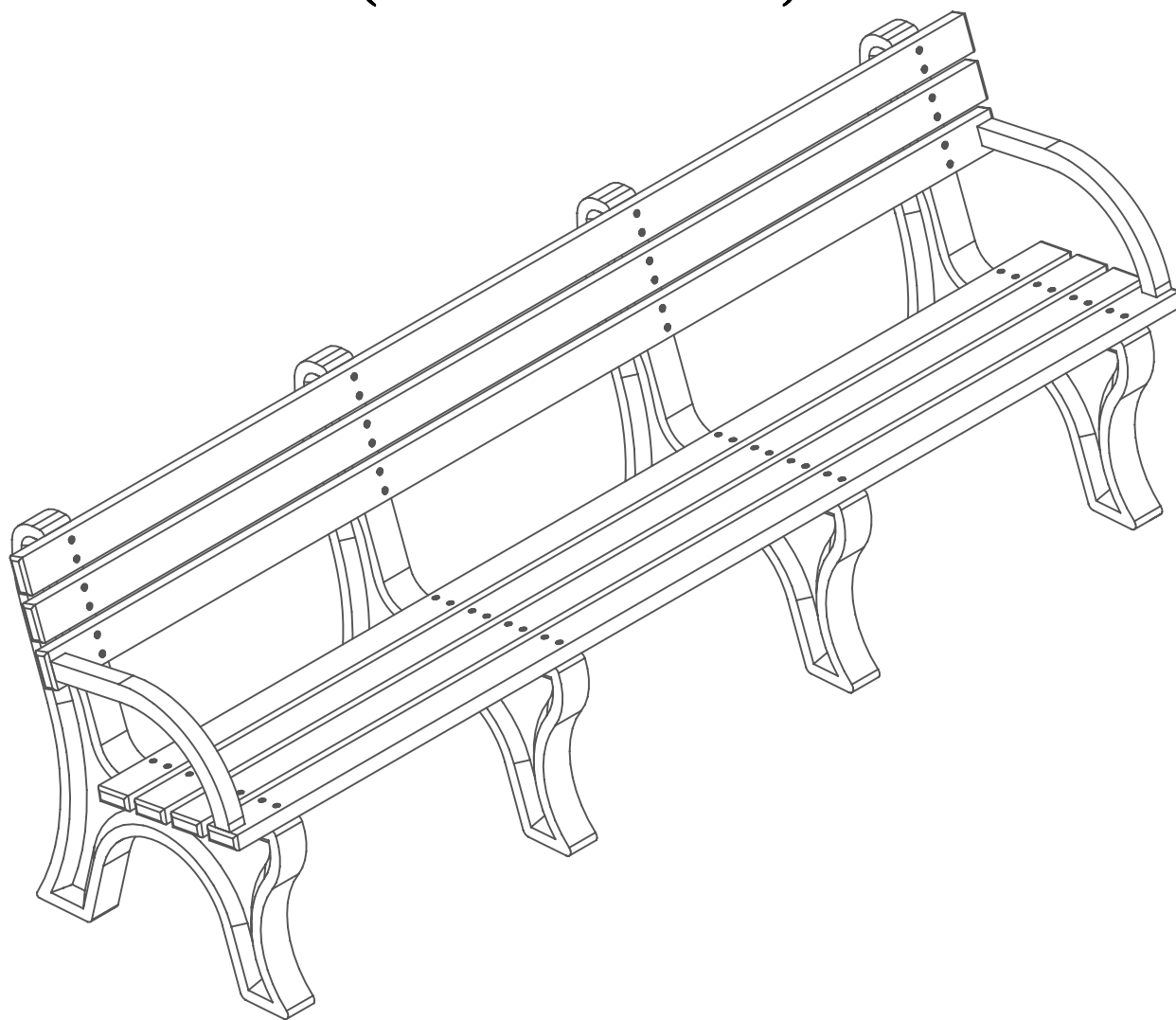

Congratulations !!

You have just purchased the finest recycled plastic
park bench available. Enjoy !!!

Before assembly, please make sure all components are included.



(1) - One Fastener Pack
FP-EM8BA-CU-01

FP - Fastener Pack

(2) - Two Bench Arms
BP-BA-A-01

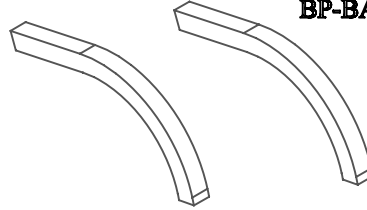

(D) - Bench Arm (D) - Bench Arm

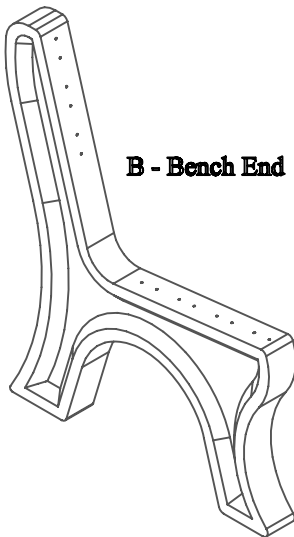

B - Bench End

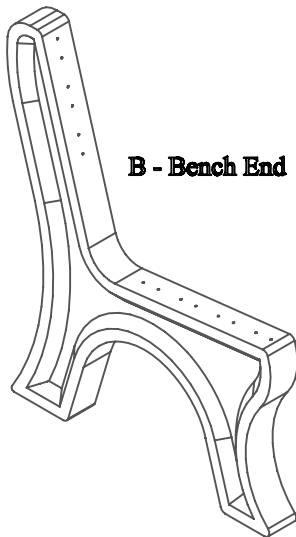

B - Bench End

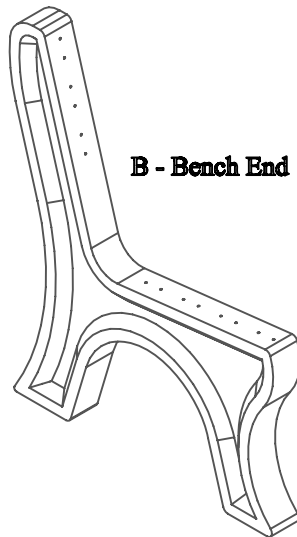

B - Bench End

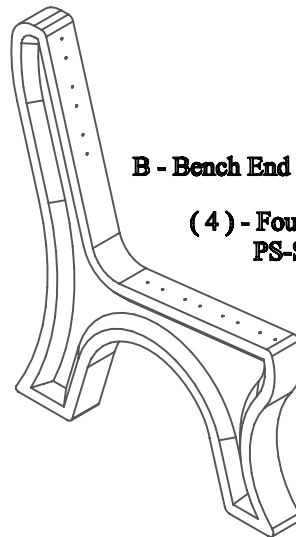

B - Bench End

(4) - Four Bench Ends
PS-SBBE-D-01

•	•	A - Bench Board	•	•
•	•	A - Bench Board	•	•
•	•	A - Bench Board	•	•
•	•	A - Bench Board	•	•
•	•	A - Bench Board	•	•

(5) Five Bench Boards
BP-DB8B-A-01

•	•	C - Bench Board w/Arm holes	•	•
•	•	C - Bench Board w/Arm holes	•	•

(2) Two Bench Boards w/Arm holes
BP-DB8BA-A-01

Before assembly, please make sure all fasteners are included.

60- #12 x 3" Flat Head Phillips Screw



Also needed for this assembly will be the following materials:

1 - #3 Phillips Drive Bit

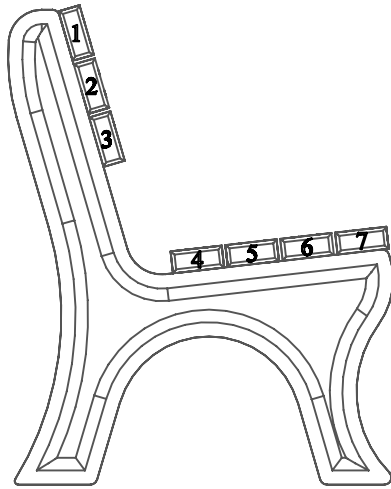
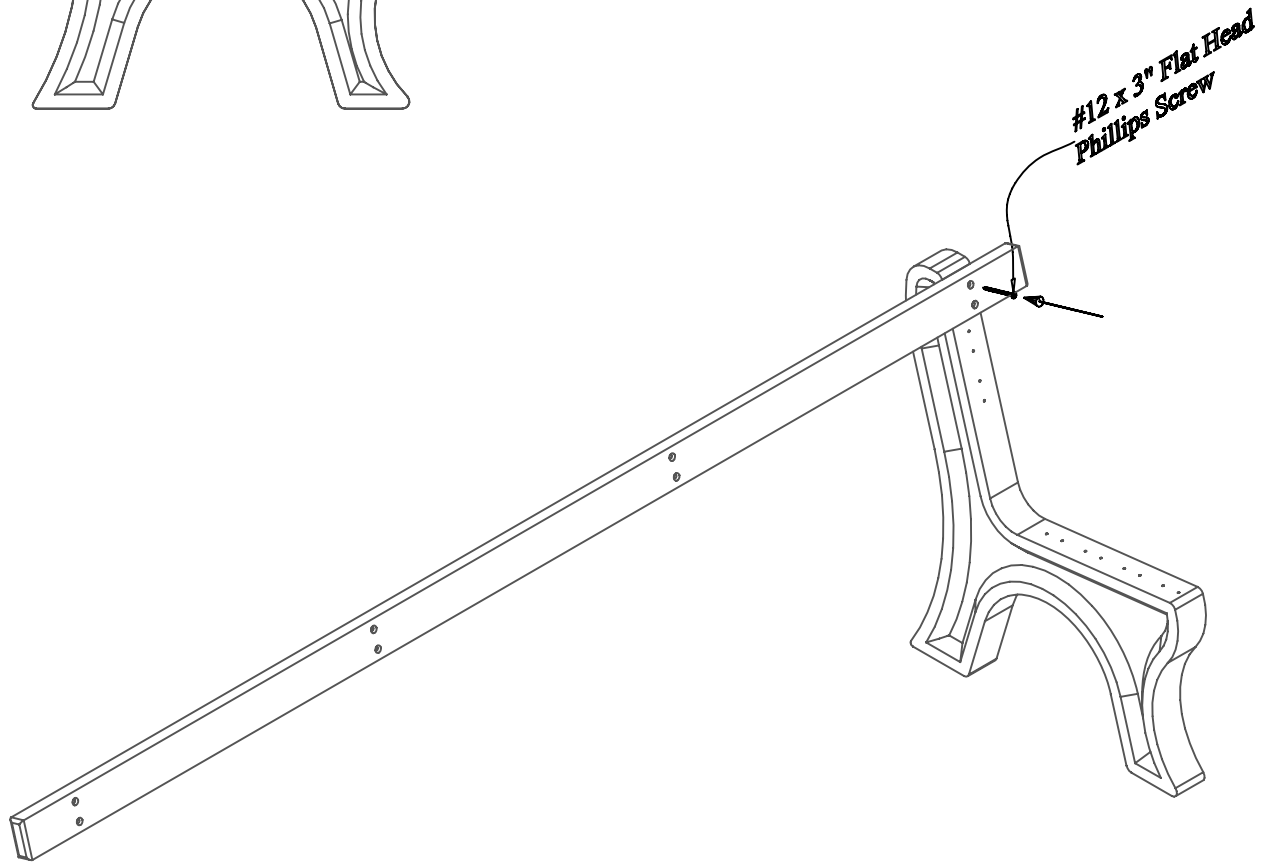

Fig #1:

In order to make the assembly of this Deluxe Bench easier while going through the assembly process the board positions are numbered and will be referenced in later steps.



Step #1:

Stand (1) One bench end upright and place (1) One bench board on position 1 being sure to align the pre-drilled holes to the pilot holes in the bench end. After the holes are properly aligned, fasten with (1) One #12 x 3" Flat Head Phillips Screw in the top pre-drilled hole.

Note: Do not tighten screw completely. This will be done in a later step.

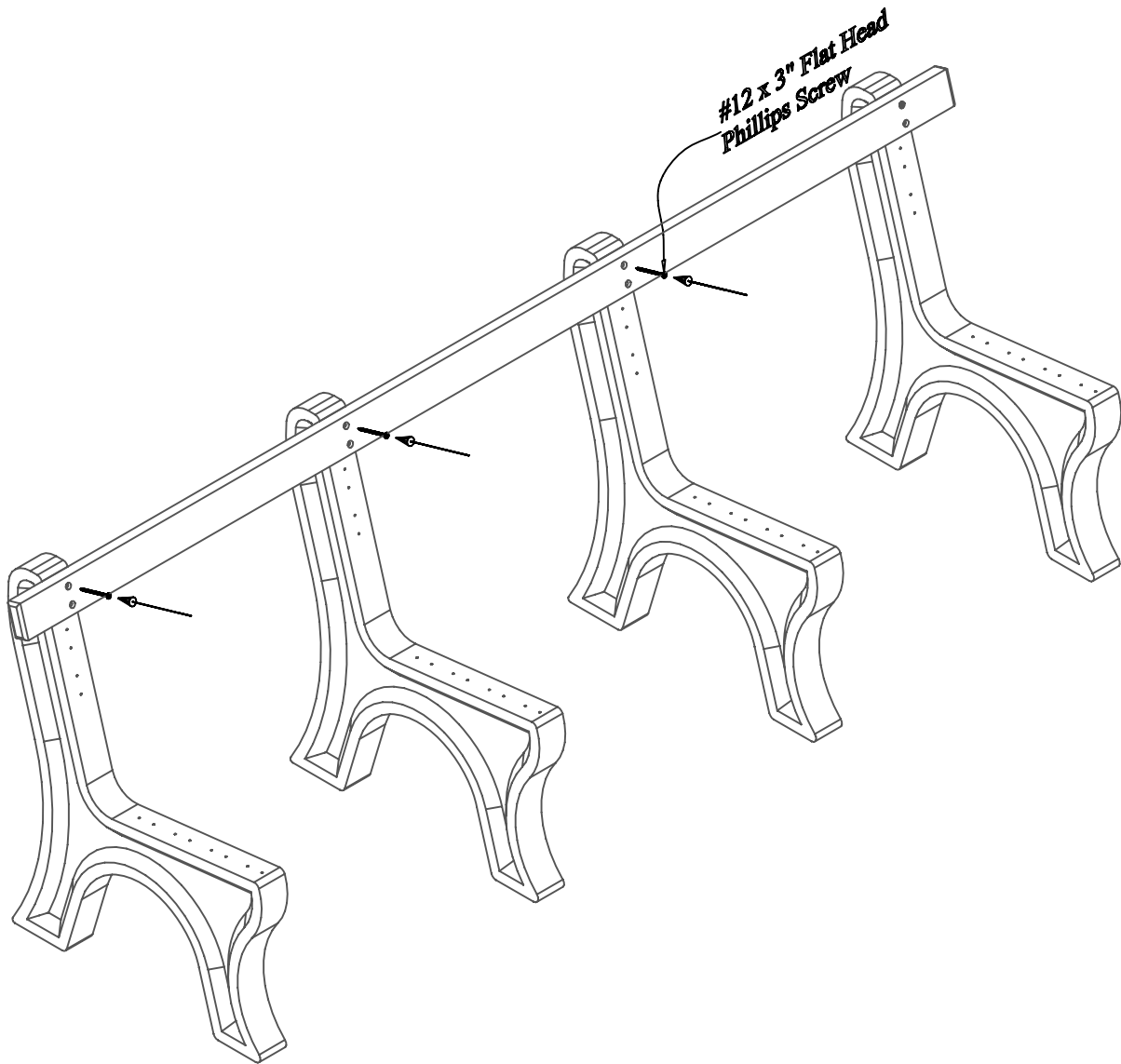

Step #2:

Stand the other (3) Three bench ends upright, one at a time, and place the bench board already attached to the first bench end, on position 1 being sure to align the pre-drilled holes to the pilot holes in the bench end. After the holes are properly aligned, fasten with (1) One #12 x 3" Flat Head Phillips Screw in the top pre-drilled hole.

Note: Do not tighten screws completely. This will be done in a later step.

Step #3:

Align the bottom pre-drilled holes to the pilot holes in the bench end. After the holes are properly aligned, fasten with (1) One #12 x 3" Flat Head Phillips Screw per hole.

Note: Be sure to tighten screws completely after this step.

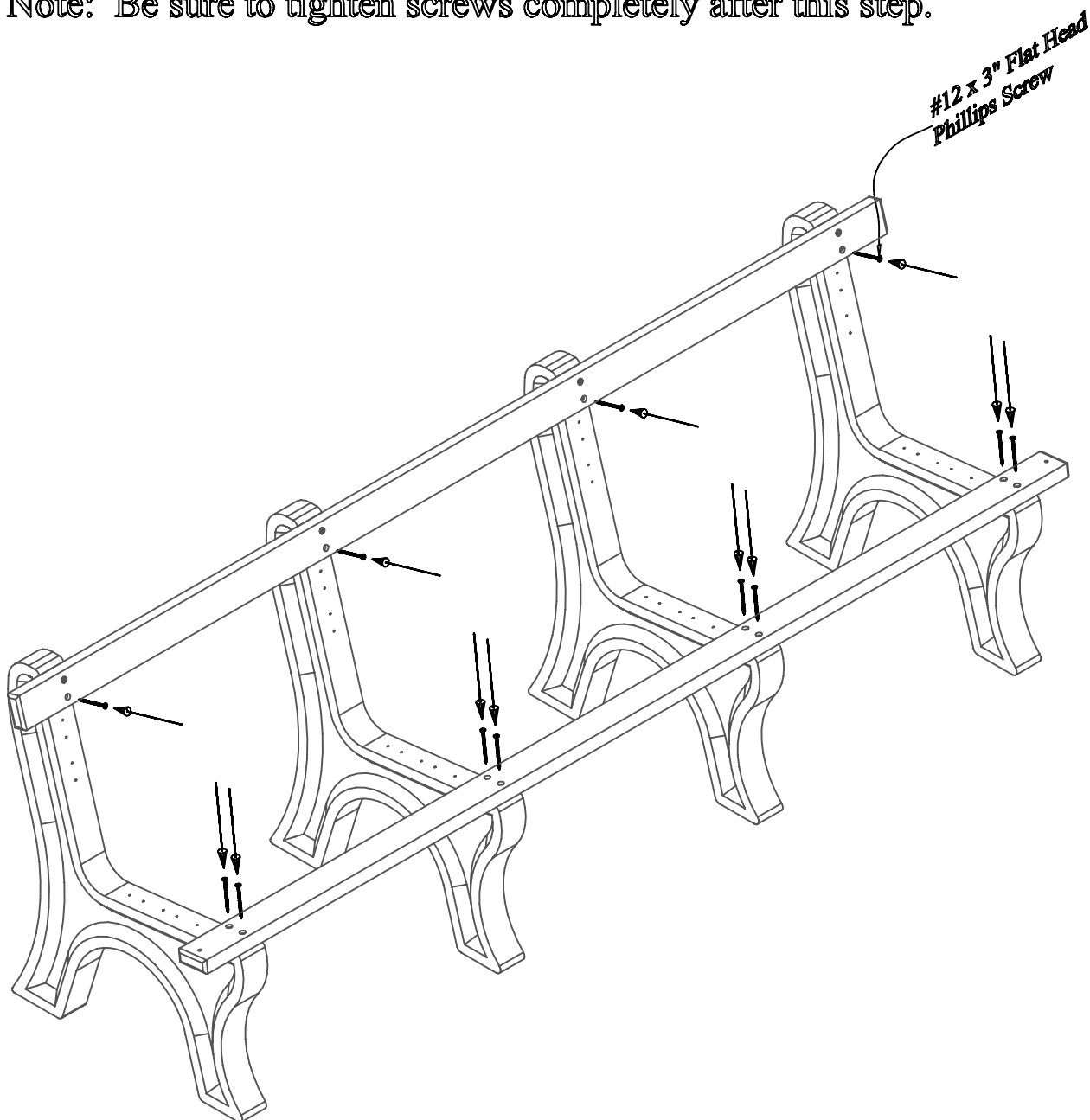

Step #4:

Place a second bench board w/ arms holes on position 7. Repeat Steps 1 - 3 to attach. Use (1) One #12 x 3" Flat Head Phillips Screw per hole to fasten.

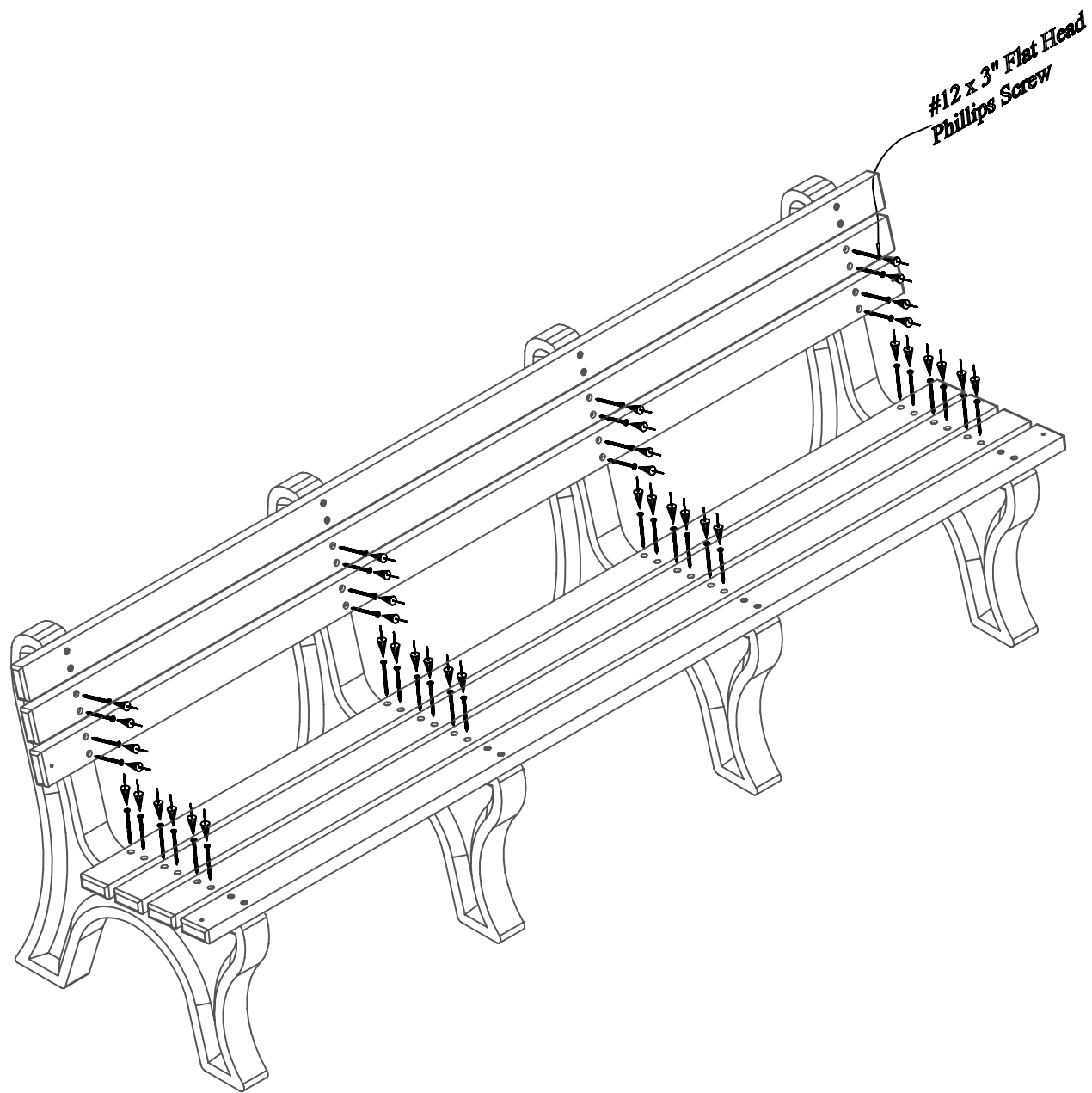

Step #5:

Repeat Steps 1 - 3 to attach bench boards on positions 2, 4, 5 & 6 and a bench w/ arm holes in position 3. Use (1) One #12 x 3" Flat Head Phillips Screw per hole to fasten.

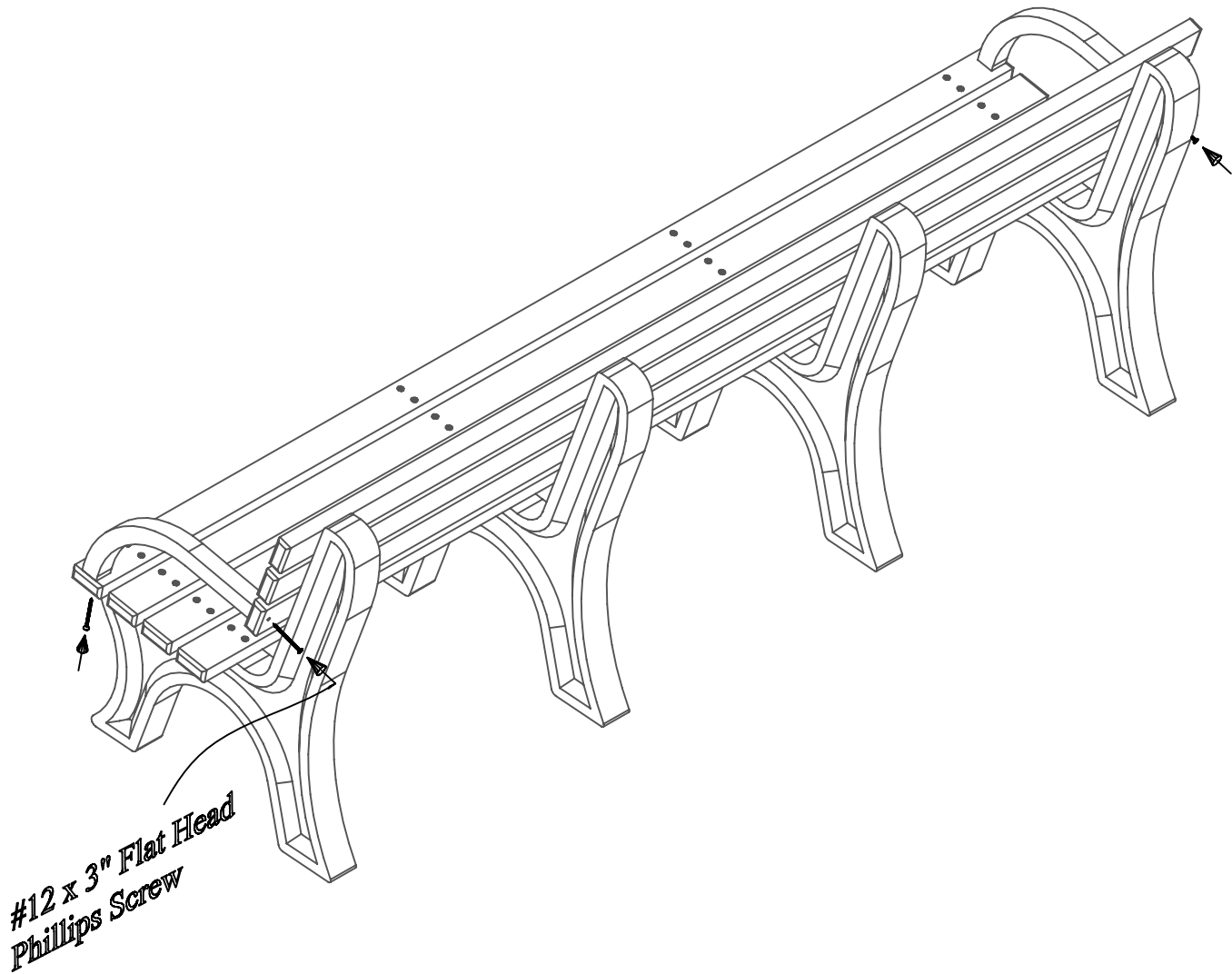

Step #6:

Position the bench arms as shown above. Align the pilot holes to the pre-drilled holes in the bench board w/ arm holes. After the holes are properly aligned, fasten with (1) One #12 x 3" Flat Head Phillips Screw per hole.