

6 Foot Econo-mizer Park Bench w/Arms

For Fastener Pack
(FP-EM6BA-CU-02)

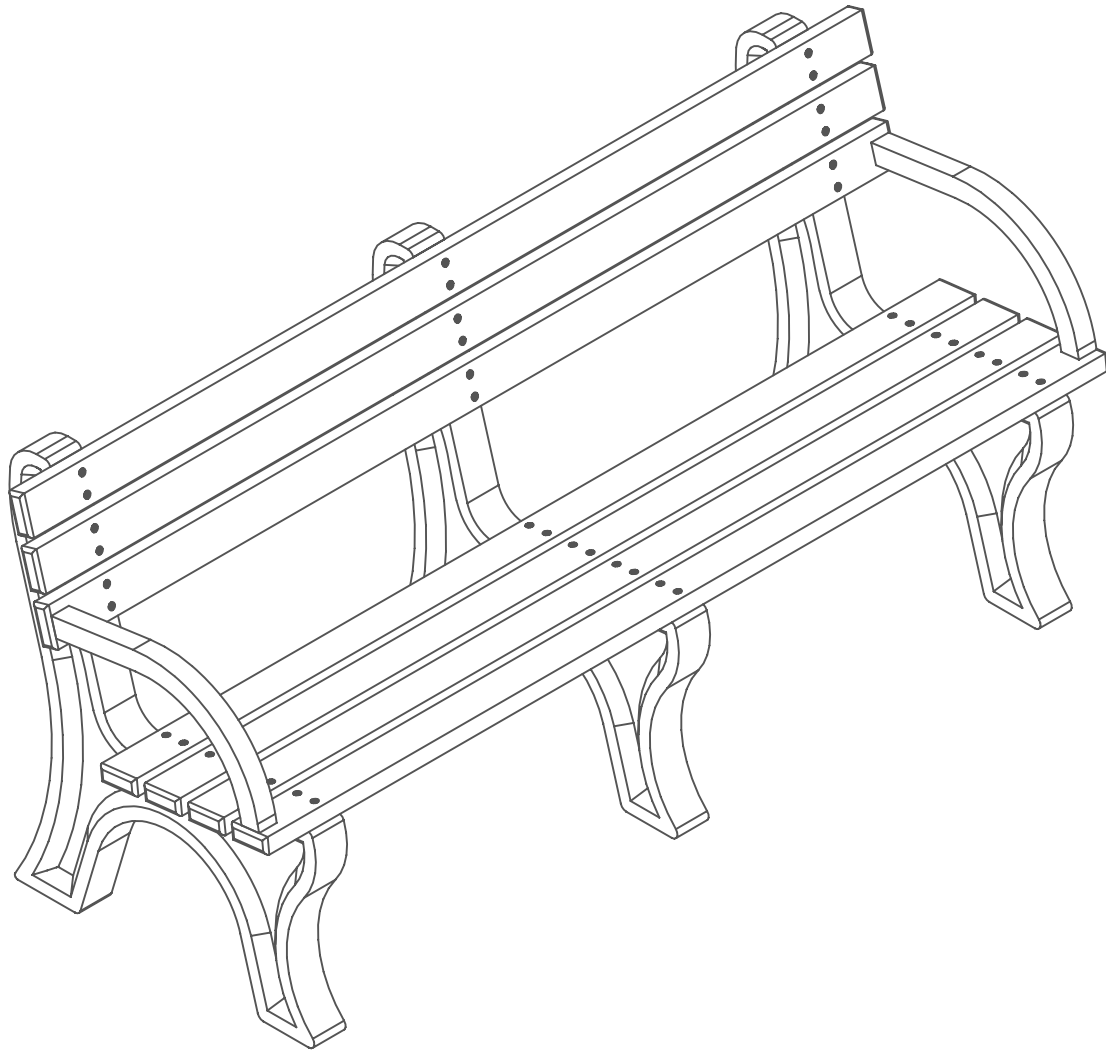

Congratulations !!

You have just purchased the finest recycled plastic
park bench available. Enjoy !!!

Before assembly, please make sure all components are included.



(1) - One Fastener Pack
FP-EM6BA-CU-01

FP - Fastener Pack

(2) - Two Bench Arms
BP-BA-A-01

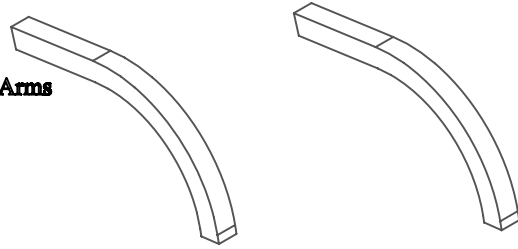

D - Bench Arm

D - Bench Arm

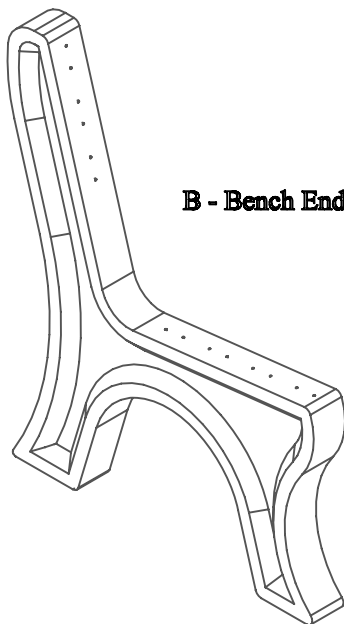

B - Bench End

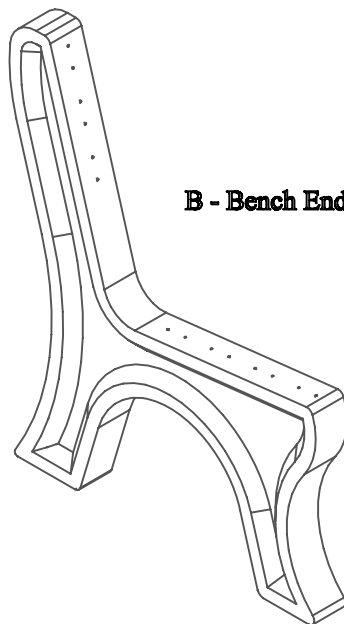

B - Bench End

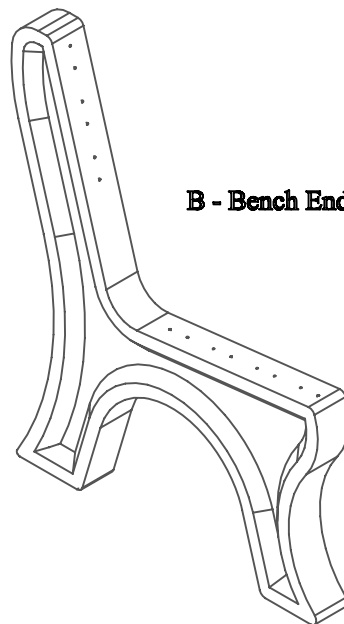

B - Bench End

(3) - Three Bench Ends
PS-SBBE-D-01

| | | |
|---|-----------------|---|
| • | A - Bench Board | • |
| • | A - Bench Board | • |
| • | A - Bench Board | • |
| • | A - Bench Board | • |
| • | A - Bench Board | • |

(5) - Five Bench Boards
BP-EM6B-A-01

| | | |
|---|-----------------------------|---|
| • | C- Bench Board w/ Arm holes | • |
| • | C- Bench Board w/ Arm holes | • |

(2) - Two Bench Boards w/ Arm holes
BP-EM6BA-01

Before assembly, please make sure all fasteners are included.

46- #12 x 3" Flat Head Phillips Screw



Also needed for this assembly will be the following materials:

1 - #3 Phillips Drive Bit

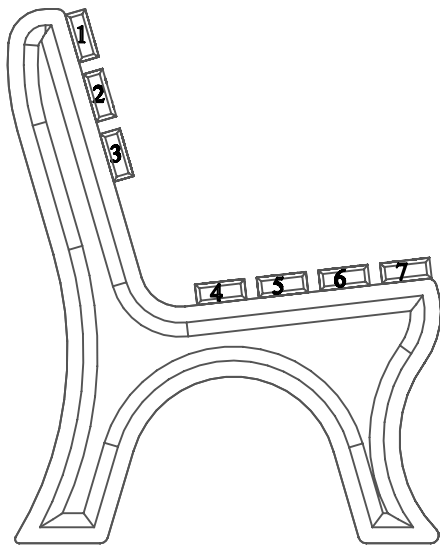
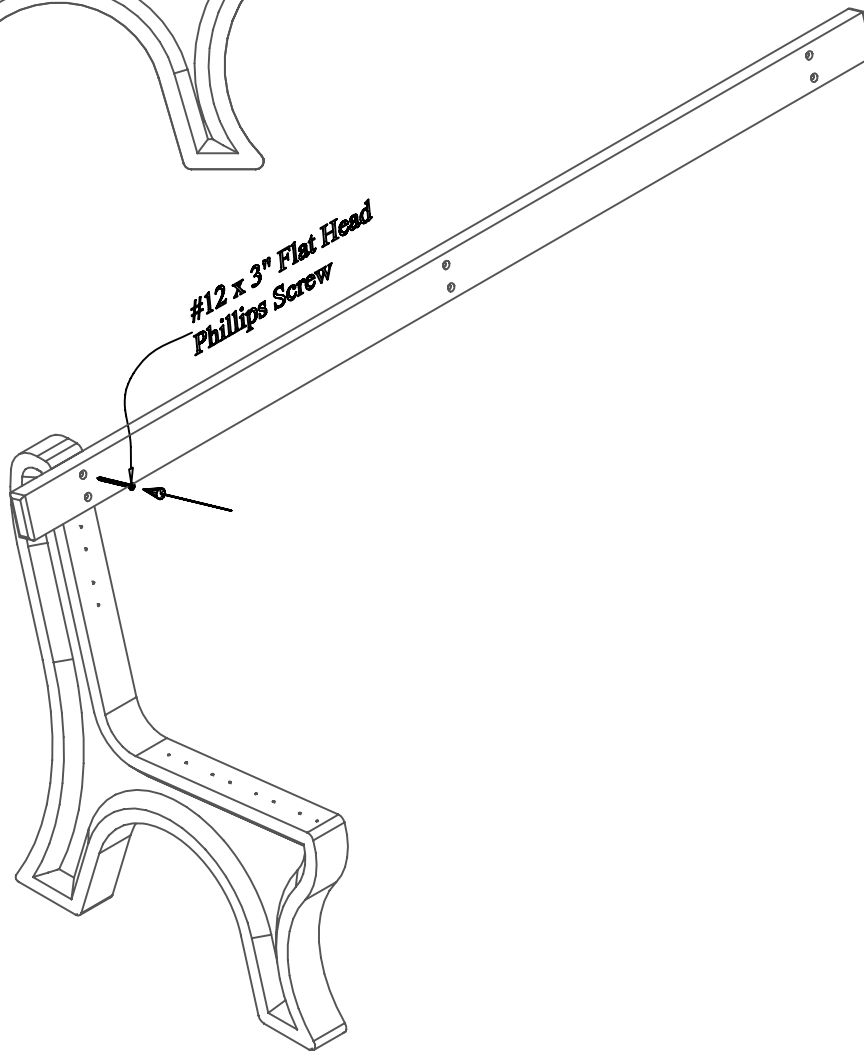

Fig #1:

In order to make the assembly of this Econo-mizer Bench easier while going through the assembly process the board positions are numbered and will be referenced in later steps.



Step #1:

Stand (1) One bench end upright and place (1) One bench board on position 1 being sure to align the pre-drilled holes to the pilot holes in the bench end. After the holes are properly aligned, fasten with (1) One #12 x 3" Flat Head Phillips Screw in the top pre-drilled hole.

Note: Do not tighten screw completely. This will be done in a later step.

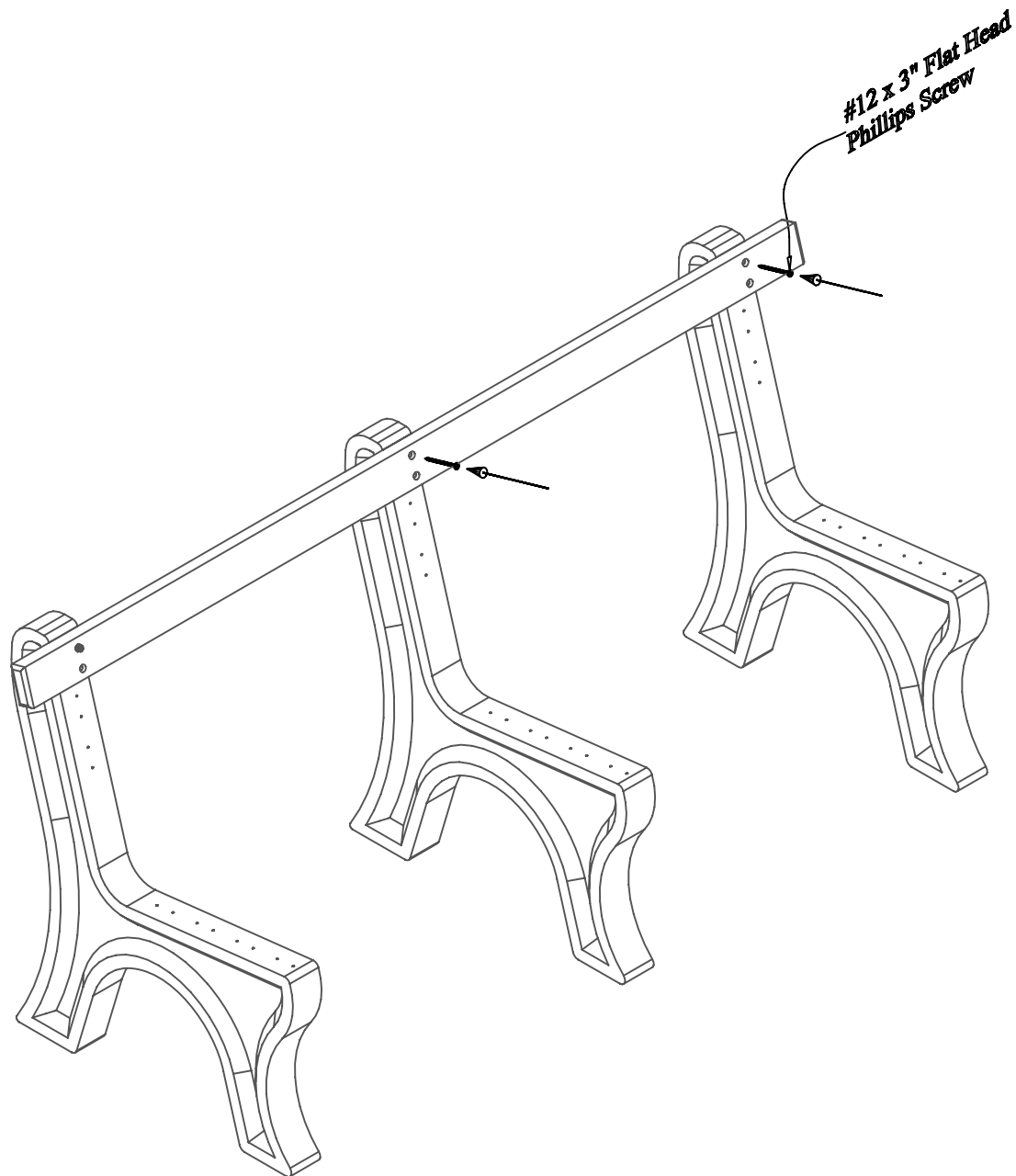

Step #2:

Stand the other (2) Two bench ends upright, one at a time, and place the bench board already attached to the first bench end, on position 1 being sure to align the pre-drilled holes to the pilot holes in the bench end. After the holes are properly aligned, fasten with (1) One #12 x 3" Flat Head Phillips Screw in the top pre-drilled hole.

Note: Do not tighten screws completely. This will be done in a later step.

Step #3:

Align bottom pre-drilled holes to the pilot holes in the bench end. After the holes are properly aligned, fasten with (1) One #12 x 3" Flat Head Phillips Screw per hole.

Note: Be sure to tighten screws completely after this step.

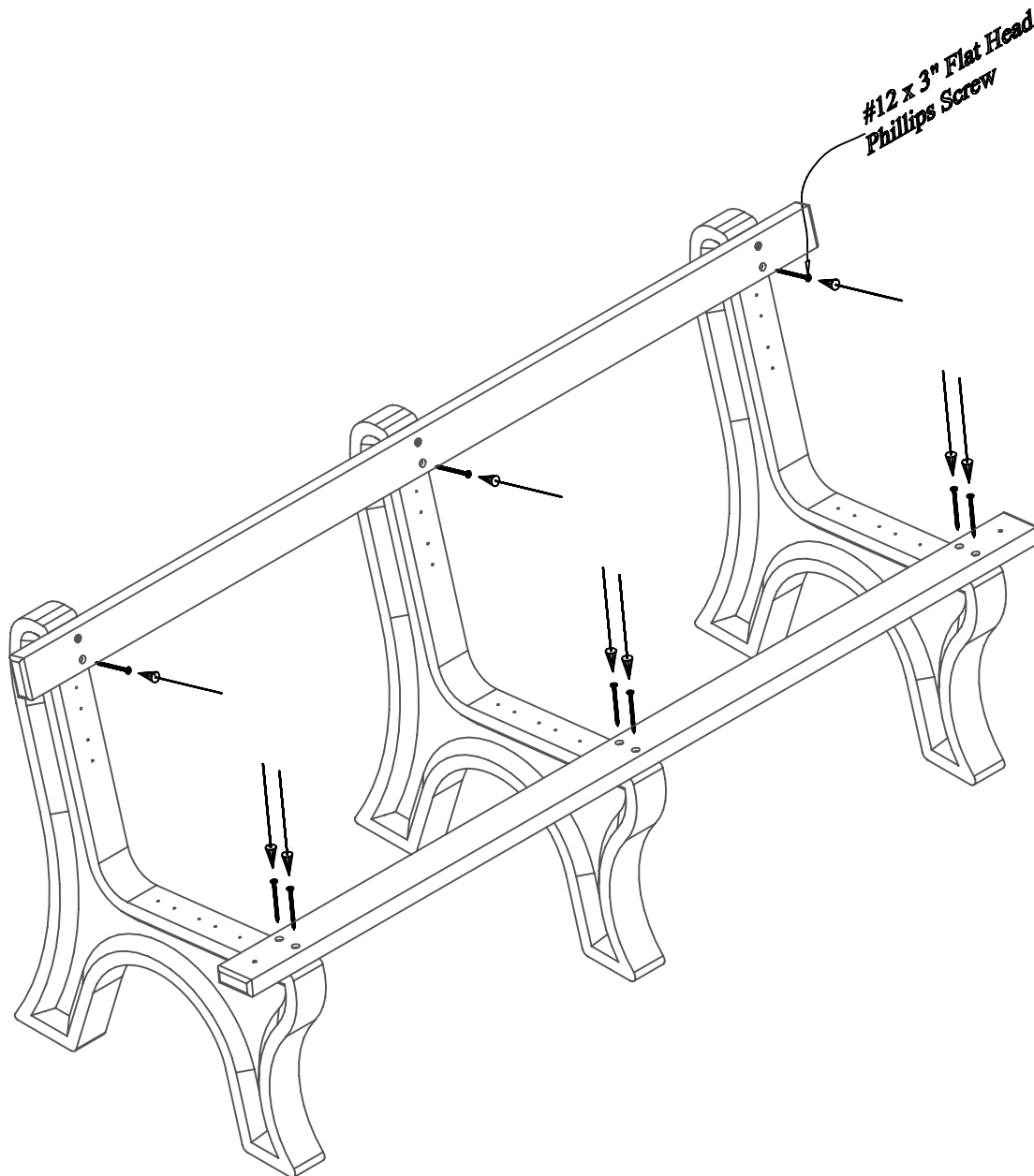

Step #4:

Place a second bench board ow/ arm holes in position 7. Repeat Steps 1 - 3 to attach. Use (1) One #12 x 3" Flat Head Phillips Screw per hole to fasten.

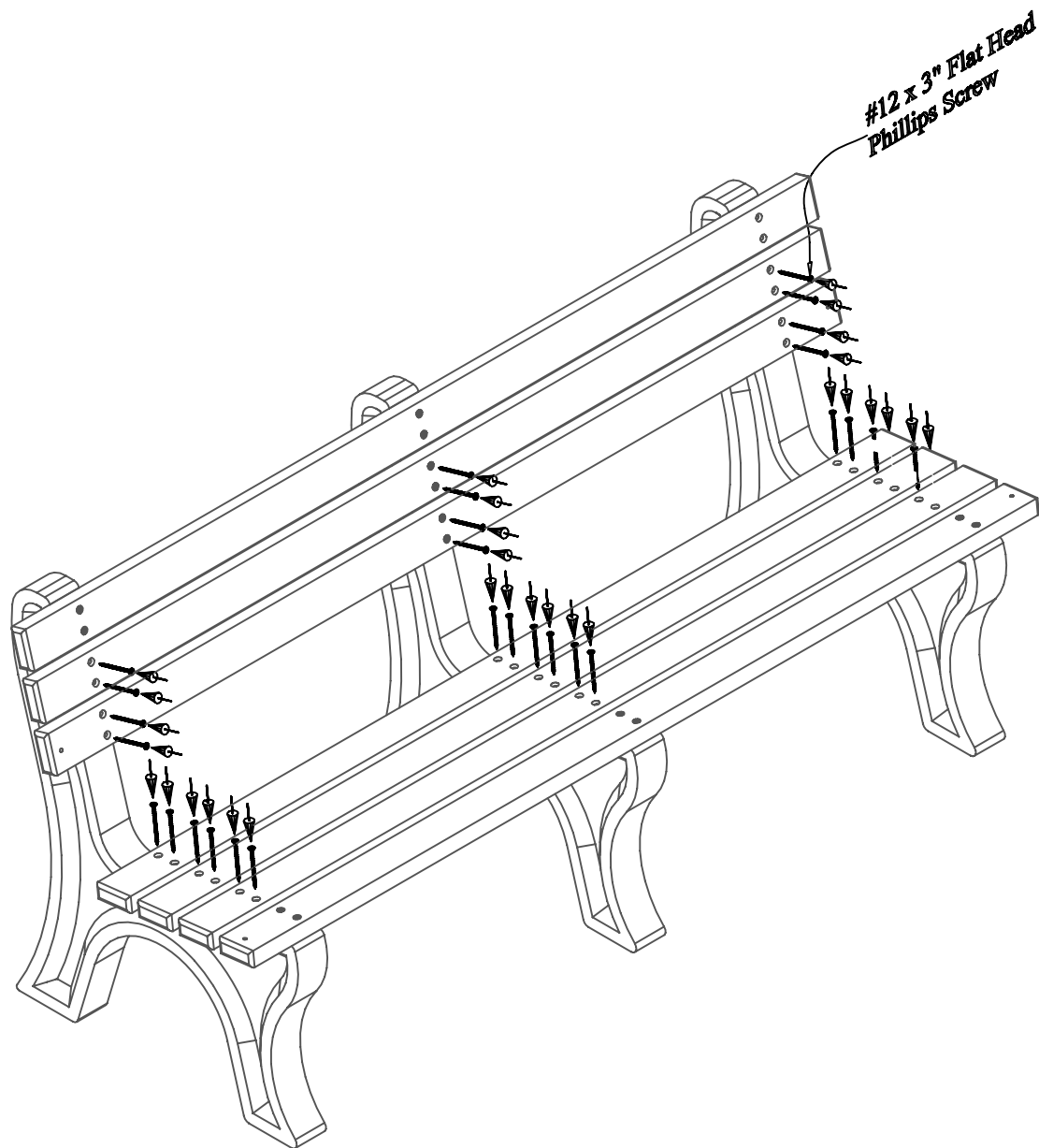

Step #5:

Repeat Steps 1 - 3 to attach bench boards on positions 2, 4, 5 & 6 and a bench board w/arm holes in position 3. Use (1) One #12 x 3" Flat Head Phillips Screw per hole to fasten.

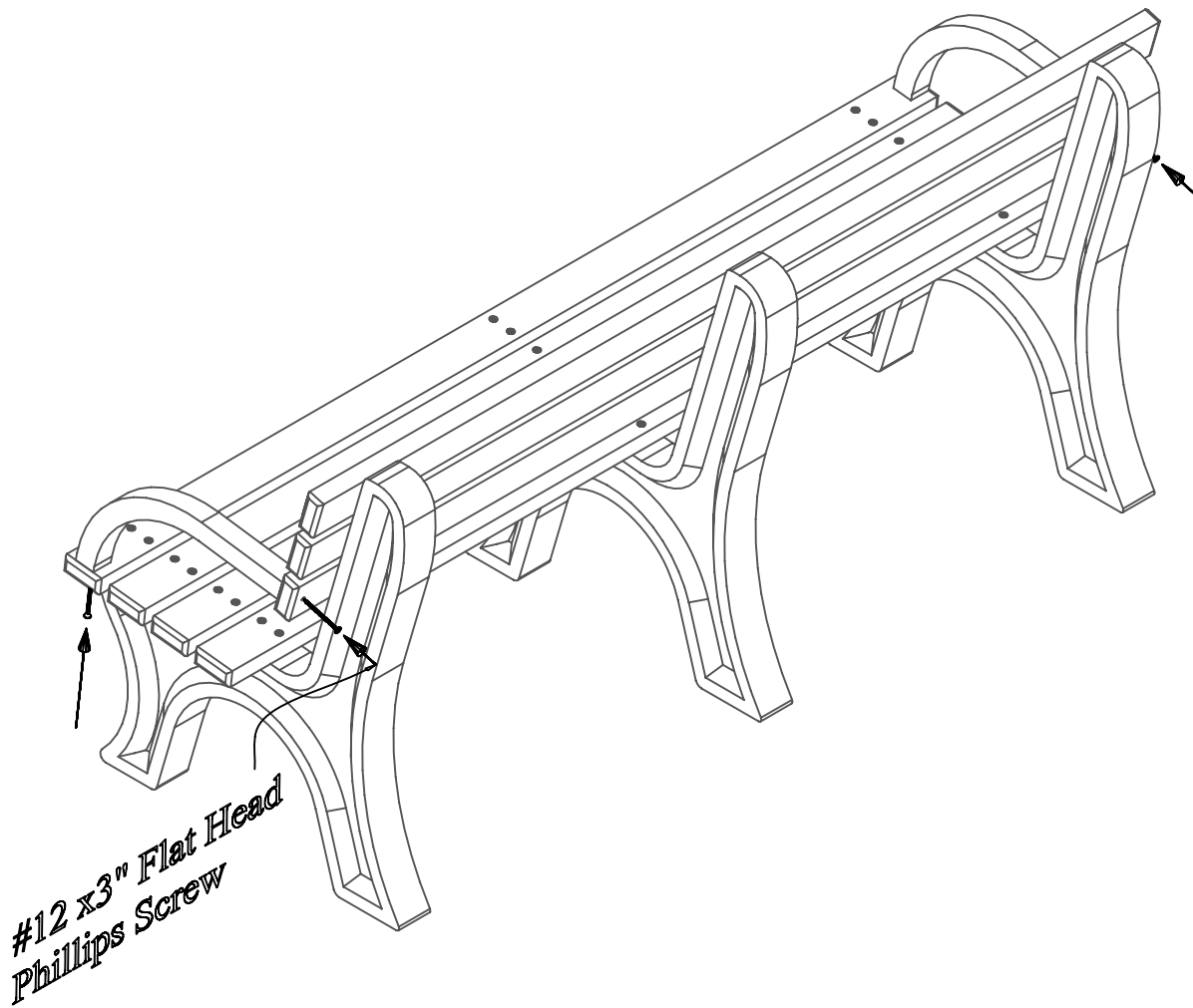

Step #6:

Position the bench arms as shown above. Align the pilot holes to the pre-drilled holes in the bench board w/ armholes. After the holes are properly aligned, fasten with (1) One #12 x 3" Flat Head Phillips Screw per hole.