

Dimensional Information

Model :

KP25SPF - FP

Pedestal Drinking Fountain --
Steel pipe.

Mounting: Surface

NOTE: These rough-in dimensions
may vary 1/2" (13 mm) plus or minus

NOTE: All dimensions subject to
manufacturing variance of plus or
minus 1/4" (6 mm)

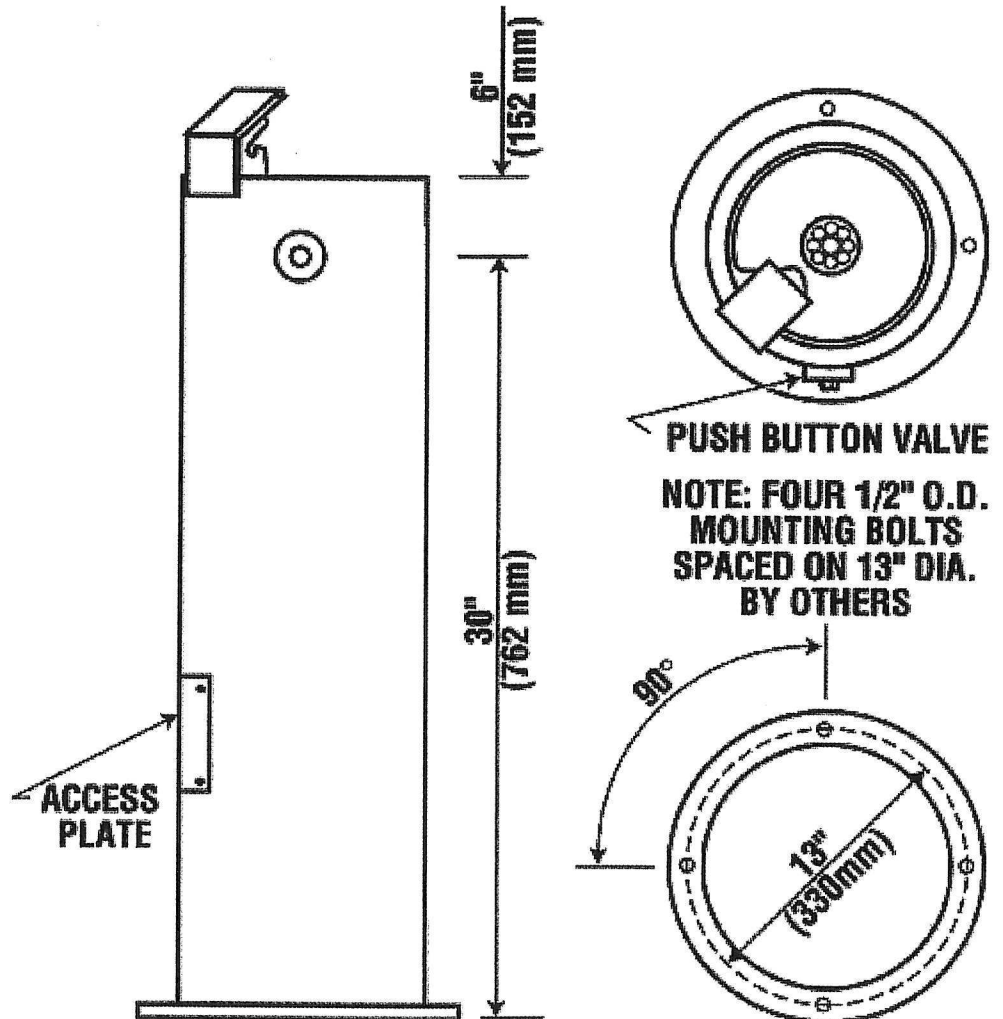

KAY PARK REC. CORP.
 1301 Pine St.
 P.O. Box 477
 Janesville, IA 50647-0477

Dimensional Information

Model

FROST PROOF VALVE SYSTEM FOR MODEL:
 4700, 5325, 5400

NOTE: These rough-in dimensions may vary 1/2" (13 mm) plus or minus

NOTE: All dimensions subject to manufacturing variance of plus or minus 1/4" (6 mm)

