

T46WEBOCTPSM

46" OCTAGONAL WEB STYLE PEDESTAL TABLE SURFACE MOUNT DESIGN

Please take the time to locate and identify each part. Assemble the units on a smooth flat surface. It is also helpful to lay the tops and seats on cardboard or a drop cloth to prevent scratching of the surface during assembly. All parts have been pre-cut and pre-drilled for ease of assembly. All holes are slotted to allow for easy assembly and for final levelling of tops and seats to frames. Fully assemble all parts without totally tightening nuts and bolts. After all assembled go back and retighten nuts to bolts. DO NOT OVER TIGHTEN NUTS TO BOLTS. Over tightened nuts can crack the plastisol coating. All the necessary quantities of parts required are listed in this assembly instructions.

DO NOT BEGIN ASSEMBLY UNTIL YOU HAVE READ THESE INSTRUCTIONS AND ARE FAMILIAR WITH THE PARTS.



PARTS IDENTIFICATION

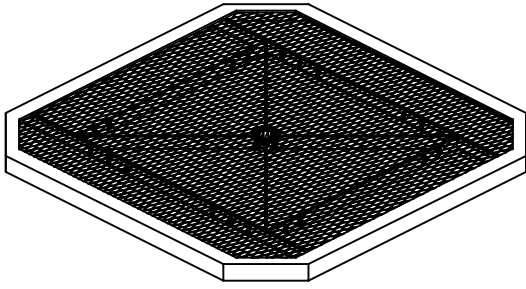

(A) 46" OCT TOP

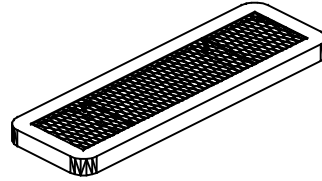

(B) 38" RC SEAT

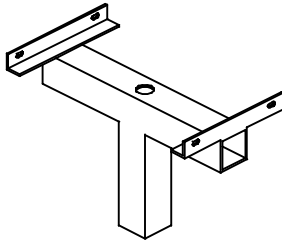

(C) CENTER POST

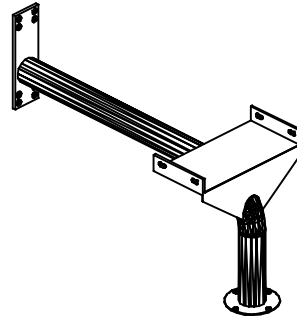

(D) PEDESTAL ARMS

PARTS LIST

ITEM	PART#	DESCRIPTION	QTY.
A	TT46OCT	46" OCT TOP	1
B	S38RC	38" RC SEAT	4
C	F46PEDCP	CENTER POST	1
D	F46WEBARMSM	PEDESTAL ARM WEB	4

ITEM	HARDWARE DESCRIPTION	QTY.
HW1	5/16" X 18 NYL LOCKNUTS	20
HW2	5/16" X 18GA CAP BOLTS	20
HW3	5/16" FLAT WASHERS	40
HW4	BOLT GUARDS	20
HW5	5/8" BOLTS	8
HW6	5/8" NUTS	8

ASSEMBLY TOOLS REQUIRED
2- 1/2" WRENCHES

HARDWARE IDENTIFICATION



(HW1) 5/16" X 18
NYL LOCKNUTS

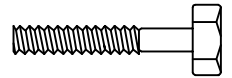

(HW2) 5/16" X 18
GAUGE CAP BOLTS



(HW5) 5/8" NUTS



(HW3) 5/16"
FLAT WASHERS



(HW4) BOLT
GUARDS



(HW6) 5/8" BOLTS

ASSEMBLY PROCEDURES

STEP 1

BOLT THE FOUR ARMS TO THE CENTER POST USING EIGHT 5/8" BOLTS AND EIGHT 5/8" NUTS,
Hand tighten at this time.

STEP 2

SET THE TOP ON THE CENTER POST ALIGNING HOLES IN TOP BRACES WITH HOLES IN THE ANGLE
IRON ON CENTER POST. FASTEN WITH FOUR 5/16" BOLTS, EIGHT WASHERS AND FOUR 5/16" NUTS.
Hand tighten at this time.

STEP 3

SET SEATS ON THE SEAT BRACKETS OF THE ARMS. BRACES ON SEAT SHOULD
SET TO THE OUTSIDE OF THE SEAT BRACKET ON THE ARM.
FASTEN WITH FOUR 5/16" BOLTS, EIGHT WASHERS AND FOUR 5/16" NUTS PER SEAT.

STEP 4

TIGHTEN ALL BOLTS LEVELING AND SLIGNING PARTS AS YOU GO.
DO NOT OVER TIGHTEN AS THIS WILL CAUSE THE PLASTISOL COATING TO CRACK.

STEP 5

ATTACH TO A SMOOTH LEVEL SURFACE.
SURFACE MOUNTING HARDWARE NOT INCLUDED.

1	CAP BOLT & WASHER
2	WASHER & LOCK NUT

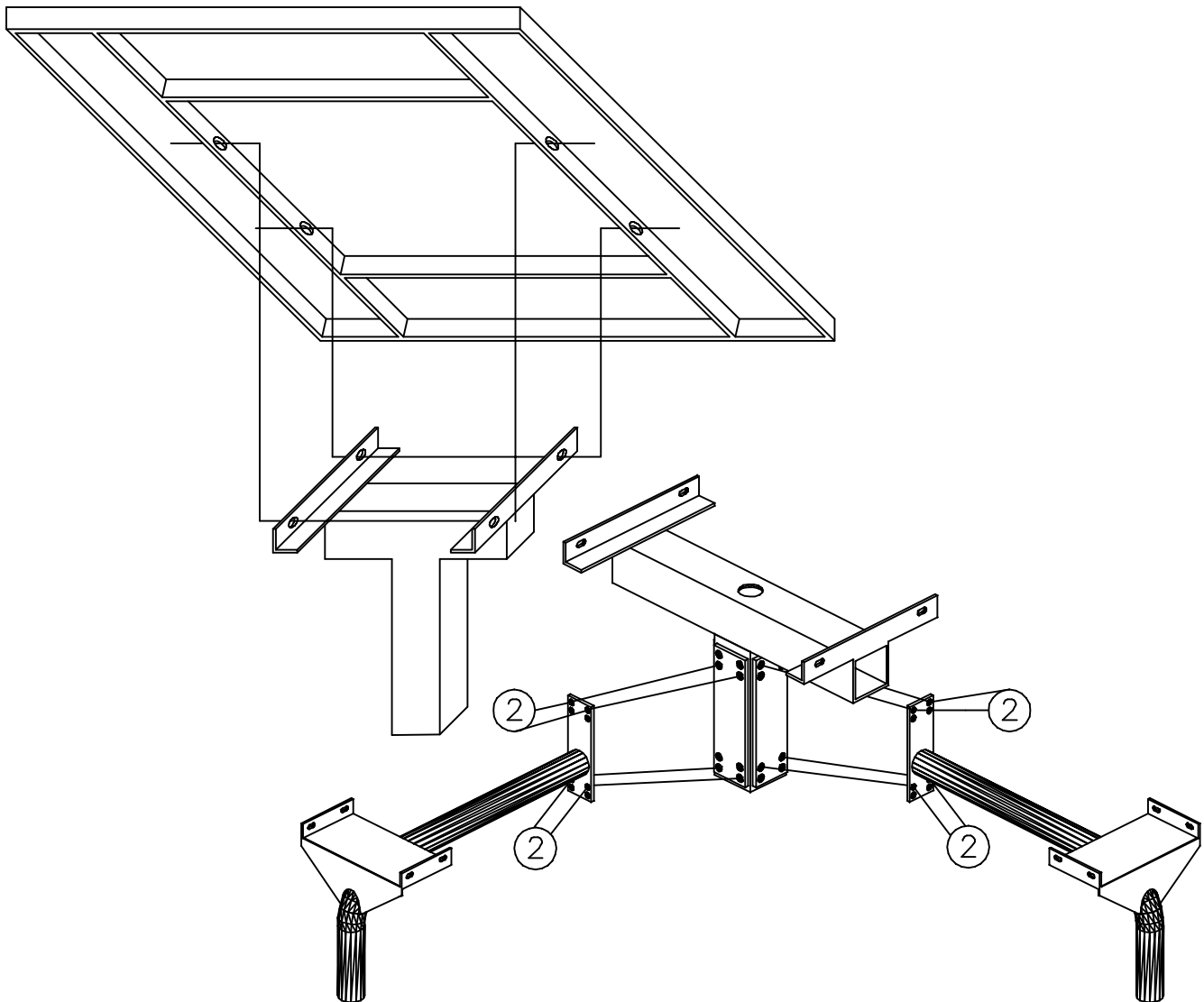

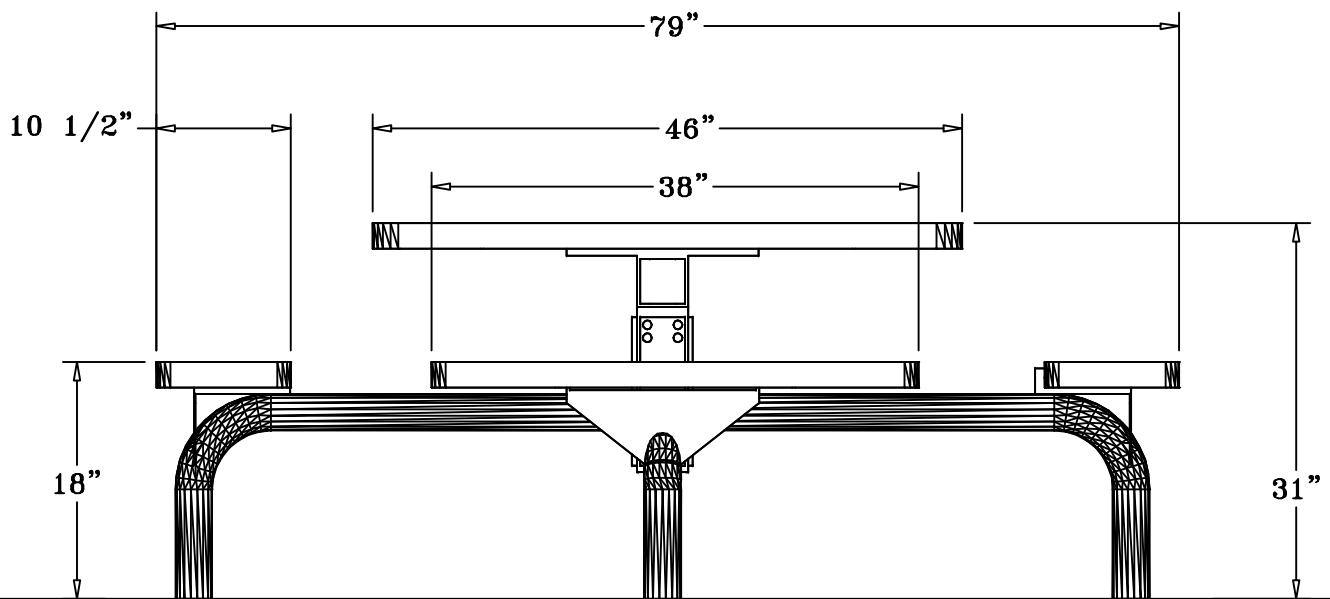

SPECIFICATIONS

46" OCTAGONAL TABLE WITH FOUR ATTACHED 38" X 10 1/2" SEATS.
 FRAME IS SURFACE MOUNT DESIGN.

COATED WITH A 1/8" TO 1/4" THICK PLASTISOL ULTRAVIOLET STABILIZED VINYL COATING FUSED
 AND BAKED TO A 90% GLOSS.

TABLE HEIGHT IS 31" APPROXIMATELY. SEAT HEIGHT IS 18" APPROXIMATELY.
 TOTAL OVERALL SQUARED DIMENSION IS 79" APPROXIMATELY.

TOP AND SEATS ARE MADE WITH HEAVY DUTY 3/4" #9 EXPANDED METAL INSIDE OF A 2" X 2"
 X 1/8" ANGLE IRON FRAME.

FRAME IS A SINGLE 4" X 4" PEDESTAL MOUNTED TO THE CENTER OF THE TABLE TOP. EXTENDING
 OUT FROM THE 4" SQUARE TUBING ARE FOUR 2 7/8" ROUND TUBING ARMS THAT THE SEATS ARE
 MOUNTED TO. COATED WITH A BAKED ON POLYESTER POWDER COAT FINISH.

ALL HARDWARE IS NON-CORROSIVE.

WEIGHT FOR THE T46WEBOCTPSM IS 284 LBS.

MAINTENANCE

To maintain luster it is recommended to wash, rinse, and dry the units after prolonged use.
 Check for loose bolts and nuts and tighten as needed. Contact the factory for genuine
 Webcoat part replacements if needed.