

801-212M-H See Saw 2 Seat

IMPORTANT

PLEASE READ THESE INSTRUCTIONS BEFORE COMMENCING ASSEMBLY. Please retain this instruction sheet in your files. It contains important replacement parts information. All equipment must be installed in accordance with these instructions. It is important to use and maintain all public playground equipment properly. Playground equipment, which is improperly maintained, can cause serious injury. Periodical inspections, maintenance, repair and/or replacement of damaged parts is necessary for safe operation of equipment. Appropriate publications, available at no charge, from the consumer product safety commission, include "A Handbook for Public Playground safety". You can receive your free copy by calling 1-301-504-7908.

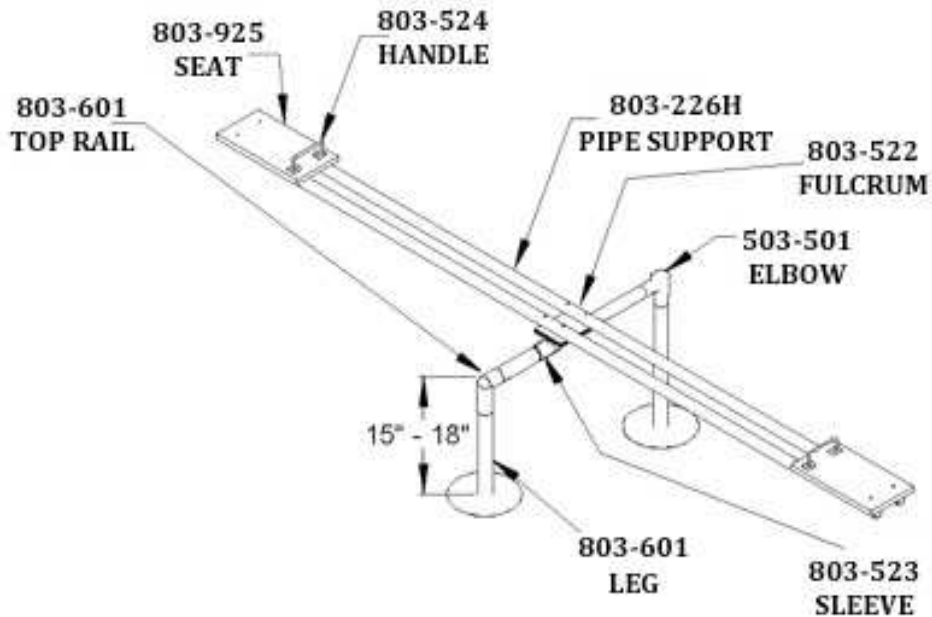

<u>PACKING LIST</u>			<u>HARDWARE BAG</u>			
1	CTN	1	Hardware Bag	4	105-017	2 3/8" Pipe Plug
		2	503-501 Elbow	6	196-802	1/2" x 1/2" Socket Set Screw
		1	803-522 Fulcrum	8	116-550	5/16" x 3" B.H. Bolt
		2	803-523 Sleeve	4	116-543	5/16" x 2 1/4" B.H. Bolt
		2	803-524 Handle	12	326-501	5/16" Lock Washer
		2	803-925 Seat Boards	12	216-512	5/16" x 1" B.H. Nut
1	BDL	3	803-601 Pipe 2 3/8" OD x 3' 6" Long	1	416-400	1/4" Socket Key
2	PIPE	1	803-226H Support	2	416-350	3/16" Socket Key
				1	516-350	Permabond Threadlocker Tube
				1	805-532	Warning Label
				1	805-534	SportsPlay Label
				1		Maintenance Checklist

1 CTN	1 BDL	2 PIPE	4 TOTAL PCS	145# Weight	Class 70
-------	-------	--------	-------------	-------------	----------

GENERAL USE/FALL ZONE & FOOTING RECOMMENDATIONS:

Stationary & portable equipment - use/fall zones should extend a minimum of 6 feet in all directions from the perimeter of the equipment ground space. This area should be covered with the required amount of resilient safety surfacing material. For some equipment - use/fall zones can overlap. See Consumer Product Safety Commission guidelines. Diameter & depth of footings illustrated are satisfactory in most applications for pipe sizes up to 2 3/8" diameter. Varying soil & climactic conditions may require deeper & heavier footings in some areas. Check local building codes.

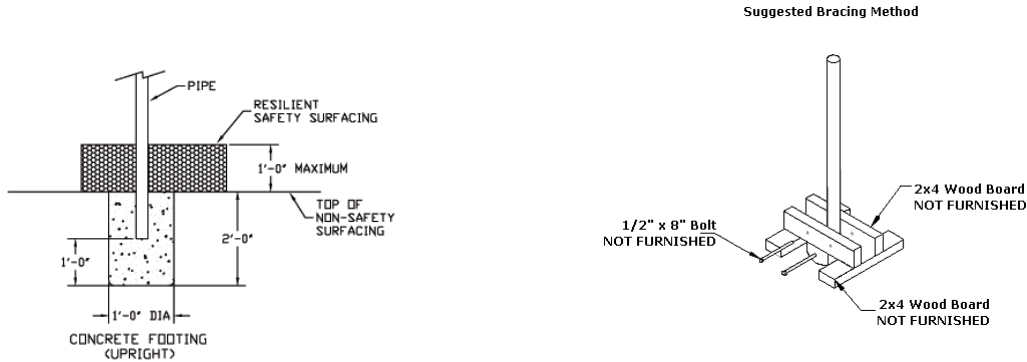

- If resilient surfacing is to be less than 12", then additional pipe should be put in concrete to maintain proper finish grade for equipment.

USE AREA & FOOTING:

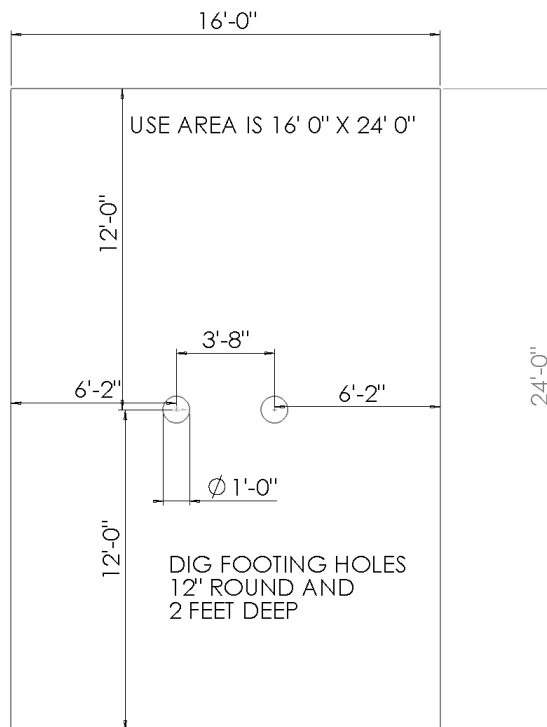

SPECIFIC INSTRUCTIONS:

Car tires (not furnished) or some other shock-absorbing material should be embedded in the ground beneath the seats to minimize the risk of injury due to abrupt contact with the ground. Also, lengths of standard 2 x 4's can be easily positioned between the pipe rails to prevent children from putting their feet between the rails.

GENERAL MAINTENANCE INSTRUCTIONS:

Check MONTHLY for loose bolts, damaged or broken parts. Tighten and/or replace immediately.

SPECIFIC ASSEMBLY AND INSTALLATION:

NOTE: All button head nuts are placed on the pipe side of the spots where attached and the lock washers are placed on the Bolts. DO NOT tighten nuts more than hand-tight until entire assembly is completed.

- STEP #1: Mark and dig holes according to Foot/Use Diagram.
- STEP #2: Assemble frame by first attaching one leg to top rail using elbow. Tighten set screws on elbow. Slide sleeve on top rail then slide fulcrum and other sleeve. Tighten sleeve set screws to hold fulcrum in place in the center of the top rail. Attach remaining elbow and leg. DO NOT attach see saws at this time.
- STEP #3: Prop in holes, leaving 15-18" distance from surface to top of frame, plumb, level and pour concrete. Allow at least 48 hours for concrete to harden.
- STEP #4: After concrete has hardened, attach the rest of the equipment. Use the 5/16" x 2 1/4" button head bolts, lock washers and button head nuts to attach the long pipe supports to the fulcrums. Use the 5/16" x 3" button head bolts, lock washers and button head nuts to attach the seat and handle to the pipe supports. Use Threadlocker on all button head fasteners. Drive pipe plugs into the open ends of the pipe supports.
- STEP #5: Attach Warning Label and Manufacturer's Identification Label to a clean surface. The labels should be attached in a location where they are clearly visible and legible and away from normal hand and foot placement areas. The labels must be replaced if they become illegible, destroyed or are missing. Contact your SportsPlay distributor for replacement labels.