

TIRE CHALLENGE

902-874

ITEM NO.	PART NUMBER	DESCRIPTION	QTY.
1	913-367	Tire Challenge	1
2	913-368	Tire Challenge Leg	11
3	126-701BPS	3/8" x 1-1/4" Button Pin SS	11
4	316-601	3/8" Flat Washer	11
5	416-505BPK	7/32" Long Arm Button Pin Key	1
6	516-400	LockTite	1

INSTRUCTIONS:

1. Attach 11 legs to Tire Challenge as shown in Detail A. Tighten hardware, lock tite may be used also.
2. Stand Tire Challenge in desired location and mark all hole locations.
3. Dig holes per footing diagram.
4. Place assembly in holes so that the top of plastic is no more than 8" above protective surfacing. Brace and concrete in ground.
5. Install safety surfacing.

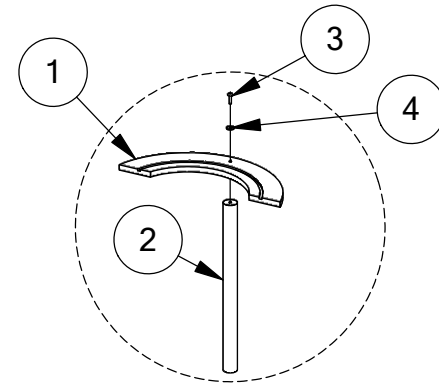

DETAIL A

FOOTING DIAGRAM

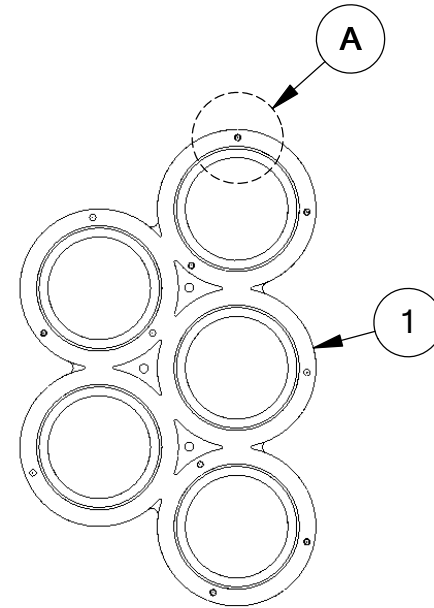
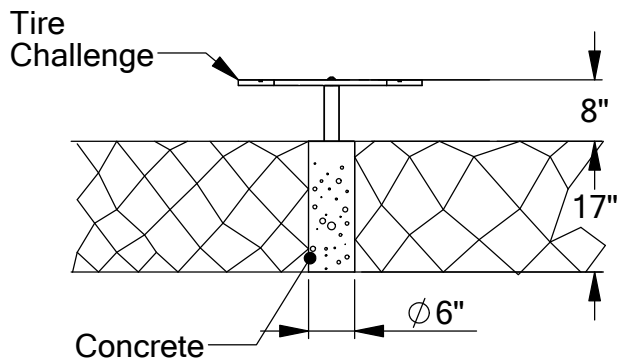

5

↑

4

3

2

1