

Model Numbers:
 TRD46-B-04-000 - Advantage Coating
 TRD46-D-04-000 - Industry Standard Coating

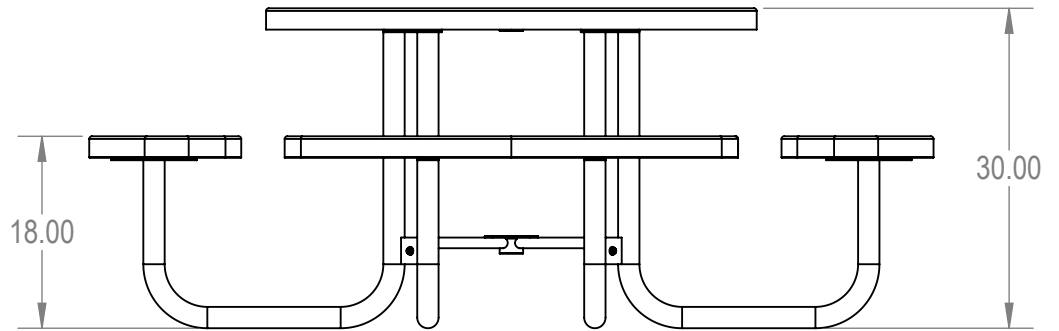
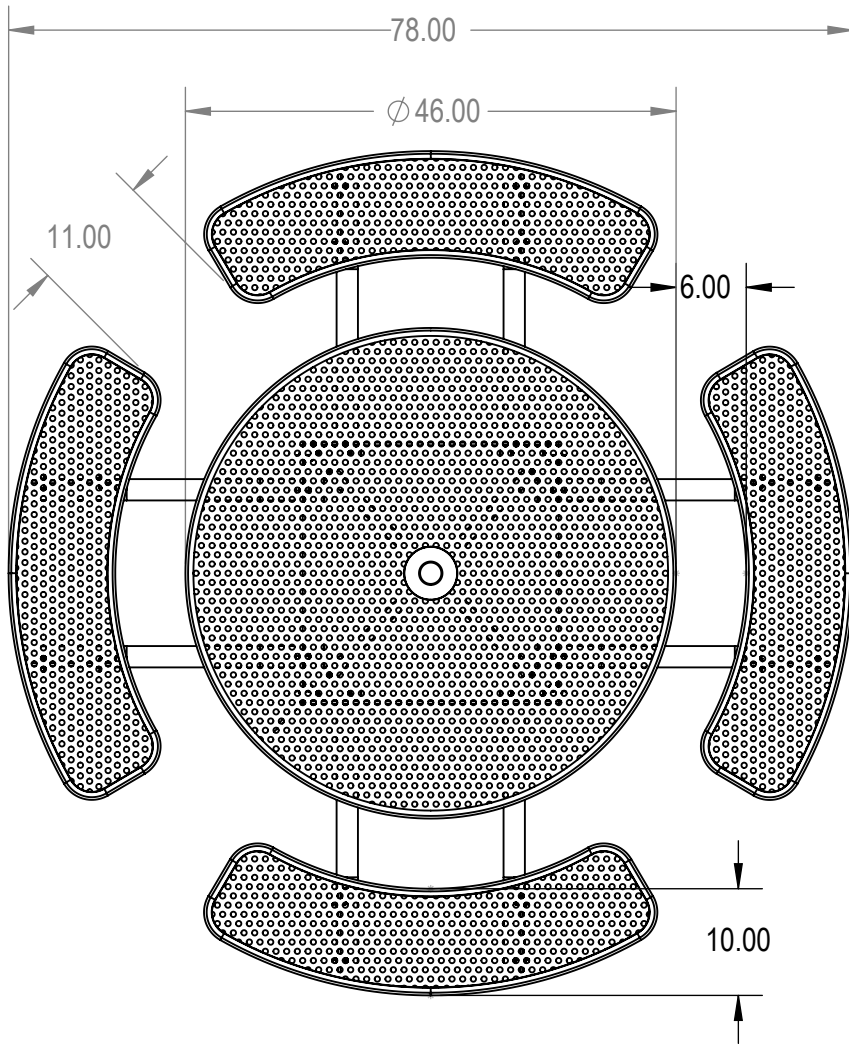

TERRA BOUND
 SOLUTIONS™

PROPRIETARY AND CONFIDENTIAL

THE INFORMATION CONTAINED IN THIS DRAWING IS THE SOLE PROPERTY OF Advantage Panels & Fence, Inc. PO Box 1790 Whitney, TX. ANY REPRODUCTION IN PART OR AS A WHOLE WITHOUT THE WRITTEN PERMISSION OF Advantage Panels & Fence, Inc. PO Box 1790 Whitney, TX. IS PROHIBITED.

	NAME	DATE
DRAWN	GM	1/3/2016
SALES APPR.		
CLIENT APPR.		
MFG APPR.		
Q.A.		

Design By -

A Advantage Panels & Fence, Inc.

TITLE:
46in Round Table - Portable
Perforated Metal Version

SIZE	DWG. NO.	REV
A		

WEIGHT: SHEET 3 OF 3