

Model Numbers:

TOT46-A-04-000 - Advantage Coating

TOT46-C-04-000 - Industry Standard Coating

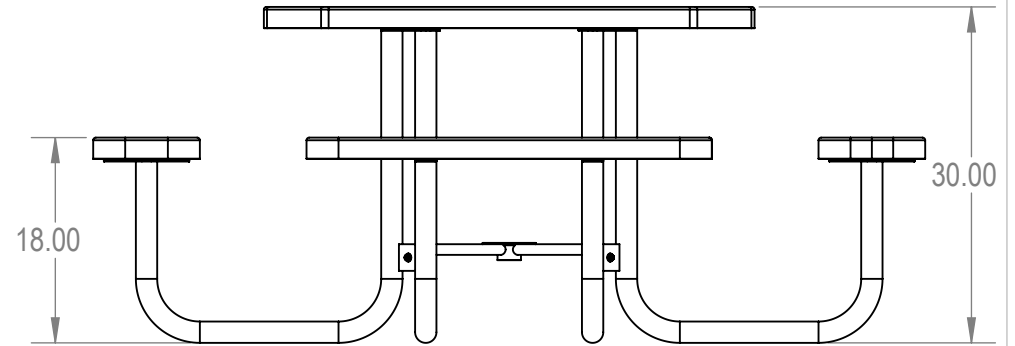
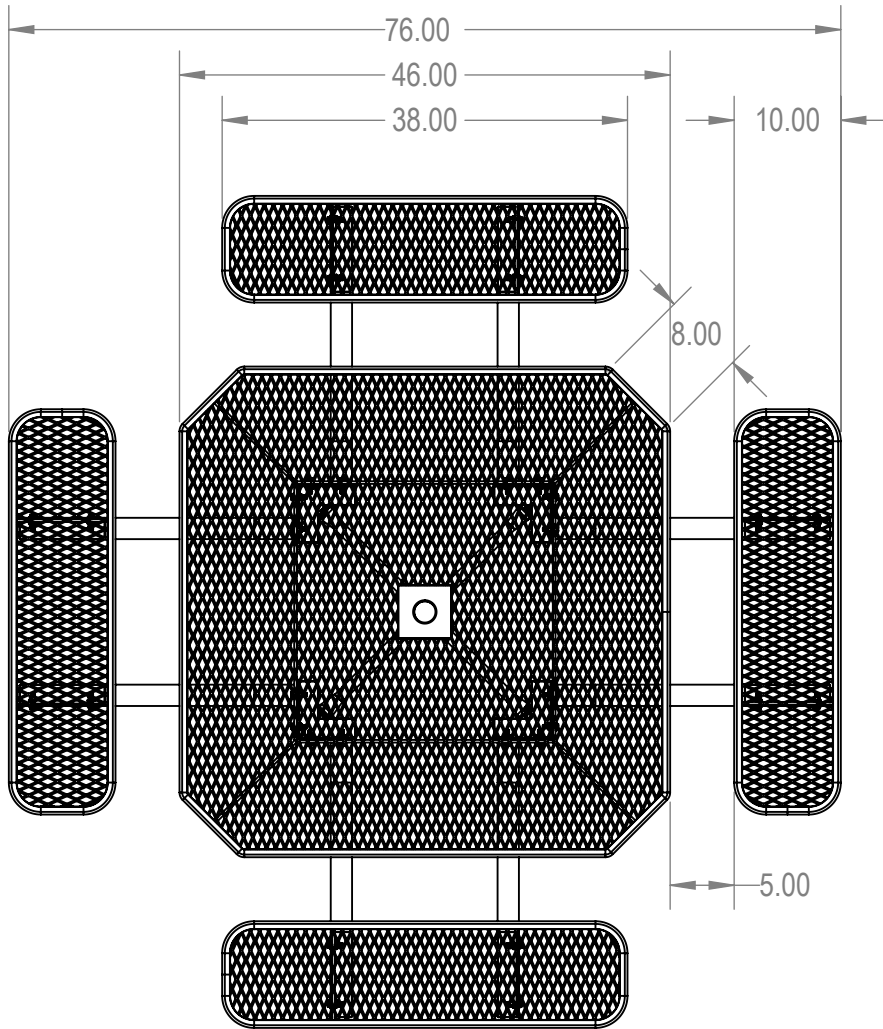

TERRA BOUND
SOLUTIONS™

PROPRIETARY AND CONFIDENTIAL

THE INFORMATION CONTAINED IN THIS DRAWING IS THE SOLE PROPERTY OF Advantage Panels & Fence, Inc. PO Box 1790 Whitney, TX. ANY REPRODUCTION IN PART OR AS A WHOLE WITHOUT THE WRITTEN PERMISSION OF Advantage Panels & Fence, Inc. PO Box 1790 Whitney, TX. IS PROHIBITED.

	NAME	DATE
DRAWN	GM	1/8/2016
SALES APPR.		
CLIENT APPR.		
MFG APPR.		
Q.A.		

Design By -

A Advantage Panels & Fence, Inc.

TITLE:

Octagon Table
Expanded Metal Version

SIZE
A

DWG. NO.

REV

WEIGHT:

SHEET 2 OF 3