

TURTLE CLIMBER

301-144

ITEM NO.	PART NUMBER	DESCRIPTION	QTY.
1	113-044	Shell	1
2	000-000	Turtle Feet Panel	2
3	113-601	Post	4
4	000-000	Head (Left & Right)	2
5	126-706	3/8" x 2" Buttonhead Bolt	4
6	905-803	Corner Bracket	12
7	116-529	5/16" x 3/4" Buttonhead Bolt	20
8	216-512	5/16" x 1" Buttonhead Nut	23
9	316-501	5/16" Flat Washer	23
10	316-601	3/8" Flat Washer	27
11	116-530	5/16" x 1" Buttonhead Bolt	1
12	116-535	5/16" x 1-1/2" Buttonhead Bolt	2
13	416-350	3/16" Socket Key	2
14	416-505	7/32" Long Arm Key	1
15	000-000	Lock Tite	1

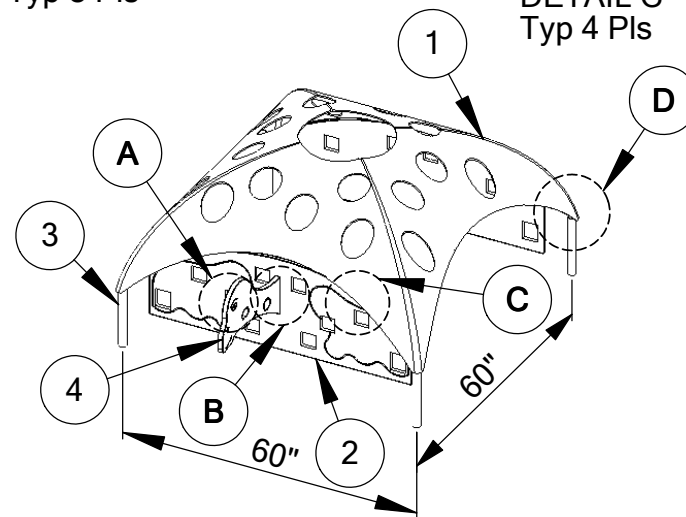
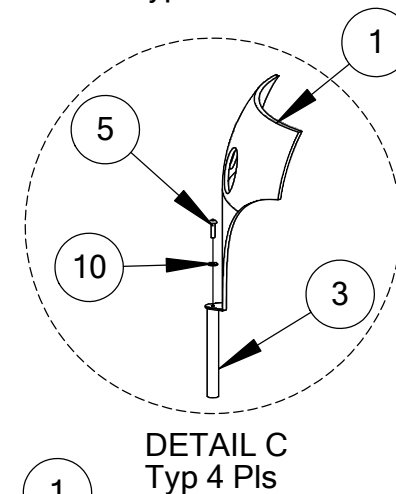
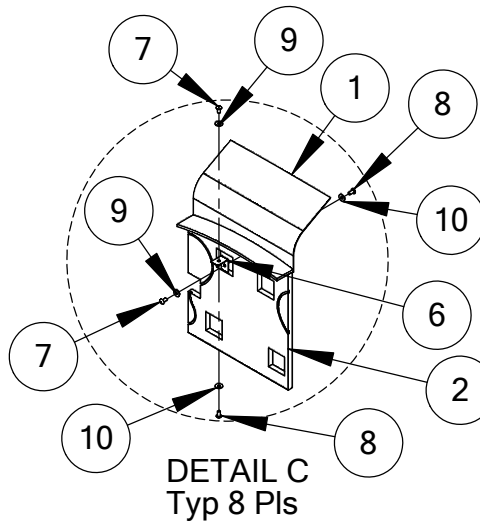
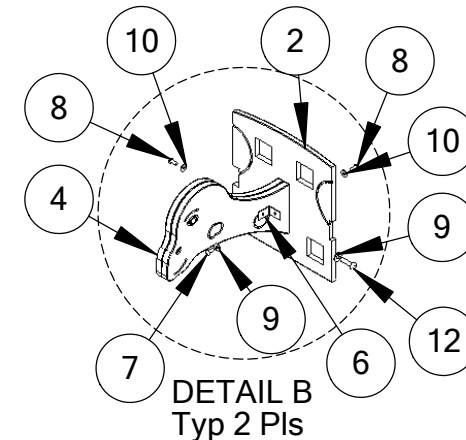
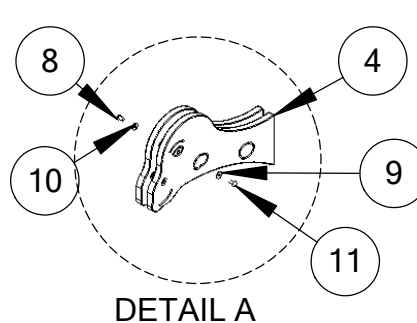

IMPORTANT

PLEASE RETAIN THIS INSTRUCTION SHEET IN YOUR FILES. IT CONTAINS IMPORTANT REPLACEMENT PARTS INFORMATION. ALL EQUIPMENT SHOULD BE INSTALLED IN ACCORDANCE WITH THESE INSTRUCTIONS.

IT IS IMPORTANT TO USE AND MAINTAIN ALL PUBLIC PLAYGROUND EQUIPMENT PROPERLY. PLAYGROUND EQUIPMENT, WHICH IS IMPROPERLY MAINTAINED, CAN CAUSE SERIOUS INJURY. PERIODICAL INSPECTIONS, MAINTENANCE, REPAIR AND/OR REPLACEMENT OF DAMAGED PART IS NECESSARY FOR SAFE OPERATION OF EQUIPMENT AND SAFETY OF USERS. RESILIENT SURFACING SHOULD BE USED UNDER ALL PLAYGROUND EQUIPMENT. APPROPRIATE PUBLICATIONS, AVAILABLE AT NO CHARGE, FOR THE CONSUMER PRODUCT SAFETY COMMISSION, INCLUDE "A HANDBOOK FOR PUBLIC PLAYGROUND SAFETY." YOU CAN RECEIVE YOUR FREE COPY BY CALLING 1-301-504-7908.

GENERAL ASSEMBLY INSTRUCTIONS:

Check all the parts and hardware with the packing list to be sure you have received everything needed to assemble this product.

CONTACT YOUR LOCAL DISTRIBUTOR WITH NOTIFICATION OF ANY MISSING OR DAMAGED PARTS.

Contact must be made within 10 days of receipt of your order. Only hand-tighten nuts and bolts on initial assembly. Final tightening should be done EVENLY after final assembly when unit has been plumbed and leveled.

GENERAL MAINTAINANCE INSTRUCTIONS

Check MONTHLY for loose bolts, damaged, or broken parts. Tighten and/or replace immediately.

SPECIFIC ASSEMBLY INSTRUCTIONS

STEP 1: Turn shell upside down and attach the (4) 113-601 legs to the four corners of the shell with 3/8" x 2" Hex Nuts and 3/8" lock washers.

STEP 2: Turn shell on the legs, place in the desired location, and mark the hole locations for all 4 legs. Dig the 4 holes per the footing layout.

STEP 3: Install the plastic panels as shown in the detail drawings. Tighten all plastic panel hardware.

STEP 4: With the help of another person, lower the shell into the 4 holes. Make sure the shell is level all directions and concrete. Allow 48 hours for concrete to cure.

Step 5: Make sure all the hardware is tight.

STEP 6: Install safety surfacing.