

8 Foot Traditional Park Bench w/ Arms

For Fastener Pack
(FP-TB8BA-CU-02)

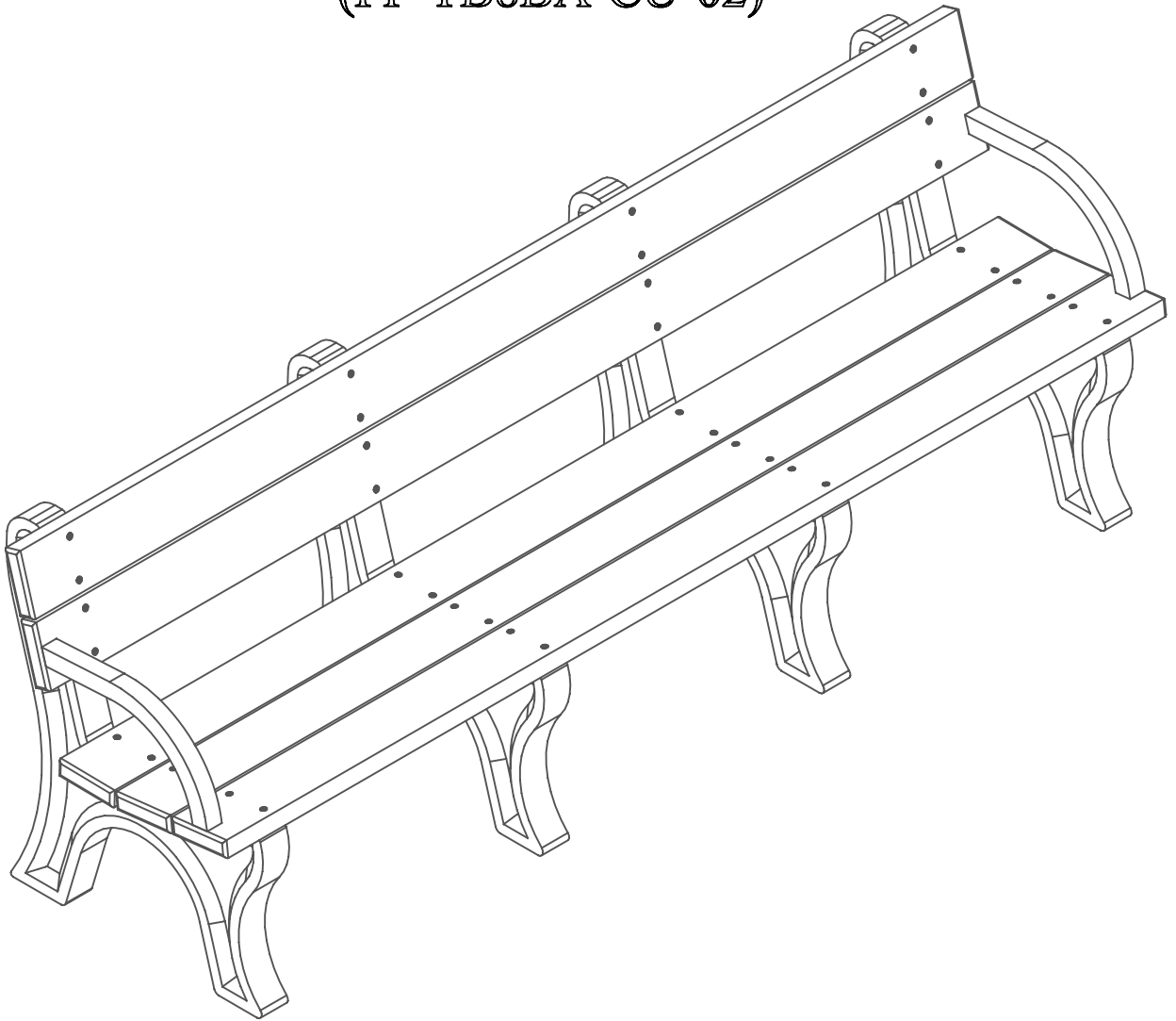

Congratulations !!

You have just purchased the finest recycled plastic
park bench available. Enjoy !!!

Before assembly, please make sure all components are included.

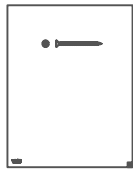

(1) - One Fastener Pack
FP-TB8BA-CU-02

FP - Fastener Pack

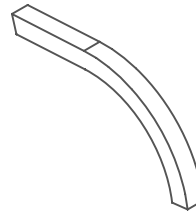

D - Bench Arm

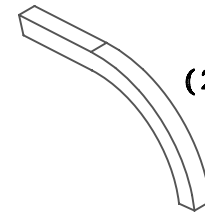

D - Bench Arm

(2) - Two Bench arms
BP-BA-A-01

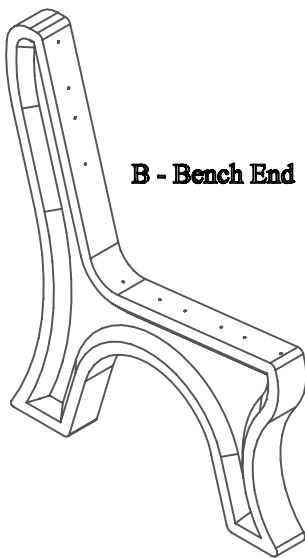

B - Bench End

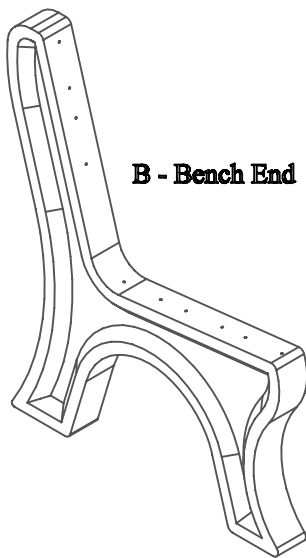

B - Bench End

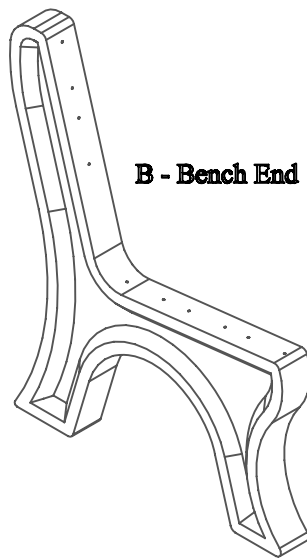

B - Bench End

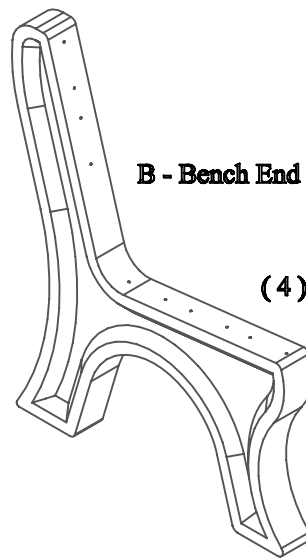

B - Bench End

(4) - Four Bench Ends
PS-SBBE-T-02

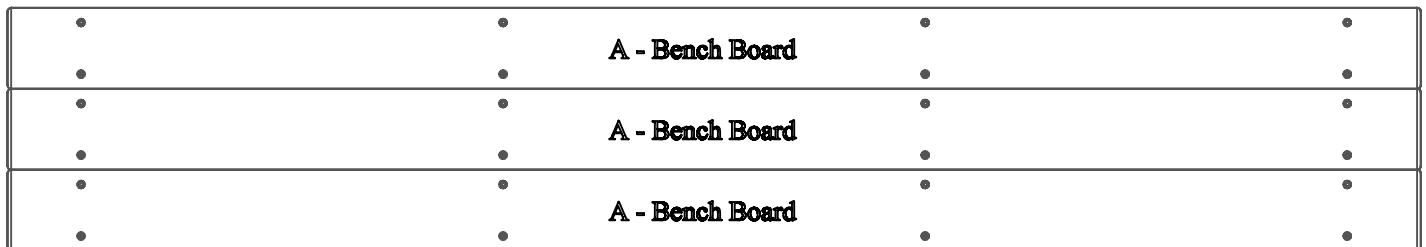

(3) - Three Bench Boards
BP-TB8B-A-02

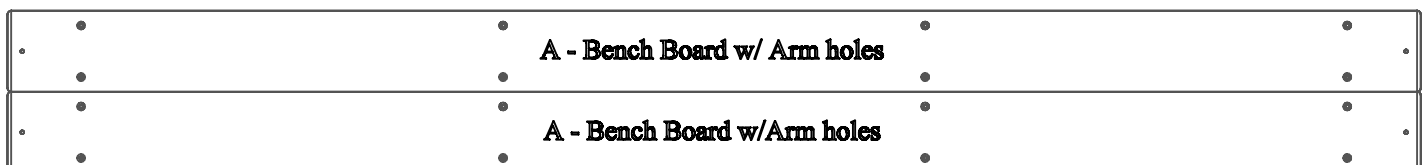

(2) - Two Bench Boards w/ Arm holes
BP-TB8BA-A-02

Before assembly, please make sure all fasteners are included.

44 - #12 x 3" Flat Head Phillips Screw



Also needed for this assembly will be the following materials:

1 - #3 Phillips Drive Bit

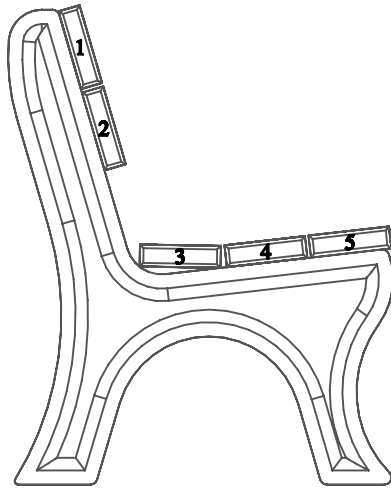
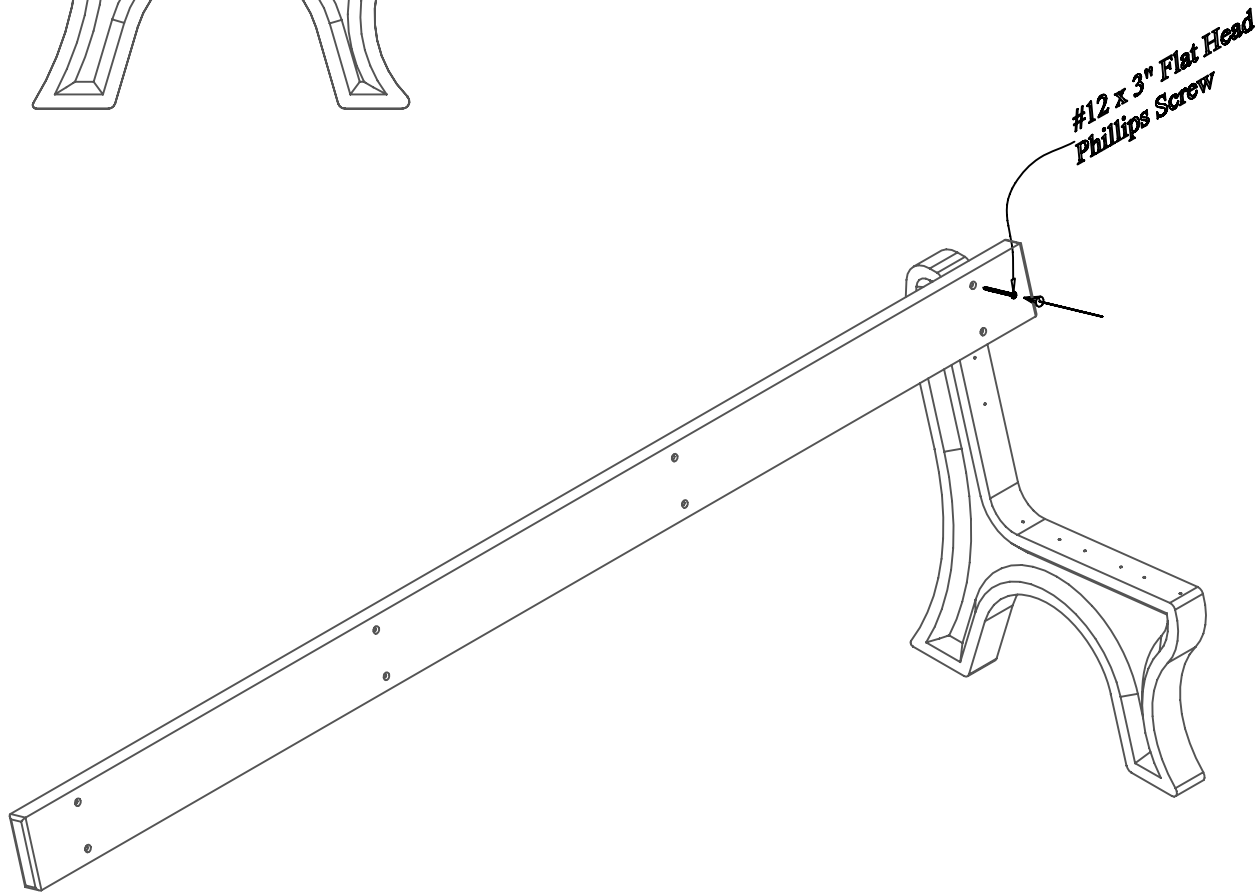

Fig #1:

In order to make the assembly of this Traditional Bench easier while going through the assembly process the board positions are numbered and will be referenced in later steps.



Step #1:

Stand (1) One bench end upright and place (1) One bench board on position 1 being sure to align the pre-drilled holes to the pilot holes in the bench end. After the holes are properly aligned, fasten with (1) One #12 x 3" Flat Head Phillips Screw in the top pre-drilled hole.

Note: Do not tighten screw completely. This will be done in a later step.

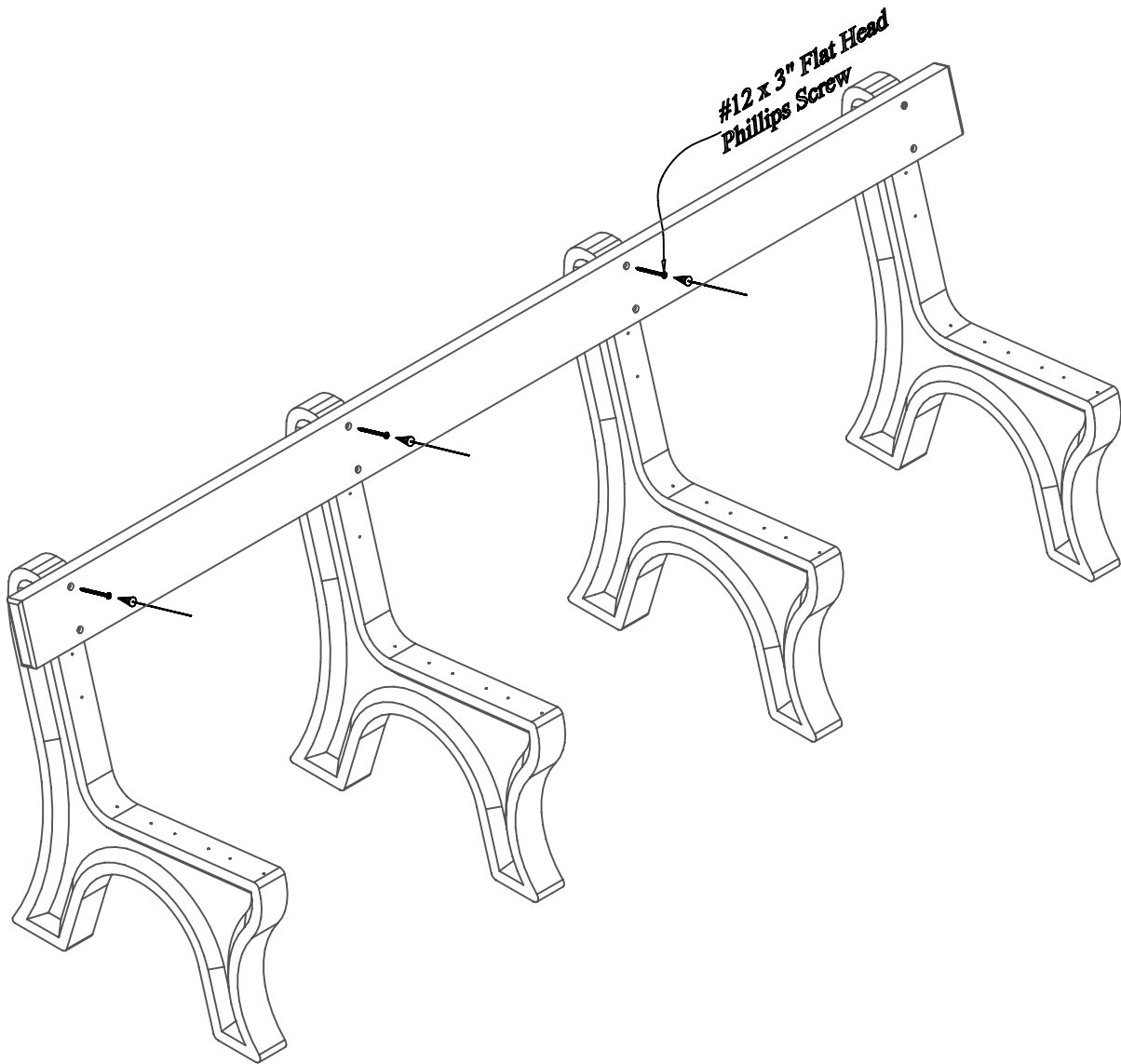

Step #2:

Stand the other (3) Three bench ends upright, one at a time, and place the bench board already attached to the first bench end, on position 1 being sure to align the pre-drilled holes to the pilot holes in the bench end. After the holes are properly aligned, fasten with (1) One #12 x 3" Flat Head Phillips Screw in the top pre-drilled hole.

Note: Do not tighten screws completely. This will be done in a later step.

Step #3:

Align bottom pre-drilled holes to the pilot holes in the bench end. After the holes are properly aligned, fasten with (1) One #12 x 3" Flat Head Phillips Screw per hole.

Note: Be sure to tighten screws completely after this step.

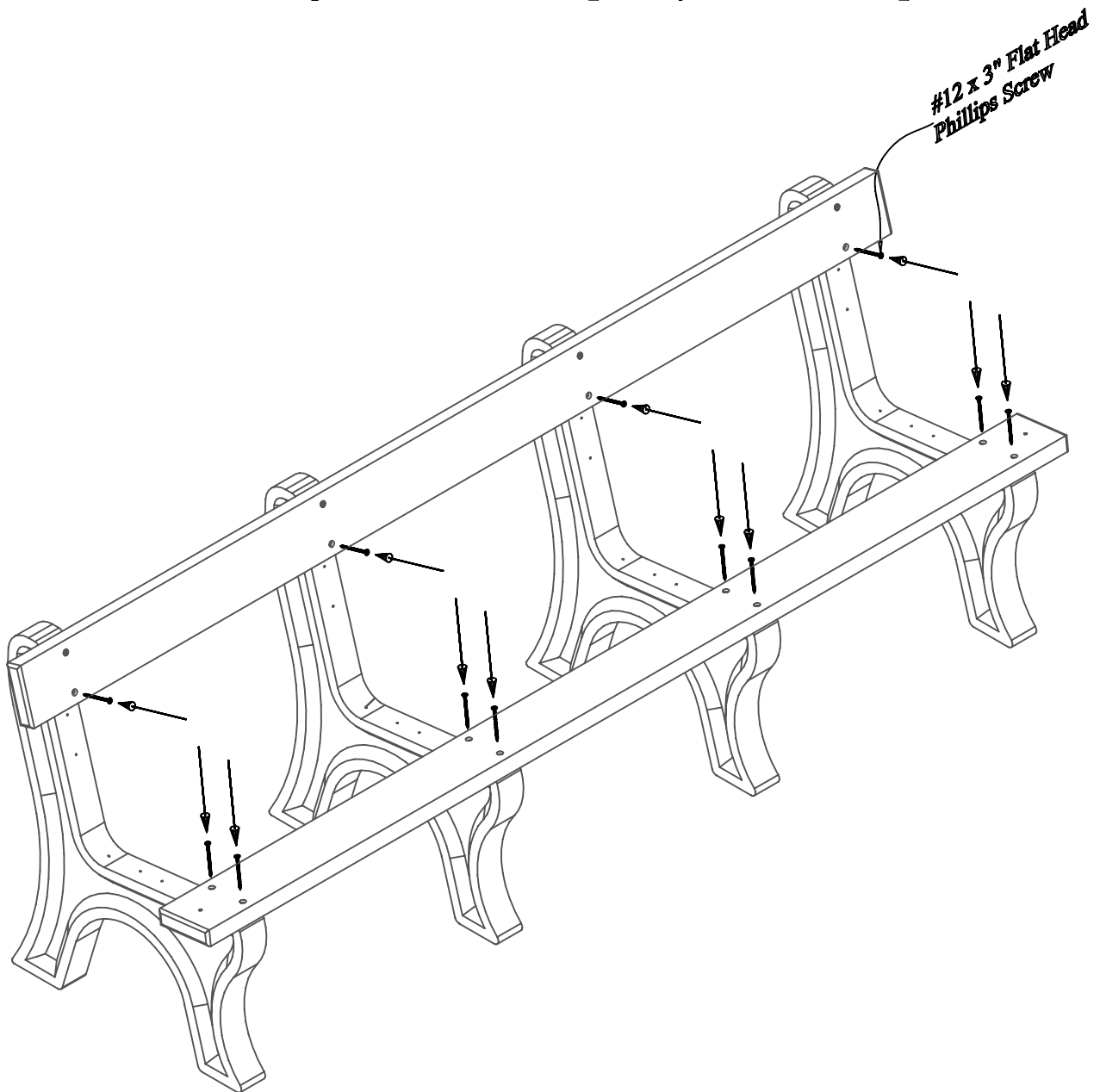

Step #4:

Place a bench board w/ arm holes on position 5. Repeat Steps 1 - 3 to attach. Use (1) One #12 x 3" Flat Head Phillips Screw per hole to fasten.

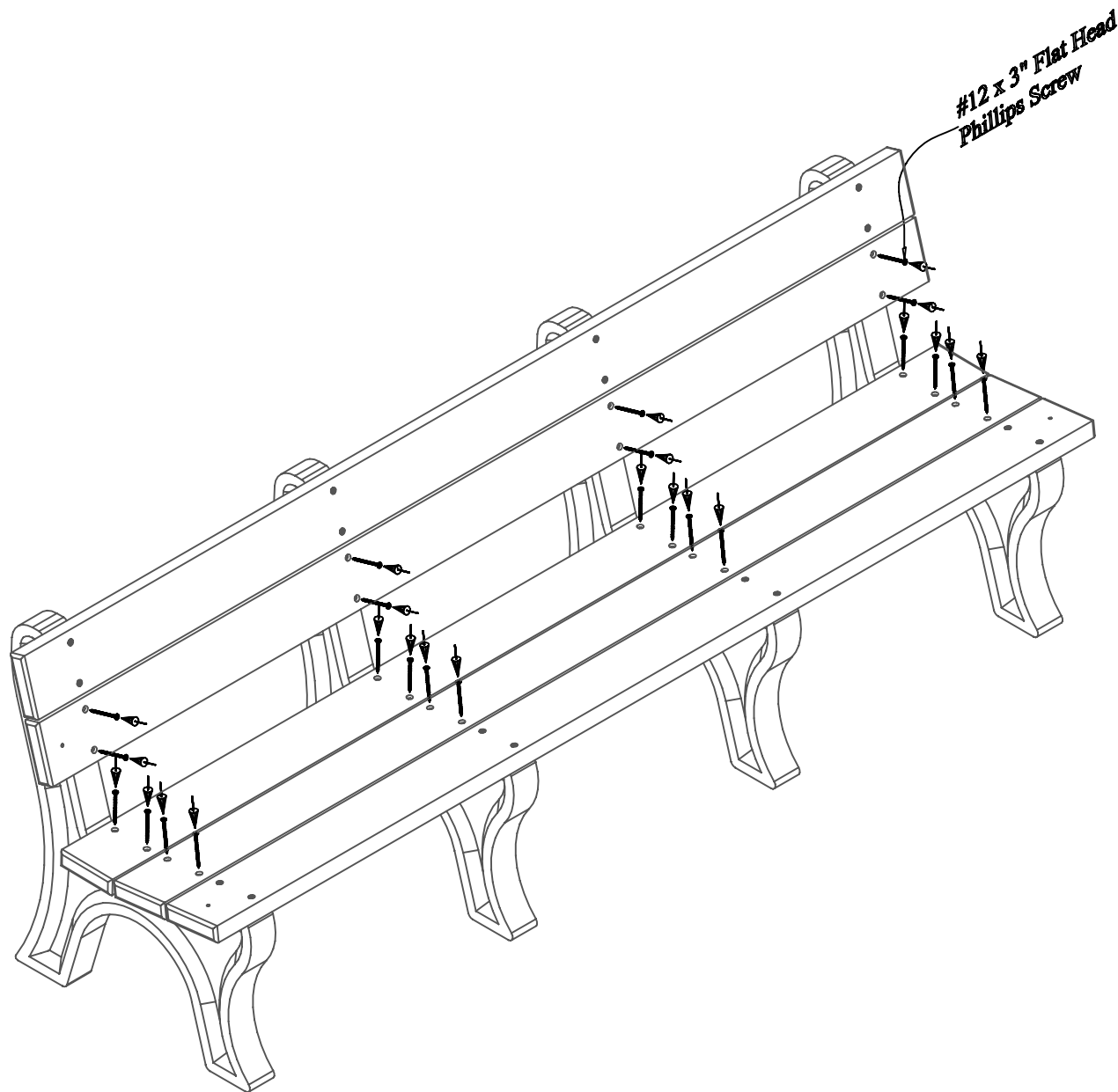

Step #5:

Repeat Steps 1 - 3 to attach bench board w/ Arm holes on position 2 and bench boards on positions 3 and 4 with (1) One #12 x 3" Flat Head Phillips Screw per hole to fasten.

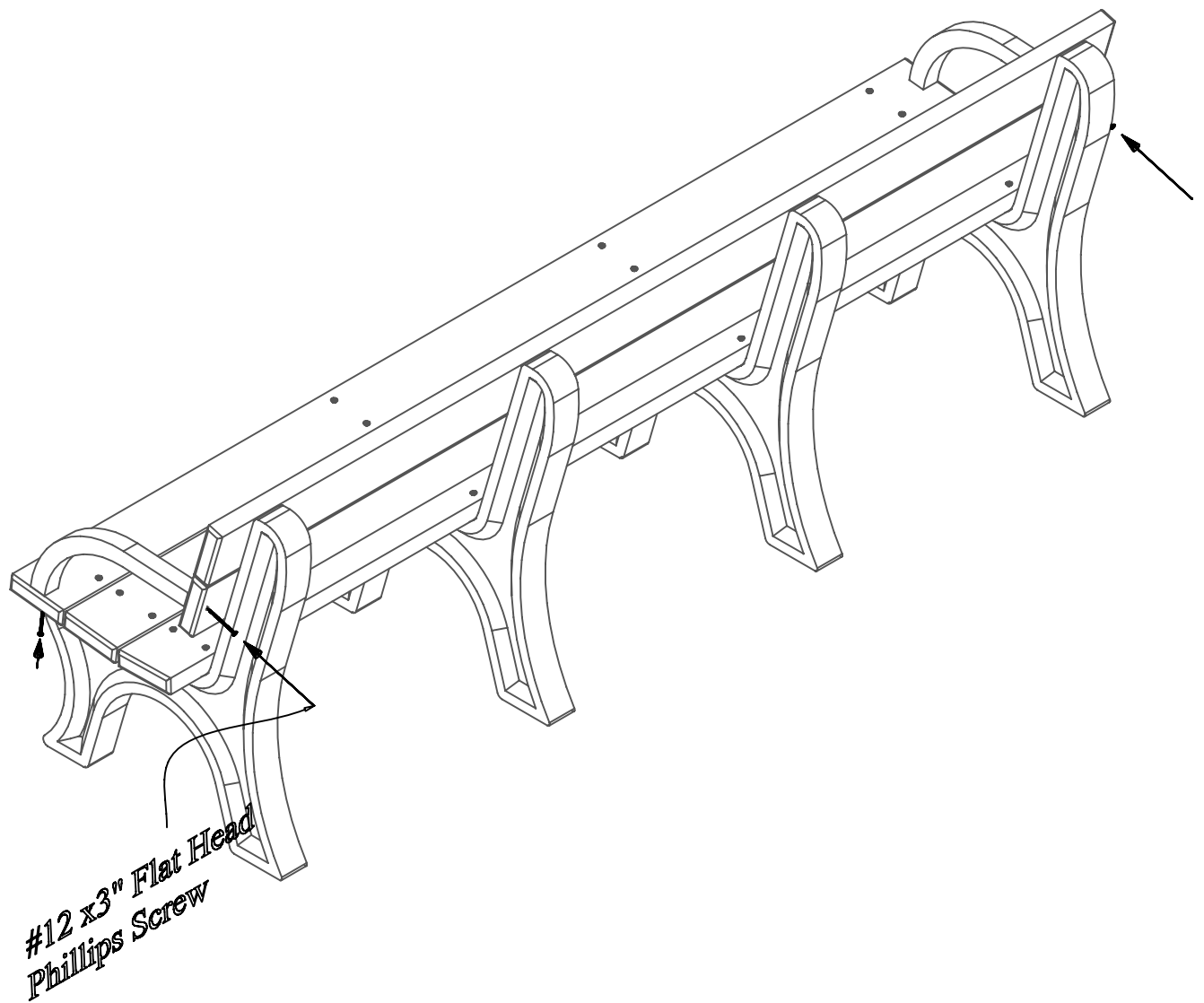

Step #6:

Position the bench arms as shown above. align the pilot holes to the pre-drilled holes in the bench board w/ arm holes. After the holes are properly aligned, Fasten (1) One #12 X3" Flat Head Phillips Screw per hole.