



Tools Needed for Installation

- Tape Measure
- Marker or Pencil
- Masonry Drill Bit
- Drill (Hammer drill recommended)
- Hammer
- Wrench 9/16"
- Level

Recommended Base Materials:

Solid concrete is the best base material for installation. To ensure the proper anchors are shipped with your rack, ask your Dero Rack representative which anchor is appropriate for your application. Be sure nothing is underneath the base material that could be damaged by drilling.

Installation:

3/8" anchors are shipped with the rack. Place the rack in the desired location. Use a marker or pencil to outline the holes of the flange onto the base material. Drill the holes in accordance with the specifications shipped with the anchors. Make sure the holes are at least 3" away from any cracks in the base material. Use washers to level rack if necessary. Tap in anchors and follow your specific anchor instructions provided with the rack.

Tamper Resistant Fasteners

The concrete spike is a permanent anchor. The top of the wedge anchor can also be pounded sideways after installation so that it cannot be removed. Other tamper resistant fasteners are also available for purchase.

When using the special tamper resistant nuts, always set and first tighten the anchors. Once the rack is installed, replace two nuts from the bracket (opposite sides from each other) with the tamper resistant fastener. DO NOT OVERTIGHTEN the tamper resistant nut.

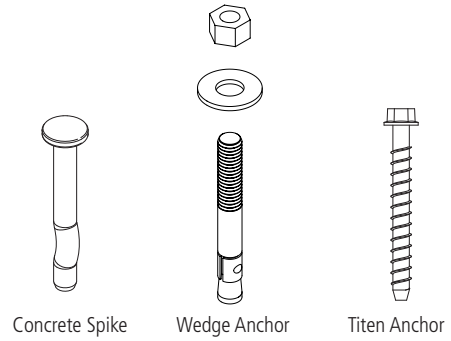

Standard Anchor Types

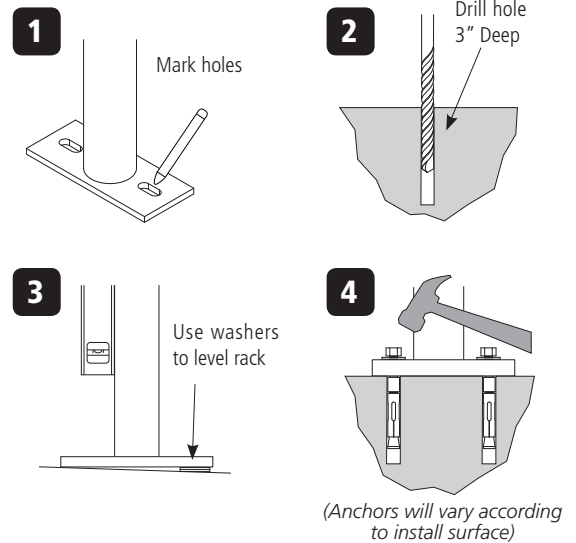



Tools Needed for Installation

Level	Hole coring machine with 4" bit
Cement mixing tub	Access to water hose
Shovel	Materials to build brace (see "Install Tip" at bottom of page)
Trowel	

Installing into Existing Sidewalk

Core holes no less than 3" diameter (4" recommended) and 10" deep into sidewalk. Fill holes with Por-Rok or epoxy grout. Place Hoop Rack into holes, making sure the rack is level. 33"-36" of the Hoop Rack should remain above the surface. If the Hoop Rack is less than 33" high, it will not support the bike adequately. Make sure the rack is level and held in place until the grout has set.

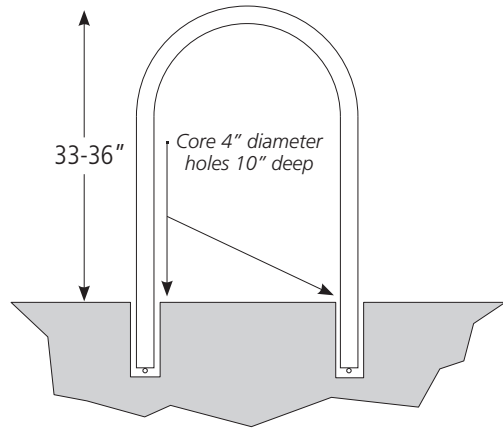

Installing Into a New Sidewalk:

Sleeve Method:

1 Place corrosion resistant sleeve (min. 4" inside diameter) in sand pour bed in exact location where rack will be installed. Make sure top of sleeve is at same level as desired finished concrete surface. Fill sleeve with sand to keep it in place and prevent it from filling with concrete.

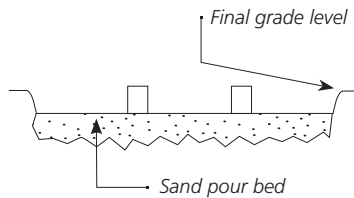

2 Pour concrete and allow to cure.

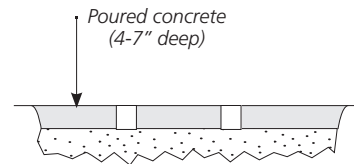

3 After appropriate cure time, dig out sand from sleeves and insert racks, making sure they are level and at the appropriate height. Pour in Por-Rok or epoxy grout and allow to set.

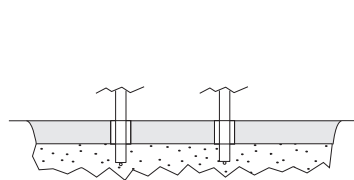

Note: Sleeve should have profile to keep it from coming loose from hardened concrete.

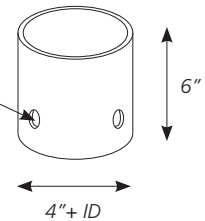

INSTALL TIP

An easy way to brace the Hoop Rack while the grout sets is to bolt two 1x4" boards together at one end and clamp them onto the legs of the Hoop Rack like a clothes pin.

