

#### INSTALLATION DETAILS

- Recommended crew (Adult): 2-3
- Installation time: 4-6 Hours not including concrete cure time
- User age: 5-12
- Use zone: 18' Diameter
- Weight: 300
- Actual Dimension: 67" Diameter

#### MAINTENANCE:

- As the owner of the playground you are responsible for maintenance of the equipment and play area. A maintenance schedule must be developed and the equipment inspected frequently. Periodic Inspections, maintenance, repair and replacement of damaged parts is necessary for the safe operation and use of the equipment
- A maintenance section that includes component specific maintenance requirements is included at the end of this document.

#### WARNING

**Use of safety surfacing (wood mulch) in compliance with ASTM specification F1292 is required.**



**UNIT IS DESIGNED FOR 12" OF LOOSE RESILIENT SURFACING. WOOD MULCH IS THE MANUFACTURERS PREFERRED MATERIAL.**

**THIS UNIT WILL NOT INSTALL ON POUR IN PLAY. UNIT WILL ALSO NOT INSTALL OVER ANY OTHER SURFACING THAT IS LESS THAN 12" HIGH**

**PARTS LIST**

ID	PART #	DESCRIPTION	QTY
1	913-321	67" Deck Assembly	1
2	913-323	Handrails	3
3	913-322	Post Assembly	1
4	126-701bps	3/8 x 1 1/4" Button Head Bolt	36
5	226-602	3/8" Nylon Lock Nut	36
6	336-029	1" Ball Bearing	1
7	416-505BPK	7/32" Socket Key	2
8		Handrail Touch-up Paint	1
9	316-601	3/8" Flat Washer	72

**NOTE:** Keep a copy of these instructions on file to assist you with maintenance and replacement parts.

**UNIT IS DESIGNED FOR 12" OF LOOSE RESILIENT SURFACING. WOOD MULCH IS THE MANUFACTURERS PREFERED MATERIAL AND THIS UNIT WILL NOT INSTALL ON POUR IN PLAY. UNIT WILL ALSO NOT INSTALL OVER ANY OTHER SURFACING THAT IS LESS THAN 12" HIGH**

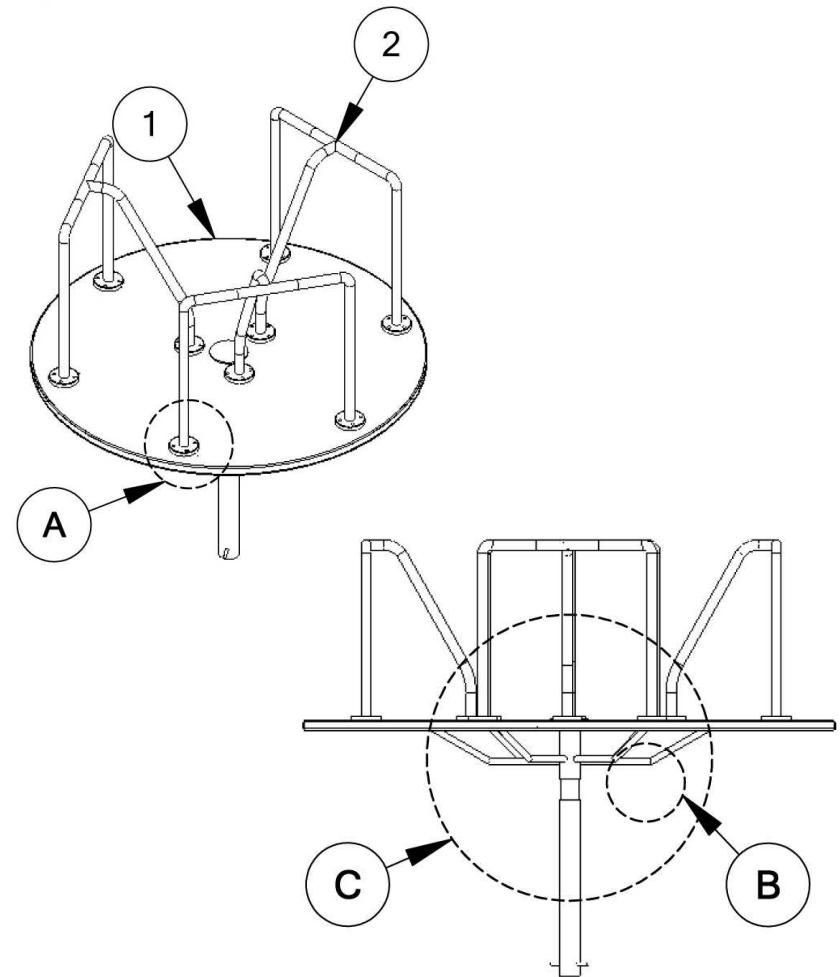

**301-142 6' MGR  
INSTALLATION INSTRUCTION**

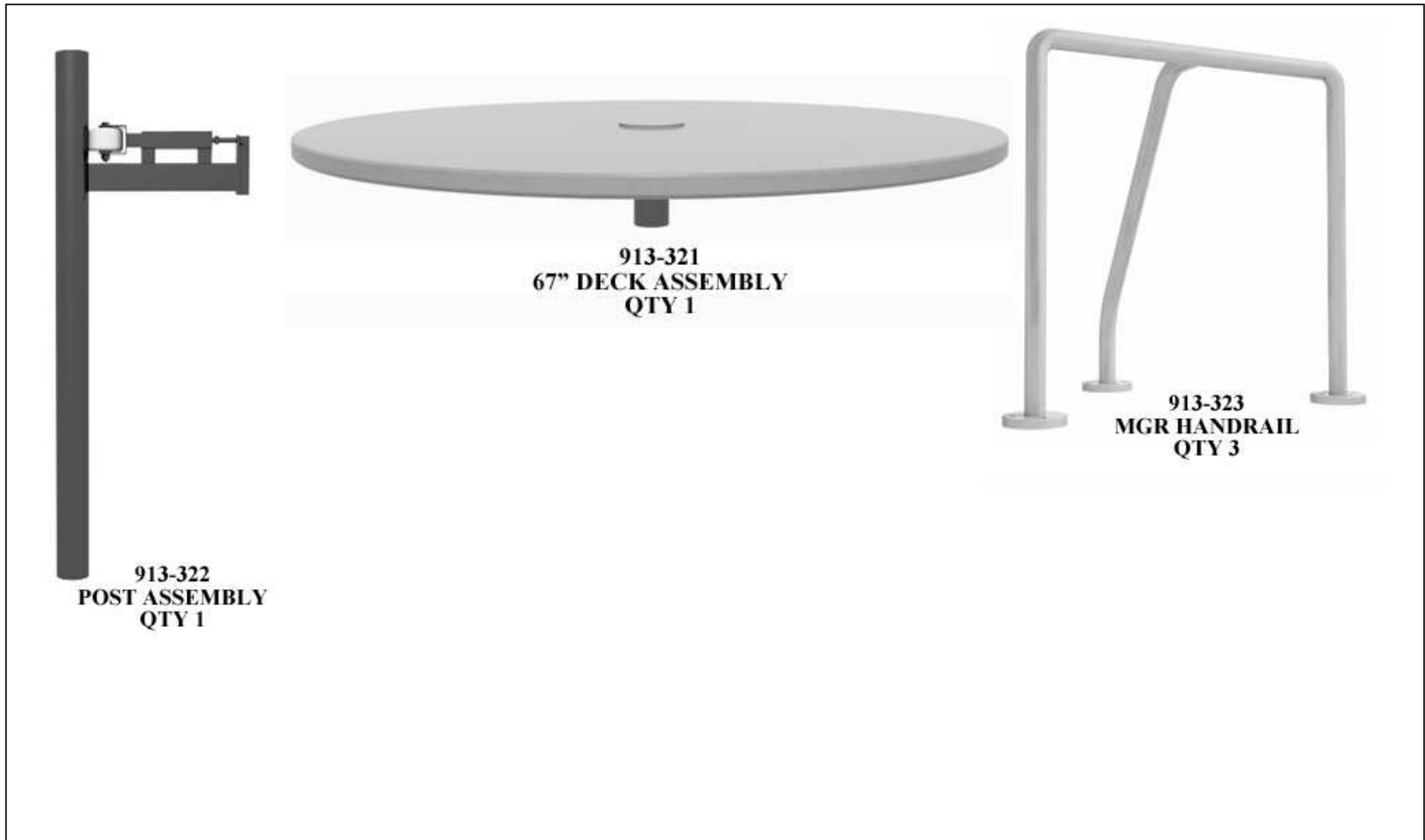

**FOOTING INFORMATION**

- Total footing depth is 24" plus the height of the surfacing which is 12". The 24" includes 8" of blocking material, which in this case is dry concrete. So overall only 16" of the post assembly is inserted into the footing hole. See drawing on next page for footing/surfacing reference
- It is the owner/installers responsibility to check local building codes and to comply with those codes. All footing depths listed here are recommendations and local soil types and frost lines may require a deeper and/or wider footing depth. If that's the case you must add more blocking material to accommodate the deeper footing, as the post length will still only be installed at the depth listed in this instruction manual.

**301-142 6' MGR  
INSTALLATION INSTRUCTION**

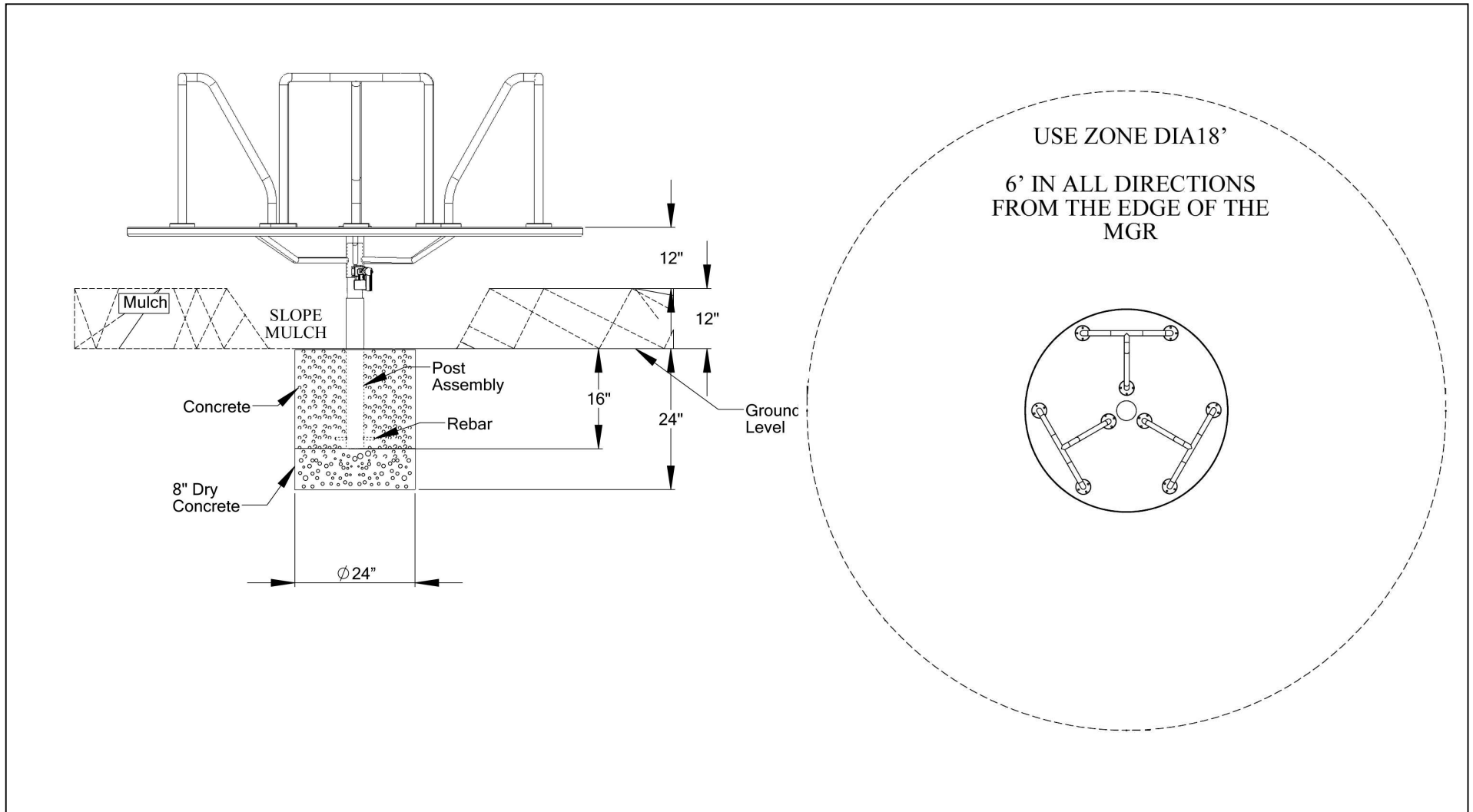

### SPECIFICATIONS

- Deck – One piece 11 gauge steel deck with rolled edge
- Deck Coating – Thermoplastic
- Handrail – 30” high 1 5/8” od FloCoat galvanized steel tube welded to a 3/8 flange
- Handrail Coating – Electrostatically applied and oven cured polyester powder coating
- Post Assembly – 2 1/2” OD solid steel shaft with machined pocket for bearing.

### SPECIAL SAFETY & ASTM COMPLIANCE NOTES

- 

### INSTALLATION TIPS & TROUBLE SHOOTING

- **12” of loose fill surfacing is required for this unit. The manufacturer recommends using a certified wood fiber/chips surfacing rather than sand or pea gravel because wood will hold its shape better and is less likely to cause damage by getting caught inside the mgr post like sand or gravel is likely to do.**
- Apply locktite to all bolts during assembly prior to completely tightening them.
- Stainless Steel hardware can occasionally be difficult to use particularly if you need to take them out to make an adjustment. It is recommended that you add a drop of oil to bolts that may have to be removed before you install them.
- Do not tighten bolts all the way until the unit is completely assembled and all components are square and level.
- Identify and separate all parts by referencing the detail drawings and the parts list.
- As you unpack and separate the components, use the cardboard sheets that were used for packing and shipping to prevent damage to the components. This is particularly true all Powder Coated and Thermoplastic coated components, by setting the components on top of the cardboard.

**BEFORE YOU BEGIN**

In addition to the components on the packing list you will need a shovel, concrete, magnetic level and a socket or wrench set.

**INSTALLATION STEPS**

\_\_1. Once the desired location has been determined while keeping safety fall zone in mind, dig a 24" diameter hole to a depth of 24" .

\_\_2. After hole is cleaned out of all loose material, fill the approximately 8" with dry concrete directly from the bag, this will serve as an extra footing base. Then place the 2.5" post assembly in the hole with the bearing pocket facing up.

**CAUTION:** The post assembly must be perfectly level in all directions before pouring concrete, then check periodically for the first hour after the initial pour to make sure it stays level.

\_\_3. Place the steel ball bearing into the bearing pocket on the post and lightly lubricate with multi purpose grease. You will need to lubricate the merry go round as needed to maintain proper spin and eliminate any possible post and shaft wear.

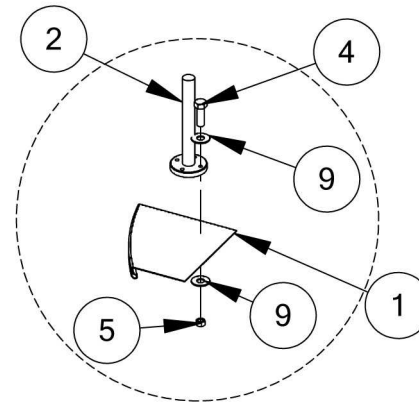

DETAIL A  
Typ 36 Pls

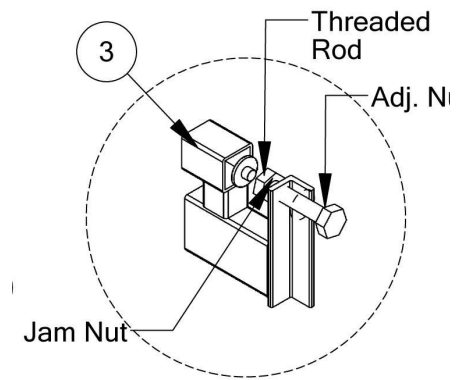

DETAIL B  
Tension  
Adjustment  
View

**INSTALLATION STEPS CONTINUED**

\_\_4. With the help of at least one other person slowly lower the deck assembly down onto the post assembly, use caution to make sure the bearing is not knocked out of the bearing pocket. **NOTE**; If the deck assembly seems to catch and doesn't go all the way down, it may be necessary to unscrew the grease fitting slightly as this will sometimes hit the post assembly and cause this problem. (detail C)

\_\_5. Now place the 3 handrails on the deck assembly and attach using bolts, washers and nuts. (detail A) **NOTE**: You may need to pull/stretch the handrails in order to get them to line up, but this is normal as the welding process will cause them to draw/shrink together slightly.

\_\_6. Tension Adjustment: Begin by backing off jamb nut then tighten the adjustment bolt until the rubber wheel is pushing firmly onto the sleeve on the bottom of the deck assembly.

\_\_7. Finally install the safety surfacing (refer to the drawing on page 5) around the unit. 12" of loose fill surfacing is required. You may slope the surfacing under the deck down to allow access to the governor and grease fitting. Be sure to grease the unit prior to use and periodically as the maintenance guide suggests.

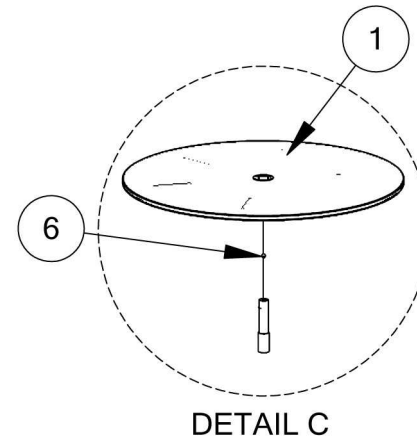

DETAIL C



### Operational

- Grease Merry Go Round Weekly or daily in an environment that has sand or other small damaging materials.

### Hardware

- Inspect for loose or missing hardware. Tighten all loose hardware and replace all missing hardware. Block off access to equipment if necessary.

### Welds

- Inspect all welds for cracks. If a crack is found block access to the playground and contact your distributor for replacement parts immediately.

### Governor

- Inspect Governor weekly when greasing unit. Ensure that all pieces are installed and secure
- Ensure rubber wheel is in contact with the sleeve. If not, tighten by first backing off jam nut, tighten adjustment bolt until wheel is in position and then tighten the jam nut.

### Finish

- Inspect all metal components for coating damage. If powder coating needs to be repaired sand surface and mask off area. Coat with primer and once the primer has dried paint with color matching touch up paint. Contact distributor of color matching paint. Contact Distributor for Thermoplastic repair kit.

**Surfacing** - Refer to the surfacing maintenance sheet provided by your surfacing supplier.

### Footings

- Inspect all footings to ensure equipment is secure. You must block access to prevent access until repair is made.

### Replacement Parts

- Reference the parts list on page 2 of the instruction set for this component to identify the part/s correctly.
- Contact your distributor to order parts.



**INSPECTION FORM**

- MAKE COPIES OF THIS FORM TO USE FOR INSPECTION
- REVIEW THE “MAINTENANCE GUIDE” IN THE APPENDIX TO BETTER UNDERSTAND THE IMPORTANCE OF MAINTENANCE AND HOW TO DEVELOP A MAINTENANCE SCHEDULE.
- DOCUMENT ALL MAINTENANCE ACTIONS ON THE LIST AS WELL AS ANY NOT LISTED.
- INCLUDE DATES AND SIGNATURES

Inspection Checklist	Recommended Frequency	Grade (Pass/Fail/NA)	Date Inspected	Date Repairs Completed
Inspect Govenor	Weekly			
Inspect Hardware	Weekly			
Grease Shaft	Weekly			
Inspect Finish	Monthly			
Inspect Footing	Yearly			
Inspect Surfacing	Daily			

Inspector: \_\_\_\_\_ Signature: \_\_\_\_\_ Date: \_\_\_\_\_

<b>Maintenance Record</b>			
Part	Problem	Corrective Action	Date