

# 111-201 PLAY HOUSE

## IMPORTANT

PLEASE READ THESE INSTRUCTIONS BEFORE COMMENCING ASSEMBLY. All equipment must be installed in accordance with these instructions. Check your shipment against Bill of Lading and Parts list. Any missing or broken parts must be reported to your distributor within 10 days of receipt of your order. When properly installed and maintained, equipment will give many years of Safe, Trouble-Free use. Periodically check for loose or broken parts. Loose bolts must be tightened and broken parts must be replaced as they can possibly create dangerous situations leading to unnecessary accidents. Resilient Surfacing should be used under all playground equipment. Retain a copy of these instructions for maintenance and replacement part purposes

Appropriate publications, available at no charge, from the Consumer Product Safety Commission, include "A Handbook for Public Playground Safety". You can receive your free copy by calling 1-301-504-7908 or at [www.cpsc.gov](http://www.cpsc.gov). You can get a copy of the ASTM standards for Play Equipment and Safety surfacing at [www.astm.org](http://www.astm.org)

**Safety Surfacing - Use of safety surfacing in compliance with ASTM specification F1292 is required. Contact your surfacing supplier for required surfacing depth for this equipment.**

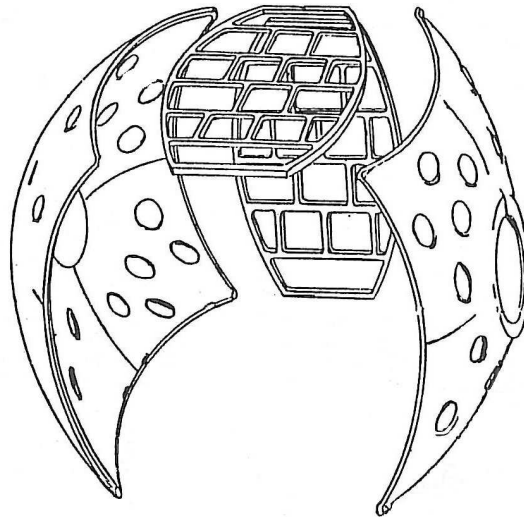

### PACKING LIST

1	CTN	1	Hardware Bag
		8	503-637 Anchor
1	CTN	2	103-038A Grille
1	SKID	2	113-044 Shell

### HARDWARE BAG

12	116-530	5/16" x 1" Button Head Bolt
16	116-540	5/16" x 2" Button Head Bolt
28	326-501	5/16" Lock Washer
52	316-601	3/8" Flat Washer
28	216-512	5/16" Button Head Nut
2	105-210	Angle Bracket
2	416-350	3/16" Socket Key
2	805-532	Warning Label
2	805-534	MFG Label

2 CTN

1 SKID

3 TOTAL PCS

Weight 400#

Class 70

# 111-201 PLAY HOUSE

## DETAILS

<b>Equipment Dimension</b>	60"L x 60"H X 69"W	
<b>Use Zone</b>	17' X 17'9"	
<b>User Age</b>	2-12	
<b>Number of Users</b>	10	
<b>Minimum Recommended Number of People for Installation</b>	2	
<b>Installation Time/Total Man Hours</b>	2/4	Does not include concrete cure time

## MATERIAL SPECIFICATIONS

<b>Anchor</b>	1" O.D. 15ga Flo-Coat galvanized tube	<b>Hardware</b>	Stainless Steel
<b>Grille</b>	Permanent mold cast using #319 aluminum alloy	<b>Coating</b>	Thermoplastic coating
<b>Shell</b>	Permanent mold cast using #319 aluminum alloy		

**GENERAL FOOTING RECOMMENDATIONS**

Diameter and depth of footings illustrated are satisfactory in most applications for pipe sizes up to 2 3/8" diameter. Varying soil & climatic conditions may require deeper and heavier footings in some areas. Check local building codes.

Diagram:  
Permanent Installation

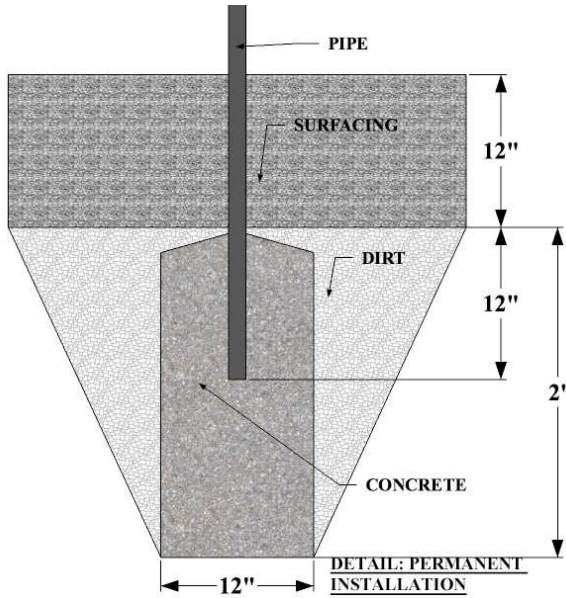
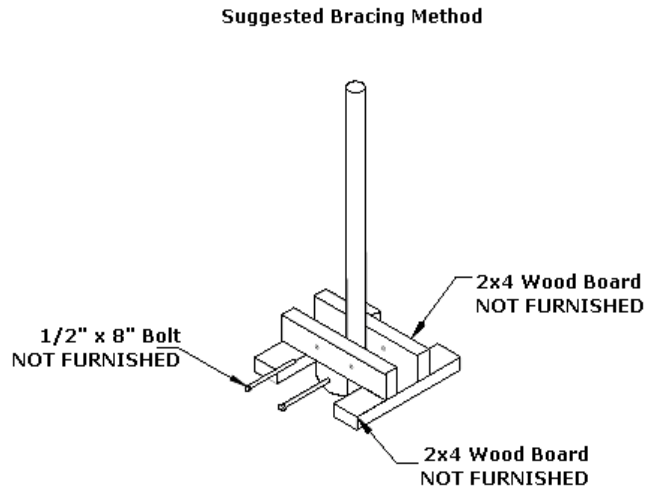

Diagram:  
Suggested Bracing Method



**Footing**

Total footing depth is 36" including the surfacing (of that 36" only 24" of anchor will be put in footing hole. The remaining 12" will be nothing but concrete). SportsPlay Equipment manufactures all equipment to include 12" of safety surfacing. If using 12" of surfacing will need to dig your hole 24" deep. If using less than 12" of surfacing your footing depth will need to be deeper (6" of surfacing you would need to dig your hole 30" deep).

# 111-201 PLAY HOUSE

Page 4  
Rev. 05/21/2010

## USE AREA AND FOOTING LAYOUT:

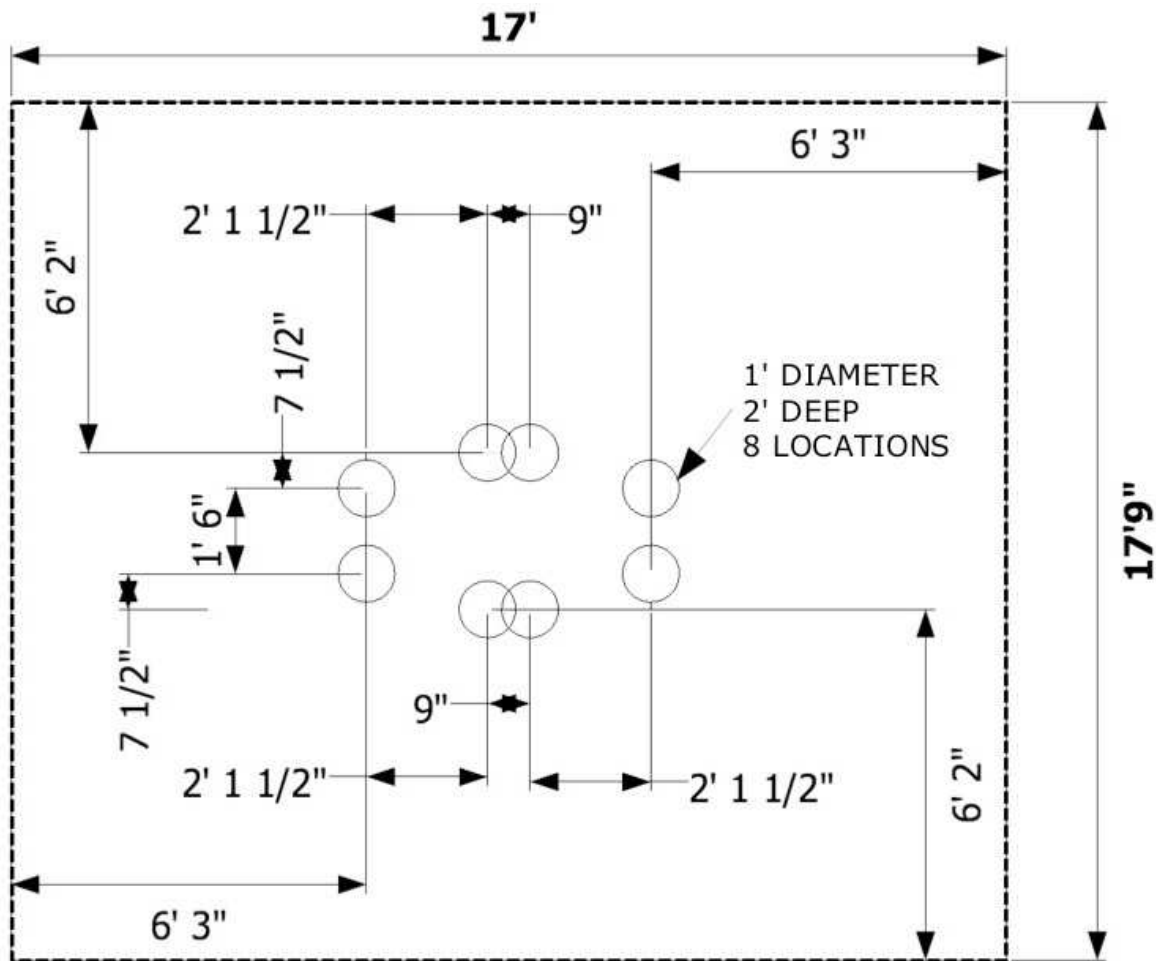

## GENERAL USE/FALL ZONE RECOMMENDATIONS:

The fall zone extends 6' in all directions.

## GENERAL MAINTENANCE INSTRUCTIONS:

Check MONTHLY for loose bolts, damaged or broken parts. Tighten and/or replace immediately. Replace any parts that show a reduction of 25% from the original size. Inspect all labels for damage and replace if necessary. Contact your distributor and reference the part numbers on this instruction set for replacement parts.

Inspect coating for damage. Contact your distributor for a Thermoplastic touch up kit if necessary.

# 111-201 PLAY HOUSE

Page 5

Rev. 05/21/2010

## ASSEMBLY AND INSTALLATION:

**NOTE:** All threaded ends of bolts protruding beyond nuts must be cut off and/or peened to eliminate sharp edges. No more than two threads should extend beyond face of nut. All washers, "T" nuts and other fastener hardware used on round pipe or tubing must be hammered down to conform to the curved underlying surface to eliminate catch points. DO NOT tighten nuts more than hand-tight until entire assembly is completed.

- STEP 1** Mark footing holes per layout drawing on page 4. Dig the holes per the footing drawing on page 3. (8 holes 2' deep)
- STEP 2** Start with one shell upside down and attach the two grilles by inserting a 5/16" nut through a 3/8" washer and into the grille. Then insert a 5/16" x 2" bolt through a 5/16" lock washer the shell, grille and into the 5/16" nut. Then move the shell into the proper position over the footing holes. (see drawing on page 1 and below for help with this step).

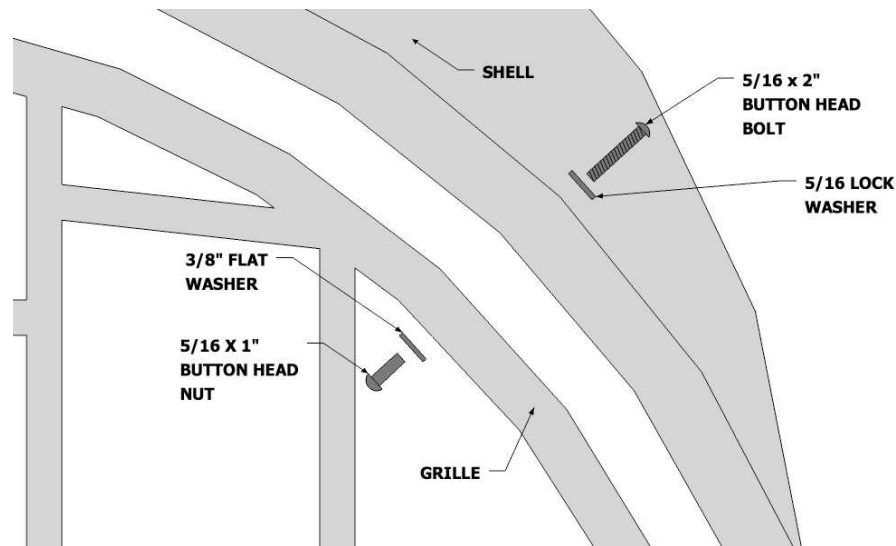

- STEP 3** Attach second shell following the procedure in step 2. Then attach the Angle bracket where the two Grilles meet with the 1" bolt, lock washer, flat washer and button head nut.

## 111-201 PLAY HOUSE

Page 6

Rev. 05/21/2010

- STEP 4** Attach anchor posts to shells by inserting a 5/16 x 1" bolt through a 3/8" washer, the shell, then anchor, 3/8" washer and into a 5/16" button head nut (see drawing below).

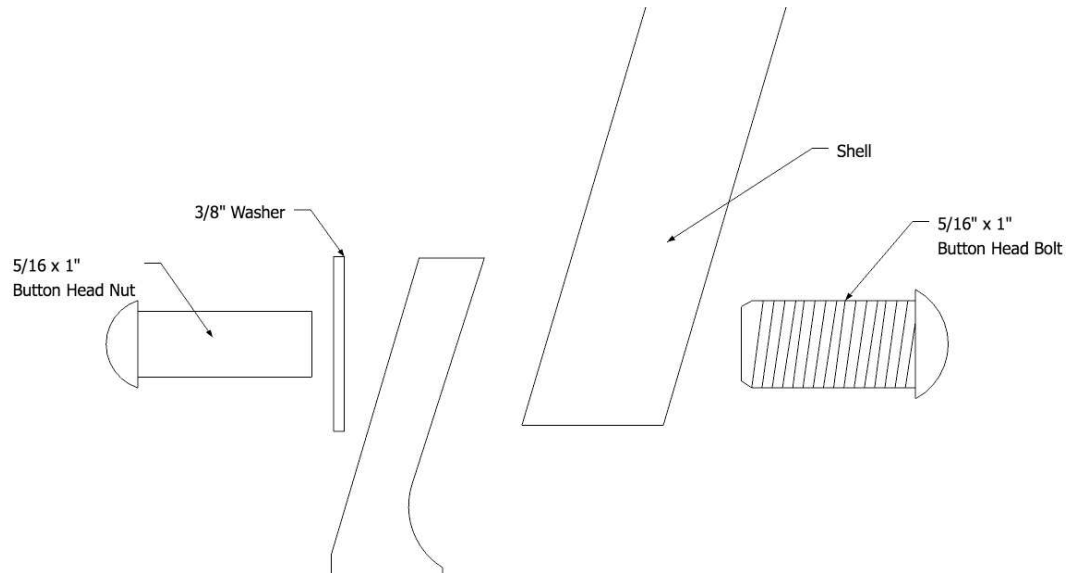

- STEP 5** Block and Brace the entire unit up to accommodate 12" of surfacing (this unit is manufactured for 12" of surfacing. See footing note on page 3 if you are not using 12" of surfacing).
- STEP 6** Plumb and level the entire unit. Tighten all nuts and bolts so that the lock washers (if used) are flat and all regular hardware is tight. Pour concrete and let set minimum of 48 hours or longer if the concrete manufacturer requires it. After concrete has set, remove bracing and backfill holes. Install surfacing in the entire fall zone per your surfacing suppliers guidelines.
- STEP 7** Attach warning label and manufacturer's identification label to a clean surface. Labels should be attached in a location where they are clearly visible and legible and away from normal hand and foot placement.