

361-505 Teeter Spring Rider

Page 1
Rev. 01/25/2011

IMPORTANT

PLEASE READ THESE INSTRUCTIONS BEFORE COMMENCING ASSEMBLY. All equipment must be installed in accordance with these instructions. Check your shipment against Bill of Lading and Parts list. Any missing or broken parts must be reported to your distributor within 10 days of receipt of your order. When properly installed and maintained, equipment will give many years of Safe, Trouble-Free use. Periodically check for loose or broken parts. Loose bolts must be tightened and broken parts must be replaced as they can possibly create dangerous situations leading to unnecessary accidents. Resilient Surfacing should be used under all playground equipment. Appropriate publications, available at no charge, from the Consumer Product Safety Commission, include "A Handbook for Public Playground Safety". You can receive your free copy by calling 1-301-504-7908.

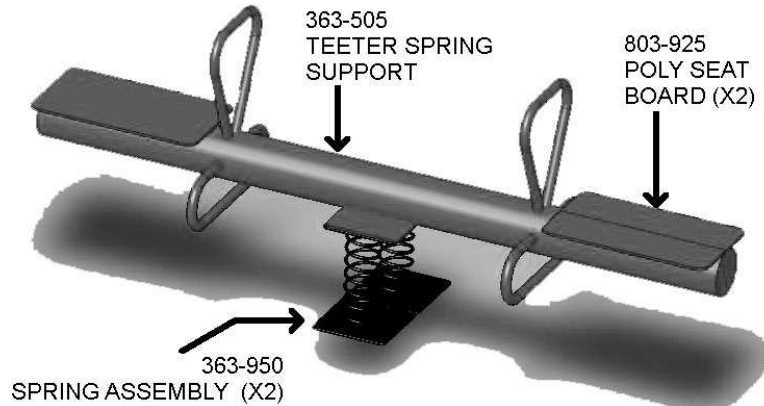

<u>PACKING LIST</u>			<u>HARDWARE BAG</u>		
CTN	1	Hardware Bag	8	126-703	3/8" x 1" BH bolt
	2	803-925 Poly Seat Board	8	116-535	5/16" x 1 3/4" BH bolt
	1	363-505 Teeter Spring Support	8	196-644	3/8" x 8" Anchor bolt
	2	363-950 Spring Assembly	8	216-601	3/8" Hex Nut
			8	226-502	5/16" Nylon Insert Lock Nut
			16	226-602	3/8" Nylon Insert Lock Nut
			8	316-501	5/16" Flat Washer
			40	316-601	3/8" Flat Washer
			1	416-505	7/32" Long arm socket key
			1	416-350	3/16" Socket Key
			1	805-532	Warning Label
			1	805-534	SportsPlay Label
			1		Maintenance Checklist

1 Carton

230 # Weight

Class 70

361-505 Teeter Spring Rider

Page 2
Rev. 01/25/2011

GENERAL USE/FALL ZONE & FOOTING RECOMMENDATIONS:

Stationary & Portable equipment - Use/Fall zones should extend a minimum of 6 feet in all directions from the perimeter of the equipment ground space. This area should be covered with the required amount of resilient safety surfacing material.

For some equipment - Use/Fall zones can overlap. See Consumer Product Safety Commission Guidelines. Diameter and depth of footings illustrated are satisfactory in most applications for pipe sizes up to 2 3/8" diameter. Varying soil & climatic conditions may require deeper and heavier footings in some areas. Check local building codes.

IF RESILIENT SURFACING IS TO BE LESS THAN 12", THEN ADDITIONAL PIPE SHOULD BE PUT IN CONCRETE TO MAINTAIN PROPER FINISH GRADE FOR EQUIPMENT.

USE AREA AND FOOTING LAYOUT:

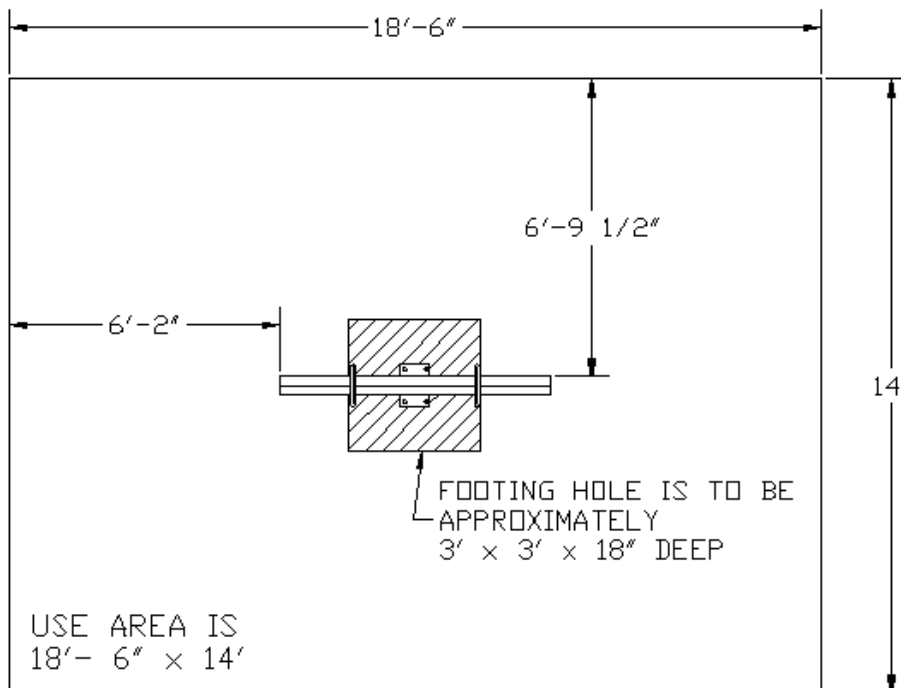

GENERAL MAINTENANCE INSTRUCTIONS:

Check MONTHLY for loose bolts, damaged or broken parts. Tighten and/or replace immediately. On swings and any equipment that uses S-hooks and/or Swing Hangers check the bearing surfaces for wear. Replace any parts that show a reduction of 25% from the original size.

361-505 Teeter Spring Rider

Page 3
Rev. 01/25/2011

ASSEMBLY AND INSTALLATION:

NOTE: All threaded ends of bolts protruding beyond nuts must be cut off and/or peened to eliminate sharp edges. No more than two threads should extend beyond face of nut. All washers, "T" nuts, and other fastener hardware used on round pipe or tubing must be hammered down to conform to the curved underlying surface to eliminate catch points. DO NOT tighten nuts more than hand-tight until entire assembly is completed.

STEP #1: Dig footing hole approximately 3' x 3' x 18" deep. Before the concrete sets, assemble the anchor bolts to both bottom plates of the springs using a 3/8" hex nut, 3/8" washer and 3/8" lock nut.

STEP #2: Push both down into the wet concrete until both plates touch one another squarely and are level with the top of the concrete. See drawing on page 1 for orientation of springs and teeter - make sure you align the spring plates properly.

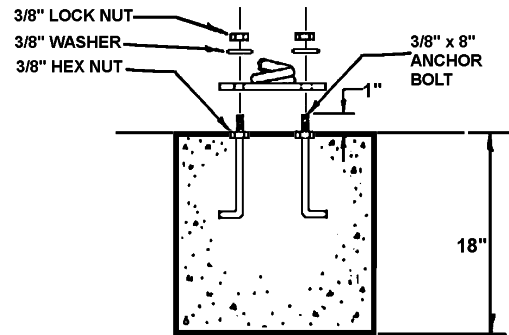

STEP #3: After concrete hardens for at least 48 hours, assemble the teeter rider seats to the rider by pushing 5/16" Button Head Bolts through the seats and pipe from above. Fasten from bottom using 5/16" Washer and Lock Nut. Tighten Securely.

STEP #4: Bolt the springs to the anchor bolts. Tighten Securely.

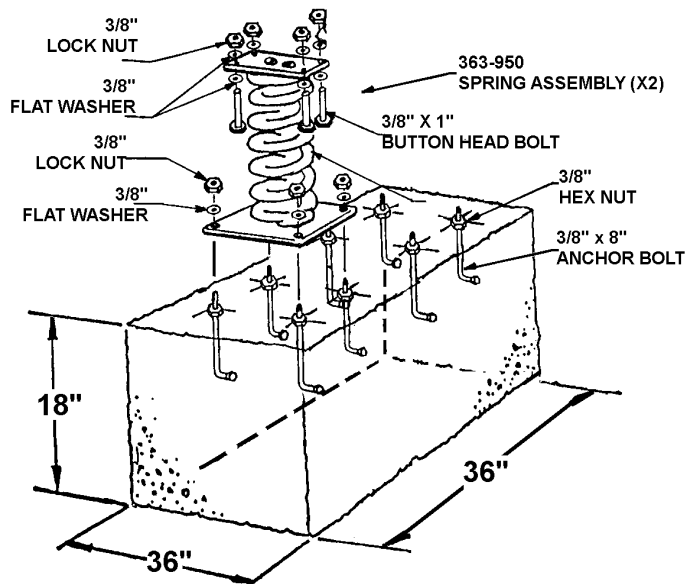

361-505 Teeter Spring Rider

Page 4

Rev. 01/25/2011

- STEP #4: Bolt the teeter rider to the upper spring plate using 3/8" x 1" Button Head Bolts, Washers and Lock Nuts. Tighten Securely.
- STEP #5: Install resilient surfacing according to manufacturer's instructions.
- STEP #6: After equipment has been in use at least three or four days, check and tighten all nuts and bolts.
- STEP #7: Attach warning label and Manufacturer's Identification label to a clean surface. The labels should be attached in a location where they are clearly visible and legible and away from normal hand and foot placement areas. The labels must be replaced if they become illegible, destroyed or removed. Contact your SportsPlay distributor for replacements.